

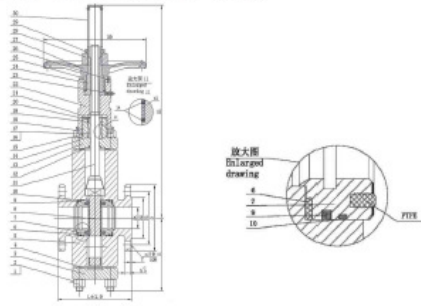

抗硫平板闸阀150#压力级按API 6D、NACE MR0175/ISO15156、API 6FA设计与制造
SULFUR RESISTANT SLAB GATE VALVE ANSI CLASS 150# as per API 6D, NACE MR0175/ISO15156 and API 6FA
口径2" -12" 明杆 OS & Y In size 2" -12"
• 口径≥10" (DN≥250) 闸门用轴承 Bearing is used for NPS≥10" (DN≥250)



主要阀门零件材料
STANDARD MATERIAL SPECIFICATIONS OF MAIN VALVE PARTS

零件名称/Part name	碳钢系列 Carbon steel series		不锈钢系列 Stainless steel series			
5 阀体 Body	A350 LF2	A 352 LCB	A 351 CF8	A 182 F304	A 351 CF8M	A 182 F316
13 阀盖 Bonnet	A 350 LF2*	A 352 LCB*	A 351 CF8	A 182 F304	A 351 CF8M	A 182 F316
1/16 螺柱 Studs	A193 B7M/A320 L7M		A193 B8M			
2/17 螺母 Bolts	A194 2HM/7M		A194 8M			
3 底座 Bottom	A350 LF2	A 352 LCB	A 351 CF8	A 182 F304	A 351 CF8M	A 182 F316
4/12 垫片 Gasket	复合垫片 Tanged gasket					
6/10 O型圈 O-ring	Kalrez(R)/FKM/HNBR**					
7 阀座 Seal ring	A350 LF2+STL+ENP+PTFE	A 182 F304+STL+ENP+PTFE	A 182 F316+STL+ENP+PTFE			
8 闸板 Gate	A350 LF2+STL	A 182 F304+STL	A 182 F316+STL			
9 填料 Packing	预成型柔性石墨环 Preformed flexible graphite rings					
11 阀杆 Stem	A 276 T316/Inconel 718					
14 填料 Packing	底部和顶部各一圈不锈钢丝加强的石墨编织填料 A ring of braided graphite reinforced with stainless steel wire at the bottom and top respectively					
15 填料 Packing	预成型柔性石墨环 Preformed flexible graphite rings					
20 填料压盖 Gland	A 276 T316					
22 支架 Yoke	A 105	A 182 F304		A 182 F316		
24 阀杆螺母 Stem nut	铝青铜或奥氏体球墨铸铁 D2 Aluminum bronze or D2					
27 手轮 Handwheel	WCB					

* 密封面堆焊316L, 316L is deposited on a backseat.
** 按用户要求, On user's request.

夹面端法兰按ANSI B 16.5; 对焊端口径按ANSI B 16.25; RTJ端法兰按ANSI B 16.5.
RF flange ends to ANSI B 16.5; BW ends to ANSI B 16.25; RTJ flange ends to ANSI B 16.5.

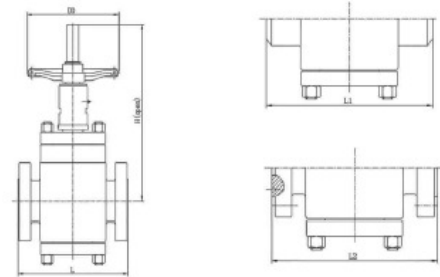

压力级150#平板闸阀之尺寸和重量 DIMENSIONS and WEIGHTS of 150# Slab Gate V

NPS	2	3	4	6	8	10	12
L (RF)	178	203	229	267	292	330	356
L1 (BW)	216	282	305	403	419	457	502
L2 (RTJ)	191	216	242	280	305	343	369
Hopen	480	570	625	773	955	1180	1375
D0	250	300	300	350	350	400	450
Kg (RF)	52	82	110	152	165	258	342
Kg (BW)	48	77	99	140	152	234	320

按API 6D试验压力 TEST PRESSURE to API 6D

阀体材料 Body material	强度试验 (MPa) Hydrostatic shell test ≥	水密封试验 (MPa) Hydrostatic seat test ≥	阀头水密封试验 (MPa) Hydrostatic back seat test ≥	气密封试验 (MPa) Air closure test ≥
A350 LF2	2.94		2.16	
A 352 LCB	2.76		2.02	
CF8/F304				0.4
CF8M/F316	2.85		2.09	

平板闸阀特点:

开启和关闭扭矩小。
全通径, 流体阻力, 流阻清晰可能。
碳钢成分中硫和磷含量比规定低, 利于抗硫化应力腐蚀和抗氢致裂纹。
O型圈可用Kalrez®材料, 适合含高H₂S的石油与天然气, 并抗高压爆裂破坏。

The features of Slab Gate Valves:

Opening & closing torque are small.
The full bores make the flow resistance small and pig possible.
S and P content are lower than those specified which are beneficial to SSC-resistant and HIC-resistant.
O-rings can be made of Kalrez®, suitable to oil crude and natural gas containing high H₂S content and RGD-resistant.



抗硫平板闸阀300#压力级按API 6D、NACE MR0175/ISO15156、API 6FA设计与制造
SULFUR RESISTANT SLAB GATE VALVE ANSI CLASS 300# as per API 6D, NACE MR0175/ISO15156 and API 6FA
口径2" -12" 明杆 OS & Y In size 2" -12"
• 口径≥8" (DN≥200) 闸门用轴承 Bearing is used for NPS≥8" (DN≥200)

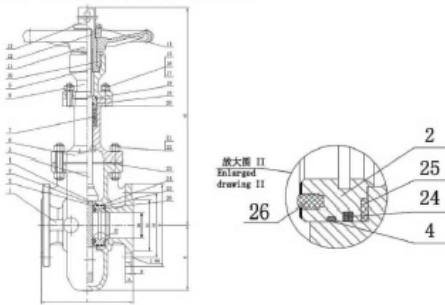

主要阀门零件材料
STANDARD MATERIAL SPECIFICATIONS OF MAIN VALVE PARTS

零件名称/Part name	碳钢系列 Carbon steel series		不锈钢系列 Stainless steel series			
1 阀体 Body	A350 LF2	A 352 LCB	A 351 CF8	A 182 F304	A 351 CF8M	A 182 F316
2 阀座 Seat ring	A350 LF2+STL+ENP+PTFE	A 182 F304+STL+ENP+PTFE	A 182 F316+STL+ENP+PTFE			
3 闸板 Gate	A350 LF2+STL	A 182 F304+STL	A 182 F316+STL			
4/25 O型圈 O-ring	Kalrez(R)/FKM/HNBR**					
5 阀杆 Stem	A 276 T316/Inconel 718					
6 阀盖 Bonnet	A350 LF2*	A 352 LCB*	A 351 CF8	A 182 F304	A 351 CF8M	A 182 F316
7 填料 Packing	PTFE					
8 支架 Yoke	A 105		A 182 F304		A 182 F316	
9 阀杆螺母 Stem nut	铝青铜或奥氏体球墨铸铁 D2 Aluminum bronze or D2					
11 手轮 Handwheel	WCB					
13 阀杆指示器 Stem Indicator	CS+PC					
20 填料压盖 Gland	A 276 T316					
21 螺柱 Studs	A193 B7M/A320 L7M		A193 B8M			
22 螺母 Nuts	A194 2HM/7M		A194 8M			
23 垫片 Gasket	缠绕式垫片 Spiral wound gasket					
24 填料 Packing	PTFE					

* 密封面堆焊316L, 316L is deposited on a backseat.
** 按用户要求, On user's request.

夹面端法兰按ANSI B 16.5; 对焊端口径按ANSI B 16.25; RTJ端法兰按ANSI B 16.5.
RF flange ends to ANSI B 16.5; BW ends to ANSI B 16.25; RTJ flange ends to ANSI B 16.5.

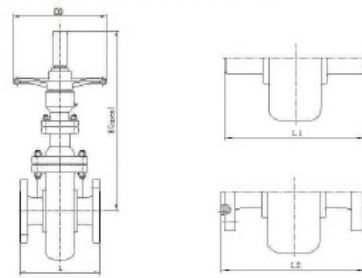

压力级300#平板闸阀之尺寸和重量 DIMENSIONS and WEIGHTS of 300# Slab Gate V

NPS	2	3	4	6	8	10	12
L (RF)	216	282	305	403	419	457	502
L1 (BW)	216	282	305	403	419	457	502
L2 (RTJ)	232	298	321	419	435	473	518
Hopen	480	570	625	773	955	1180	1375
D ₀	250	300	300	350	400	450	500
Kg (RF)	35	58	88	152	210	378	623
Kg (BW)	29	49	67	122	188	313	537

按API 6D试验压力 TEST PRESSURE to API 6D

阀体材料 Body material	强度试验 (MPa) Hydrostatic shell test ≥	水密封试验 (MPa) Hydrostatic seat test ≥	阀头水密封试验 (MPa) Hydrostatic back seat test ≥	气密封试验 (MPa) Air closure test ≥
A350 LF2	7.67		5.62	
A 352 LCB	7.20		5.28	
CF8/F304	7.44		5.46	0.4
CF8M/F316				

平板闸阀特点:

开启和关闭扭矩小。
全通径, 流体阻力, 流阻清晰可能。
碳钢成分中硫和磷含量比规定低, 利于抗硫化应力腐蚀和抗氢致裂纹。
O型圈可用Kalrez®材料, 适合含高H₂S的石油与天然气, 并抗高压爆裂破坏。

The features of Slab Gate Valves:

Opening & closing torque are small.
The full bores make the flow resistance small and pig possible.
S and P content are lower than those specified which are beneficial to SSC-resistant and HIC-resistant.
O-rings can be made of Kalrez®, suitable to oil crude and natural gas containing high H₂S content and RGD-resistant.



抗硫平板闸阀 600#压力级按API 6D、NACE MR0175/ISO15156、API 6FA设计与制造

SULFUR RESISTANT SLAB GATE VALVE ANSI CLASS 600# as per API 6D, NACE MR0175/ISO15156 and API 6FA
口径2" -12" 明杆 OS & Y In size 2" -12"

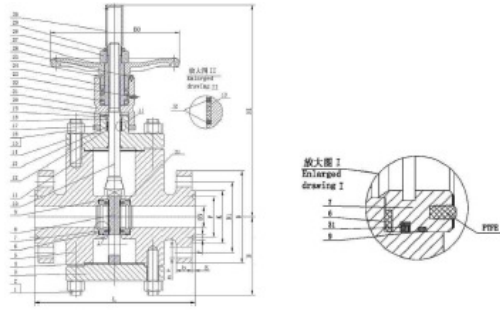

主要阀门零件材料
STANDARD MATERIAL SPECIFICATIONS OF MAIN VALVE PARTS

零件名称/Part name	碳钢系列 Carbon steel series		不锈钢系列 Stainless steel series			
5 阀体Body	A350 LF2	A 352 LCB	A 351 CF8	A 182 F304	A 351 CF8M	A 182 F316
14 阀盖Bonnet	A 350 LF2*	A 352 LCB*	A 351 CF8	A 182 F304	A 351 CF8M	A 182 F316
1/15 螺柱 Studs	A193 B7M/A320 L7M		A193 B8M			
2/16 螺母 Nuts	A184 2HM/7M		A194 8M			
3 底座 Bottom	A350 LF2	A 352 LCB	A 351 CF8	A 182 F304	A 351 CF8M	A 182 F316
4/11 垫片Gasket	缠绕式垫片Spiral wound gasket					
6/9 O型圈 O-ring	Kalrez(R)/FKM/HNBR**					
7 阀座 Seat ring	A350 LF2+STL+ENP+PTFE	A 182 F304+STL+ENP+PTFE	A 182 F316+STL+ENP+PTFE			
8 闸板 Gate	A350 LF2+STL	A 182 F304+STL	A 182 F316+STL			
10 阀杆 Stem	A 276 T316/Inconel 718					
12 填料Packing	底部和顶部各一圈不锈钢丝加强的石墨编织填料 A ring of braided graphite reinforced with stainless steel wire at the bottom and top respectively					
13 填料Packing	预成型柔性石墨环Preformed flexible graphite rings					
19 填料压盖Gland	A 276 T316					
21 叉架 Yoke	A 105	A 182 F304	A 182 F316			
24 阀杆螺母Stem nut	铝青铜或奥氏体球墨铸铁D2 Aluminum bronze or D2					
27 手轮Handwheel	WCB					
31 填料Packing	预成型柔性石墨环Preformed flexible graphite rings					

* 密封环处堆焊316L, 316L is deposited on a backseat.
* 按用户要求, On user's request.

美国标准法兰ANSI B 16.5, 对接焊端口按ANSI B 16.25; RTJ法兰按ANSI B 16.5,
RF flange ends to ANSI B 16.5; BW ends to ANSI B 16.25; RTJ flange ends to ANSI B 16.5.

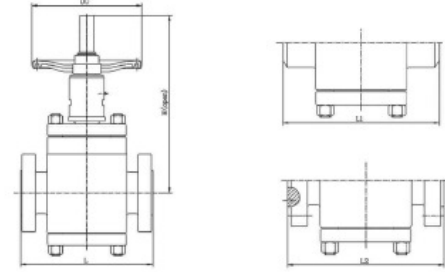

压力级600#平板闸阀之尺寸和重量 DIMENSIONS and WEIGHTS of 600# Slab Gate V

NPS	2	3	4	6	8	10	12
L (RF)	368	381	457	610	737	838	965
L1 (BW)	368	381	457	610	737	838	965
L2 (RTJ)	371	384	460	613	740	841	968
Hopen	494	680	750	965	1135	1398	1525
D _s	300	350	400	500	550	600	650
Kg (RF)	138	156	195	509	677	976	1366
Kg (BW)	114	132	153	415	636	746	1067

按API 6D试验压力TEST PRESSURE to API 6D

阀体材料 Body material	强度试验 (MPa) Hydrostatic shell test ≥	密封试验 (MPa) Hydrostatic seat test ≥	钢壳水压试验 (MPa) Hydrostatic back seat test ≥	气密性试验 (MPa) Air closure test ≥
A350 LF2	15.32		11.23	
A 352 LCB	14.40		10.58	
CF8/F304	14.90		10.92	0.4
CF8M/F316				

平板闸阀特点:

开点和关闭扭矩小。
全通径, 流体阻力小, 流球清晰可能。
碳钢成分中硫和磷含量比规定低, 利于抗硫化应力裂纹和抗脆裂裂纹。
O型圈可用Kalrez™材料, 适合含H₂S的石油与天然气, 并抗高压爆裂破坏。

The features of Slab Gate Valves:

Opening & closing torque are small.
The full bores make the flow resistance small and pig possible.
S and P content are lower than those specified which are beneficial to SSC-resistant and HIC-resistant.
O-rings can be made of Kalrez™, suitable to oil crude and natural gas containing high H₂S content and RGD-resistant.



抗硫平板闸阀900#压力级按API 6D、NACE MR0175/ISO15156、API 6FA设计与制造

SULFUR RESISTANT SLAB GATE VALVE ANSI CLASS 900# as per API 6D, NACE MR0175/ISO15156 and API 6FA
口径2" -12" 明杆 OS & Y In size 2" -12"

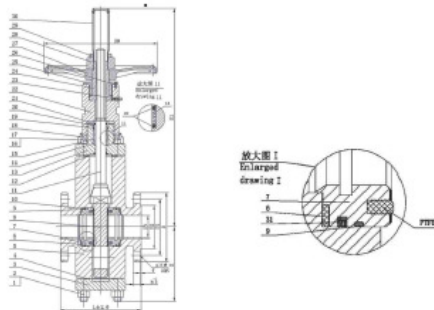

主要阀门零件材料
STANDARD MATERIAL SPECIFICATIONS OF MAIN VALVE PARTS

零件名称/Part name	碳钢系列 Carbon steel series		不锈钢系列 Stainless steel series			
5 阀体Body	A350 LF2	A 352 LCB	A 351 CF8	A 182 F304	A 351 CF8M	A 182 F316
13 阀盖Bonnet	A 350 LF2*	A 352 LCB*	A 351 CF8	A 182 F304	A 351 CF8M	A 182 F316
1/16 螺柱 Studs	A193 B7M/A320 L7M		A193 B8M			
2/17 螺母 Nuts	A184 2HM/7M		A194 8M			
3 底座 Bottom	A350 LF2	A 352 LCB	A 351 CF8	A 182 F304	A 351 CF8M	A 182 F316
4/12 垫片Gasket	缠绕式垫片Spiral wound gasket					
6/9 O型圈 O-ring	Kalrez(R)/FKM/HNBR**					
7 阀座 Seat ring	A350 LF2+STL+ENP+PTFE	A 182 F304+STL+ENP+PTFE	A 182 F316+STL+ENP+PTFE			
8 闸板 Gate	A350 LF2+STL	A 182 F304+STL	A 182 F316+STL			
11 阀杆 Stem	A 276 T316/Inconel 718					
15 填料Packing	底部和顶部各一圈不锈钢丝加强的石墨编织填料 A ring of braided graphite reinforced with stainless steel wire at the bottom and top respectively					
14 填料Packing	预成型柔性石墨环Preformed flexible graphite rings					
19 填料压盖Gland	A 276 T316					
24 阀杆螺母Stem nut	A 105	A 182 F304	A 182 F316			
22 叉架 Yoke	铝青铜或奥氏体球墨铸铁D2 Aluminum bronze or D2					
27 手轮Handwheel	WCB					
31 填料Packing	预成型柔性石墨环Preformed flexible graphite rings					

* 密封环处堆焊316L, 316L is deposited on a backseat.
* 按用户要求, On user's request.

美国标准法兰ANSI B 16.5, 对接焊端口按ANSI B 16.25; RTJ法兰按ANSI B 16.5,
RF flange ends to ANSI B 16.5; BW ends to ANSI B 16.25; RTJ flange ends to ANSI B 16.5.

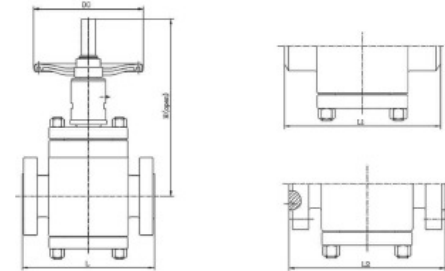

900#标准闸阀之尺寸和重量 DIMENSIONS and WEIGHTS of 900# Gate V.

NPS	2	3	4	6	8	10	12
L (RF)	292	356	432	559	660	787	838
L1 (BW)	292	356	432	559	660	787	838
L2 (RTJ)	285	359	435	562	663	790	841
Hopen	500	680	750	965	1135	1398	1525
D _s	300	300	350	400	450	500	600
Kg (RF)	93	165	297	413	536	795	1050
Kg (BW)	83	174	275	367	466	666	950

按API 6D试验压力TEST PRESSURE to API 6D

阀体材料 Body material	强度试验 (MPa) Hydrostatic shell test ≥	密封试验 (MPa) Hydrostatic seat test ≥	钢壳水压试验 (MPa) Hydrostatic back seat test ≥	气密性试验 (MPa) Air closure test ≥
A350 LF2	22.98		16.85	
A 352 LCB	21.62		18.85	
CF8/F304	22.34		16.38	0.4
CF8M/F316				

平板闸阀特点:

开点和关闭扭矩小。
全通径, 流体阻力小, 流球清晰可能。
碳钢成分中硫和磷含量比规定低, 利于抗硫化应力裂纹和抗脆裂裂纹。
O型圈可用Kalrez™材料, 适合含H₂S的石油与天然气, 并抗高压爆裂破坏。

The features of Slab Gate Valves:

Opening & closing torque are small.
The full bores make the flow resistance small and pig possible.
S and P content are lower than those specified which are beneficial to SSC-resistant and HIC-resistant.
O-rings can be made of Kalrez™, suitable to oil crude and natural gas containing high H₂S content and RGD-resistant.



4" -600#平板闸阀
4" -600# Slab gate valve

2"-600#和4"-600#平板闸阀已通过按API 6FA的耐火试验, 其证书将发出。右面为耐火试验后照片。

2"-600# and 4"-600# Slab gate valve Have past a fire safe test as per API6FA. The right is the photo after the test.



CERTIFICATE ◆ CERTIFICADO ◆ СЕРТИФИКАТ ◆ 認證證書 ◆ CERTIFICATE ◆ CERTIFICAT



CERTIFICATE

(Certificate of conformity with technical requirements in:)
API SPEC 6FA Third Edition, April 1999

Certificate No.: 214171
Ref. Test report No.: 214172

Name and postal address of manufacturer: **Shanghai Valve Factory Co., Ltd.**
No.115 Zhonghai Road, Anting Town,
Shanghai, P.C. 201814, P. R. China

We hereby certify that the fire test on below valves have been conducted at the laboratory designated by manufacturer and witnessed by TÜV inspector according to requirements of API SPEC 6FA Third Edition, April 1999. The testing results of valves meet the requirements of API SPEC 6FA.

1. Description of Test Valve:

Type of Test Valve	KZ431-600Lb NPS4"
Description of Valve	Forging Parallel Gate Valve
Valve Size, (NPS)	4"
Pressure Rating (API Class)	600
Valve Body Material	ASTM A350 LF2

2. Qualified Range of Valves:

Type	Parallel Gate Valve
Description of Valves	Parallel Gate Valve
Qualified Pressure Ratings (Class) (according to API 6FA Table 2)	600, 900
Qualified Sizes (NPS) (according to API 6FA Table 2)	4", 6", 8"
Qualified Marking (according to API 6FA Para.7)	Qualified valves shall be permanently marked: 6FA

Remark: the technical data of test valves see back of this certificate appendix 1.

This certificate is issued according to API SPEC 6FA Third Edition, April 1999, based upon the result of testing report on above mentioned test valve. The additional valves qualification shall be limited on similar valves of same basic design as the test valve and same nonmetallic materials as the test valve in the seal-to-closure member seat, seat-to-body seat, stem seal, and body joint and seal according to API SPEC 6FA Third Edition, April 1999, Para.4.8.

Shanghai, March 27, 2012
(Place, date)



TUV SUD Industrial Service GmbH

TUV颁发的耐火试验证书, 实际上我厂具有口径2"至8", 压力级600#和900#范围的资质
Certificate of fire safe test issued by TÜV, actually we are qualified for Slab gate valves of NPS 2" - 8", pressure class 600# and 900#

锻钢固定球阀
Forged Ball Valve — Trunnion Ball

设计制造标准

- 设计标准: API 6D, NACE MR-0175
- 结构长度: API 6D
- 法兰连接: 2" - 24" ASME B16.5 26" - 42" ASME B16.47
- 焊接标准: ASME B16.25
- 检验与试验标准: API 6D
- 火级试验: API 6FA

主要结构

- 固定球
- 三段式锻造
- 全通径设计
- 自动泄压设计
- 翼杆防飞设计
- 可充用软密封或金属密封
- 防火设计
- 软密封阀门防静电设计
- 密封脂或润滑油注入设计(可选)

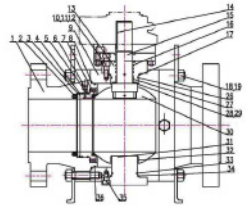

Design and Fabrication Specifications

- Design Specification: API 6D, NACE MR-0175
- Face to Face (End to End): API 6D
- End Flange: 2" - 24" ASME B16.5 26" - 42" ASME B16.47
- BW End: ASME B16.25
- Inspection & Testing: API 6D
- Fire Test: API 6FA

Main Construction

- Trunnion Mounted Ball Valve
- Three Pieces Forged Body
- Full Port Design
- Pressure Self-relief
- Anti-blowout Stem Design
- Choice of Soft or Metal-to-metal Seated Designs
- Fire Safety Design
- Anti-static Device for Soft-seated Valves
- Sealant or Lubrication Injection Points Design (Optional)

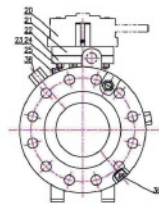

材料表 Material List

No.	名称 Name	材料表 Material List			
1	左右体 End Adaptor	A105	A350 LF2	A182 F304	A182 F316
2	弹簧 Springs	Inconel X - 750			
3	压圈 Pressure Ring	A105+ENP	A350 LF2+ENP	A182 F304	A182 F316
5 16 26 36	O型圈 O-ring	氟橡胶 Viton			
	阀座 Seat	A105+ENP	304		316
	软密封 Soft-seated	阀座密封圈 Sealing Ring 增强 PTFE			
6 7 30	球体 Ball	A105+ENP		316"	
	硬密封 Metal-seated	阀座 Seat	A105+WC	316	316
		球体 Ball	A105+WC	316"+WC	
8 34	密封垫 Gasket	304+柔性石墨 304+Graphite		316+柔性石墨 316+Graphite	



材料表 Material List

No.	名称 Name	材料表 Material List							
9	中间体 Body	A105	A350 LF2	A162 F304	A182 F316				
10 11 12	螺钉 Screw	A193 B7M	A193 B7M	A193 B7M+镀镍	A193 B7M+Nickle Plated				
13	填料函 Stuffing Box	A105+ENP	A305LF2+ENP	A182 F304	A182 F304				
14	键 Key	45	45			17-4PH			
15	阀杆 Stem	A276 414	A276 414			17-4PH			
4 17	密封垫 Gasket	柔性石墨 Graphite							
18 23	螺栓 Bolts	A193 B7M	A193 B7M	A193 B7M+镀镍	A193 B7M+Nickle Plated				
19 24	螺母 Bolt Nuts	A194 2HM	A194 2HM	A194 2HM+镀镍	A194 2HM+Nickle Plated				
21	下支承板 Upper Adaptor	碳钢 CS							
22	下支承板 Lower Adaptor	碳钢 CS							
25	GF5V注油阀 Grease Injection Valve	304		316					
28	止推垫 Thrust Washer	柔性石墨 Graphite							
29	止推垫 Thrust Washer	PTFE							
31	下轴 Lower Stem	A105+ENP		304		316			
27 32	无油轴承 Bearing	碳钢 CS		不锈钢 SS					
33	GVZ注油阀 Grease Injection Valve	304		316					
34	BSV注油阀 Grease Injection Valve	304		316					
35	螺钉 Screw	A193 B7M	A193 B7M	A193 B7M+镀镍	A193 B7M+Nickle Plated				
38	钢球 Ball	304		316					
39	排油阀 Relief Valve	304		316					

注: class300以上, 球体材料为F61. Ball material is F61 for over class 300.

尺寸及重量 Dimensions and Weights

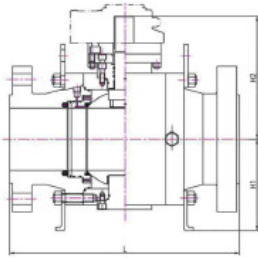

固定球阀 Trunnion Mounted Ball Valve — Class150

GO: 齿轮传动 Gear Operated

规格 Size	L		L1		L2		H1		H2		W		重量 Weight RF
	in	mm	in	mm	in	mm	in	mm	in	mm	in	mm	
2	7	178	8.5	216	7.5	191	3.5	89	5.9	149	15	380	20
2.5	7.5	191	9.5	241	8	203	3.8	96	6.4	162	18.9	480	27
3	8	203	11.14	283	8.5	216	4.3	109	7.2	184	19.7	500	39
4	9	229	12	305	9.5	241	6.2	157	9.6	244	31.5	800	56.5
6	15.5	394	18	457	16	406	7.4	187	11.4	289			148
8	18	457	20.5	521	18.5	470	9.8	250	13.4	341			245
10	21	533	22	559	21.5	546	10.9	276	14.7	373			376
12	24	610	25	635	24.5	622	13.2	336	17.7	450			790
14	27	686	30	762	27.5	699	15.7	400	19.1	485			932
16	30	762	33	838	30.5	775	16.5	420	21	533			1310
18	34	864	36	914	34.5	876	18.5	469	23.3	593			1700
20	38	914	39	991	38.5	927	20.7	525	24.8	626			2300
24	42	1067	45	1143	42.5	1080	24	610	29.4	748			3200
28	49	1245	53	1346			27.9	708	32.3	820			3850
32	54	1372	60	1524			31.0	790	34.2	868			6220
36	60	1524	68	1727			33.3	847	40.3	1024			8200

固定球阀 Trunnion Mounted Ball Valve — Class300

GO: 齿轮传动 Gear Operated

规格 Size	L		L1		L2		H1		H2		W		重量 Weight RF
	in	mm	in	mm	in	mm	in	mm	in	mm	in	mm	
2	8.5	216	8.5	216	9.1	232	3.5	89	5.9	149	15	380	25
2.5	9.5	241	9.5	241	10.1	257							40
3	11.1	283	11.1	283	11.7	298	4.3	109	7.2	184	19.7	500	45
4	12	305	12	305	12.6	321	6.2	157	9.6	244	31.5	800	77.5
6	18	403	18	457	16.5	419	7.5	190	11.4	289			180
8	20	502	20.5	521	20.4	518	9.8	250	13.4	341			285
10	22.4	568	22	559	23	584	10.9	276	14.7	373			470
12	25	635	25	635	26.1	664	13.2	336	17.7	450			950
14	30	762	30	762	30.6	776	15.7	400	19.1	485			1200
16	33	838	33	838	33.6	854	16.5	420	21	533			1600
18	36	914	36	914	36.6	930	18.7	475	23.3	593			2200
20	39	991	39	991	39.8	1010	20.8	529	25.2	636			2580
24	45	1143	45	1143	45.9	1165	24.2	615	29.9	759			4080
28	53	1346	53	1346	54	1372	28.5	723	33	838			5250
32	60	1524	60	1524	61.1	1553	31.3	795	36.3	922			7520
36	68	1727	68	1727	69.1	1766	35.4	898	41.2	1045			10800

注: API 6D第22版6-300Lb RF结构长度L1为403mm, L&L1 of API 6D Rev.22 for RF is 403mm.

固定球阀 Trunnion Mounted Ball Valve — Class400

GO: 齿轮传动 Gear Operated

规格 Size	L		L1		L2		H1		H2		W		重量 Weight RF
	in	mm	in	mm	in	mm	in	mm	in	mm	in	mm	
2	11.5	292	11.5	292	11.6	295	3.1	80	6	152	22.8	580	29
2.5	13	330	13	330	13.1	333	3.7	95	7	178	23.6	600	35
3	14	356	14	356	14.1	359	4.5	115	8.3	212	26.0	650	57
4	16	406	16	406	16.1	410	6.9	176	9.4	240	31.5	800	97
6	19.5	495	19.5	495	19.5	498	8	203	11.8	300			216
8	23.5	597	23.5	597	23.6	600	11.6	295	14	356			370
10	26.5	673	26.5	673	26.6	676	13.7	349	16.6	422			705
12	30	762	30	762	30.1	765	14.8	375	18.3	465			1026
14	32.5	826	32.5	826	32.6	829	17.5	444	20.5	520			1320
16	35.5	902	35.5	902	35.6	905	18.5	471	22.2	563			1920
20	41.5	1054	41.5	1054	41.7	1060	21.6	548	26.5	725			3225
24	46.5	1232	46.5	1232	46.9	1241	26.5	672	33.8	859			5300
28	55	1397	55	1397	55.5	1410	31.3	796	39.1	993			8922



固定球阀 Trunnion Mounted Ball Valve — Class600

GO: 齿轮传动 Gear Operated

规格 Size	L		L1		L2		H1		H2		W		重量 Weight RF
	in	mm	in	mm	in	mm	in	mm	in	mm	in	mm	
2	11.5	292	11.5	292	11.6	295	3.1	80	6	152	22.8	580	32
2.5	13	330	13	330	13.1	333	3.7	95	7.0	178	23.6	600	46
3	14	356	14	356	14.1	359	4.5	115	8.3	212	26	710	63
4	17	432	17	432	17.1	435	6.9	176	9.4	240	33.5	850	114
6	22	559	22	559	22.1	562	8	203	11.8	300			244
8	26	660	26	660	26.1	664	11.6	295	14.0	356			469
10	31	787	31	787	31.1	791	13.7	349	16.6	422			810
12	33	838	33	838	33.1	841	14.8	375	18.3	465			1100
14	35	889	35	889	35.1	892	17.5	444	20.5	520			1400
16	39	991	39	991	39.1	994	18.5	471	22.2	563			2200
20	47	1194	47	1194	47.2	1200	21.6	548	26.5	725			3620
24	55	1397	55	1397	55.4	1407	26.5	672	33.8	859			5700
28	61	1549	61	1549	61.5	1562	31.3	796	39.1	993			7500

固定球阀 Trunnion Mounted Ball Valve — Class900

GO: 齿轮传动 Gear Operated

规格 Size	L		L1		L2		H1		H2		W		重量 Weight RF
	in	mm	in	mm	in	mm	in	mm	in	mm	in	mm	
2	14.5	368	14.5	368	14.6	371	4.3	108	6	152			40
2.5	16.5	419	16.5	419	16.6	422	4.5	115	7.4	187			56
3	15	381	15	381	15.1	384	4.7	120	8.0	202			92
4	18	457	18	457	18.1	460	6	152	10.7	272			148.5
6	24	610	24	610	24.1	613	10.6	270	14.2	360			390
8	29	737	29	737	29.1	740	12.7	322	15.5	394			605
10	33	838	33	838	33.1	841	16.5	420	19.8	502			1100
12	38	965	38	965	38.1	968	18.5	470	22.5	572			1500
14	40.5	1029	40.5	1029	40.9	1038	20.1	510	26.6	675			1922
16	44.5	1130	44.5	1130	44.9	1140	23.6	600	30	762			2600
18	48	1219	48	1219									



尺寸及重量 Dimensions and Weights

浮动球阀 Floating Ball Valve - Class150

规格 Size	L		H		W		重量Weight Kg
	in	mm	in	mm	in	mm	
0.5	4.3	108	2.3	59	5.1	130	2.5
0.75	4.6	117	2.5	63	5.1	130	3
1	5	127	3	75	6.3	160	5
1.5	6.5	165	3.7	95	9.1	230	7
2	7	178	4.2	107	9.1	230	10
2.5	7.5	191	5.6	142	15.7	400	15
3	8	203	6	152	15.7	400	19
4	9	229	7	178	25.6	650	33
6	15.5	394	10.7	272	41.3	1050	93
8	18	457	13.5	342	55.5	1410	160

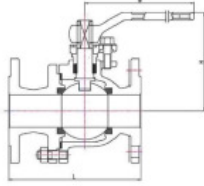

浮动球阀 Floating Ball Valve - Class300

规格 Size	L		H		W		重量Weight Kg
	in	mm	in	mm	in	mm	
0.5	5.5	140	2.3	59	5.1	130	3
0.75	6	152	2.5	63	5.1	130	4
1	6.5	165	3	75	6.3	160	6
1.5	7.5	191	3.7	95	9.1	230	11
2	8.5	216	4.2	107	9.1	230	15
2.5	9.5	241	5.6	142	15.7	400	24
3	11.1	283	6	152	15.7	400	30
4	12	305	7	178	25.6	650	55
6	18	457	10.7	272	41.3	1050	118
8	20	502	13.5	342	55.5	1410	200

注: API 6D第22条6-300Lb球阀门腔长度L为403mm. L of API 6D Rev.22 for RF valve is 403.

浮动球阀 Floating Ball Valve - Class600

规格 Size	L		H		W		重量Weight Kg		
	in	mm	in	mm	in	mm			
0.5	6.5	165	6.5	165	2.3	59	6.3	160	8
0.75	7.5	191	7.5	191	2.5	63	6.3	160	11
1	8.5	216	8.5	216	2.95	75	9.1	230	15
1.5	9.5	241	9.5	241	3.7	95	15.7	400	19
2	11.5	292	11.6	295	6.6	167	15.7	400	25
3	14	356	14.1	359	7.8	198	25.6	650	48
4	17	432	17.1	435	7.9	200	41.3	1050	78

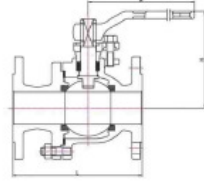

浮动球阀 Floating Ball Valve - Class900

规格 Size	L		H		W		重量Weight Kg		
	in	mm	in	mm	in	mm			
0.5	8.5	216	8.5	216	5.4	138	6.3	160	15
0.75	9	229	9	229	5.55	141	9.06	230	19
1	10	254	10	254	5.6	143	9.1	230	25

浮动球阀 Floating Ball Valve - Class1500

规格 Size	L		H		W		重量Weight Kg		
	in	mm	in	mm	in	mm			
0.5	8.5	216	8.5	216	5.4	138	6.3	160	15
0.75	9	229	9	229	5.7	144	9.06	230	19
1	10	254	10	254	5.8	147	9.1	230	25

设计制造标准

- 设计标准: GB/T 12237
- 结构长度: GB/T 12221
- 法兰连接: GB/T 9113, JB/T 79
- 检验与试验标准: JB/T 9092

主要结构

- 浮动球
- 二段式铸造壳体
- 全通径设计
- 阀杆防飞设计
- 可选用软密封或金属密封
- 防火设计
- 软密封阀门防静电设计

Design and Fabrication Specifications

- Design Specification: GB/T 12237
- Face to Face (End to End): GB/T 12221
- End Flange: GB/T 9113, JB/T 79
- Inspection & Testing: JB/T 9092

Main Construction

- Floating Ball Valve
- Two Pieces Casting Body
- Full Port Design
- Anti-blowout Stem Design
- Choice of Soft or Metal-to-metal Seated Designs
- Fire Safety Design
- Anti-static Device for Soft-seated valves

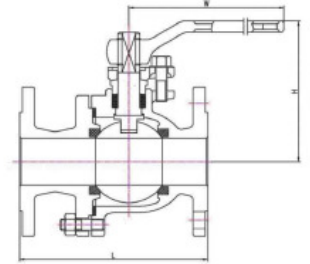

材料表 Material List

公称压力PN	公称通径DN	mm															
		15	20	25	32	40	50	65	80	100	125	150	200				
1.6MPa	L	mm	130	130	140	165	165	203	222	241	305	356	394	457			
	H	mm	78	84	95	132	135	150	180	215	250	285	330	370			
	W	mm	140	160	160	200	250	300	350	400	500	600	800	800			
	Wt	Kg	2.5	3	4.5	5.7	7	9.5	15	19	33	58	81	95			
2.5MPa	L	mm	130	130	140	165	165	203	222	241	305	356	394	457			
	H	mm	82	98	104	134	140	155	180	222	253	288	335	372			
	W	mm	140	160	160	200	250	300	350	400	500	600	800	800			
	Wt	Kg	3	4	6	10	12	16	20	30	40	65	85	98			
4.0MPa	L	mm	140	152	165	180	200	230	290	310	350	400	403				
	H	mm	103	112	124	138	156	172	197	225	258	276	295				
	W	mm	140	160	180	250	250	350	400	500	600	1000	1200				
	Wt	Kg	3	4	6	10	14	20	25	50	70	80	101				



设计制造标准

- 设计标准: GB/T 12237
- 结构长度: GB/T 12221
- 法兰连接: GB/T 9113, JB/T 79
- 检验与试验标准: JB/T 9092

主要结构

- 浮动球
- 铸造壳体
- 全通径设计
- 阀杆防飞设计
- 防火设计
- 防静电设计
- L型或T型

主体材料

- A216 WCB, A351 CF8, A351 CF8M, A351 CF3, A351 CF3M

Design and Fabrication Specifications

- Design Specification: GB/T 12237
- Face to Face (End to End): GB/T 12221
- End Flange: GB/T 9113, JB/T 79
- Inspection & Testing: JB/T 9092

Main Construction

- Floating Ball Valve
- Casting Body
- Full Port Design
- Anti-blowout Stem Design
- Fire Safety Design
- Anti-static Design
- L Port or T Port

Body Material

- A216 WCB, A351 CF8, A351 CF8M, A351 CF3, A351 CF3M

外形尺寸 Dimensions

公称压力PN	公称通径DN	in											
		0.5	0.75	1	1.5	2	2.5	3	4	5	6	8	
PN16, PN25 Class 150	d	mm	15	20	25	40	50	65	80	100	125	150	200
	L	mm	13	17	24	37	49	64	75	98	123	148	198
	H	mm	70	88	88	132	137	162	170	229	247	315	412
	W	mm	160	230	230	400	400	700	700	1050	1050	600*	600*
PN40, PN64 Class 300	d	mm	13	17	24	37	49	64	75	98	123	148	198
	L	mm	130	150	160	200	230	290	310	350	400	480	600
	H	mm	96	96	96	165	180	241	241	295	390	390	466
	W	mm	160	230	230	400	700	700	1050	1050	800*	600*	800*

注: Note: 蜗轮传动 Worm Gear Drive

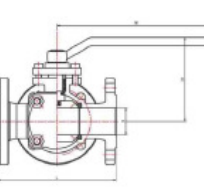
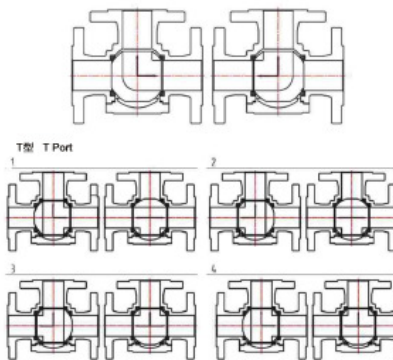
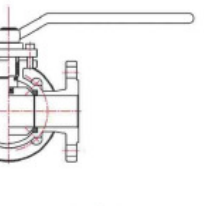

设计制造标准

- 设计标准: GB/T 12237, API 608
- 结构长度: GB/T 12221, ASME B16.10
- 法兰连接: GB/T 9113, JB/T 79, AMSE B16.5
- 检验与试验标准: JB/T 9092, API 598

主要结构

- 浮动球
- 铸造壳体
- 全通径设计
- 阀杆防飞设计
- 防火设计
- 防静电设计

主要材料

- 阀体: A216 WCB, A351 CF8, A351 CF8M, A351 CF3, A351 CF3M
- 夹套: A105, 304, 316

Design and Fabrication Specifications

- Design Specification: GB/T 12237, API 608
- Face to Face (End to End): GB/T 12221, ASME B16.10
- End Flange: GB/T 9113, JB/T 79, AMSE B16.5
- Inspection & Testing: JB/T 9092, API 598

Main Construction

- Floating Ball Valve
- Casting Body
- Full Port Design
- Anti-blowout Stem Design
- Fire Safety Design
- Anti-static Design

Main Material

- Body: A216 WCB, A351 CF8, A351 CF8M, A351 CF3, A351 CF3M
- Jacket: A105, 304, 316

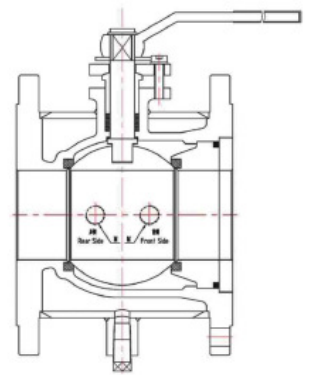

法兰和夹套接管规格 Flange and Jacket Connection Size

DN/NPS	in								
	0.75	1	1.5	2	3	4	6	8	
法兰规格 Flange Size	mm	20	25	40	50	80	100	150	200
	法兰规格 Flange Size	40	50	65	80	150	200	250	300
夹套接管 Jacket Connection Size		ZG3/4"	ZG3/4"	ZG3/4"	ZG3/4"	ZG3/4"	ZG1"	ZG1"	

尺寸及重量 Dimensions and Weights

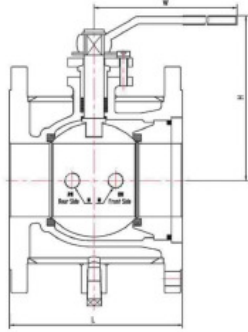

公称压力PN	公称通径DN	mm	20	25	40	50	80	100	125	150	200
1.0MPa	L	mm	117	127	165	178	203	229	356	394	457
	H	mm	65	70	85	120	158	180	252	272	335
	W	mm	160	160	230	230	400	700	800	1100	1500
	WT	Kg	3	5	6	9	21	37	65	96	175
1.6MPa	L	mm	130	140	165	203	241	305	356	394	457
	H	mm	101	106	125	135	193	265	285	310	350
	W	mm	230	230	300	380	450	700	800	1100	1500
	WT	Kg	3.5	5.4	6.5	10	22	38	71	99	182
2.5MPa	L	mm	130	140	165	203	241	305	356	394	457
	H	mm	101	106	125	135	193	252	286	320	370
	W	mm	230	230	300	380	450	700	800	1100	1500
	WT	Kg	4	6	8	12	24	41	78	124	182
4.0MPa	L	mm	152	165	190	216	283	305	381	457	502
	H	mm	108	112	135	142	205	262	295	325	370
	W	mm	320	400	700	800	950	1100	1500	1500	1500
	WT	Kg	5	8	11	15	28	44	82	132	224

压力等级 Class	NPS	in	0.75	1	1.5	2	3	4	6	8
150Lb	L	mm	117	127	165	178	203	229	394	457
	H	mm	101	106	125	135	193	265	310	350
	W	mm	230	230	300	380	450	700	800	1100
	WT	Kg	3.5	5.4	6.5	10	22	37	65	96
300Lb	L	mm	152	165	190	216	283	305	403	502
	H	mm	118	122	137	148	215	282	325	370
	W	mm	320	400	700	800	950	1100	1300	1500
	WT	Kg	5	8	11	15	28	44	82	132

设计制造标准

- 设计标准: GB/T 12237
- 结构长度: GB/T 12221
- 螺纹连接: GB/T 7306, GB/T12716
- 检验与试验标准: JB/T 9092

主要结构

- 浮动球
- 整体阀体或二段阀体
- 阀杆防飞设计

主要材料

- 阀体: A105, A216 WCB, 304/A351 CF8, 316/A351 CF8M, 304L/A351 CF3, 316L/A351 CF3M.

Design and Fabrication Specifications

- Design Specification: GB/T 12237
- Face to Face (End to End): GB/T 12221
- Thread End: GB/T 7306, GB/T12716
- Inspection & Testing: JB/T 9092

Main Construction

- Floating Ball Valve
- One Piece or Two Piece Body
- Anti-blowout Stem Design

Main Material

- Body: A105, A216 WCB, 304/A351 CF8, 316/A351 CF8M, 304L/A351 CF3, 316L/A351 CF3M.

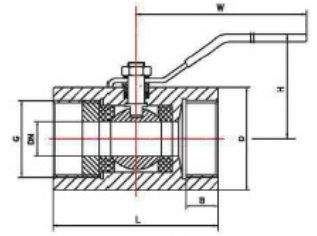

one piece type 整体式

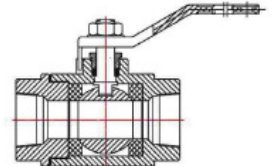

two piece type 分体式

尺寸及重量 Dimensions and Weights

公称压力PN	DN	mm	6	10	15	20	25	32	40	50
1.6~6.4MPa	L	mm	60	60	60	67	73	90	98	112
	H	mm	56	58	58	62	68	75	83	90
	W	mm	110	110	110	110	110	150	150	180
			G1/4	G3/8	G1/2	G3/4	G1	G13/4	G11/2	G2
	B	mm	30	31	32	38	45	54	63	73
	WT	Kg	0.26	0.3	0.36	0.45	0.65	0.95	1.47	1.94

设计制造标准

- 设计标准: API 6D, BS1868, ASME B16.34
- 结构长度: ASME B16.10, API 6D
- 法兰连接: ASME B16.5
- 焊接连接: ASME B16.25
- 检验与试验标准: API 598, API 6D

主要结构

- 柱接阀盖、旋启式阀瓣、焊接阀座

Design and Fabrication Specifications

- Design Specification: API 6D, BS1868, ASME B16.34
- Face to Face (End to End): ASME B16.10, API 6D
- End Flange: ASME B16.5
- BW End: ASME B16.25
- Inspection & Testing: API 598, API 6D

Note:

- *Meel NACE MR-0175 on Request

Main Construction

- Bolted Cover, Swing Type Disc, Welded Seat Ring

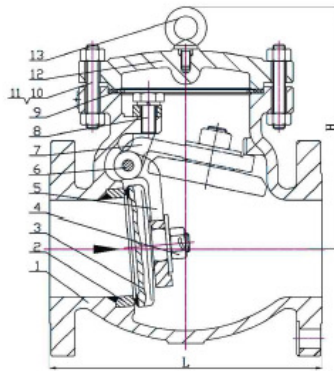

材料表 Material List

No.	Name	名称	Material List 材料表				
1	Body	阀体	A216 WCB	A352 LCB	A217 WC6	A351 CF8	A351 CF8M
2	Seat Ring	阀座	A105	A350 LF2	A182 F11	A182 F304	A182 F316
	Seat Surface	阀座密封面	13Cr, 304, 316, STL	STL	304, STL	316, STL	
3	Disc	阀瓣	A216 WCB	A352 LCB	A217 WC6	A351 CF8	A351 CF8M
	Disc Surface	阀瓣密封面	13Cr, 304, 316, STL	STL	304, STL	316, STL	
4	Disc Nut	阀瓣螺母		SS不锈钢	304	316	
5	Hinge	铰臂	A216 WCB	A352 LCB	A217 WC6	A351 CF8	A351 CF8M
6	Hinge Pin	铰轴	F6a	F304	F316	F316	
7	Bearing Bracket	吊架	A216 WCB	A352 LCB	A217 WC6	A351 CF8	A351 CF8M
8	Bolt	吊装螺栓	A193 B7	A320 L7	A193 B16	A193 B8	A193 B8M
9	Gasket	垫片	304/316+柔性石墨304/316+Graphite		316+柔性石墨316+Graphite		
10	Cover Bolt	中法兰螺栓	A193 B7	A320 L7	A193 B16	A193 B8	
11	Cover Bolt Nut	中法兰螺母	A194 2H	A194 4	A194 7	A194 8	
12	Cover	阀盖	A216 WCB	A352 LCB	A217 WC6	A351 CF8	A351 CF8M
13	Eye Bolt	吊环螺钉		CS碳钢		SS不锈钢	

材料表 Material List

压力等级 Class	规格 Size	in	mm															
			2	2.5	3	4	6	8	10	12	14	16	18	20	24			
150	L/L1 RF/BW	in	8	8.5	9.5	11.5	14	19.5	24.5	27.5	31	34	38.5	38.5	51			
		mm	203	216	241	292	356	495	622	699	787	864	978	978	1295			
	L2 RTJ	in	8.5	9	10	12	14.5	20	25	28	31.5	34.5	39	39	51.5			
		mm	216	229	254	305	368	508	635	711	800	876	991	991	1308			
	H(=)	in	5.9	6.3	7.1	8.7	13.4	15.7	18.1	20.9	22.8	23.6	25.6	27.6	30.7			
		mm	150	160	180	220	340	400	460	530	580	600	650	700	780			
重量-Weight	RF	kg	16	25	34	46	89	130	240	337	471	575	825	956	1275			
	RF/BW	kg	16	25	34	46	89	130	240	337	471	575	825	956	1275			
300	L/L1 RF/BW	in	10.5	11.5	12.5	14	17.5	21	24.5	28	33	34	38.5	40	53			
		mm	267	292	318	356	445	533	622	711	838	864	978	1016	1346			
	L2 RTJ	in	11.12	12.12	13.12	14.62	18.12	21.62	25.12	28.62	33.62	34.62	39.12	40.75	53.88			
		mm	282	308	333	371	460	549	638	727	854	879	994	1035	1369			
	H(=)	in	6.7	7.1	8.3	11.4	13.8	16.9	18.9	21.7	24.4	25.5	27.2	29.1	31.5			
		mm	170	180	210	290	350	430	480	550	620	650	690	740	800			
重量-Weight	RF	kg	26	32	53	73	157	234	384	450	650	800	970	1350	2210			
	RF/BW	kg	26	32	53	73	157	234	384	450	650	800	970	1350	2210			
600	L/L1 RF/BW	in	11.5	13	14	17	22	26	31	33	35	39						
		mm	292	330	356	432	559	660	787	838	889	991						
	L2 RTJ	in	11.62	13.12	14.12	17.12	22.12	26.12	31.12	33.12	35.12	39.12						
		mm	295	333	359	435	562	663	790	841	892	994						
	H(=)	in	7.5	8.3	9.1	11.8	14.6	17.7	19.7	22.4	25.2	26.4						
		mm	190	210	230	300	370	450	500	570	640	670						
重量-Weight	RF	kg	33	49	62	95	195	360	465	725	875	1075						
	RF/BW	kg	33	49	62	95	195	360	465	725	875	1075						

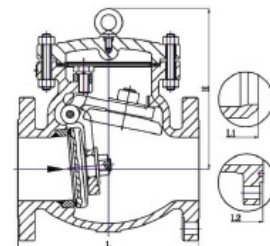



尺寸及重量Dimensions and Weights

压力等级 Class	规格 Size	尺寸 (mm)							
		in	2	2.5	3	4	6	8	10
900	LL1 RF/BW	in	14.5	16.5	15	18	24	29	33
		mm	368	419	381	457	610	737	838
	L2 RTJ	in	14.62	16.62	15.12	16.12	24.12	29.12	33.12
		mm	371	422	384	460	613	740	841
	H (≈)	in	11.6	11.8	11.8	12.8	17.3	19.9	26.2
		mm	295	300	300	325	440	505	665
重量 Weight	RF	Kg	70	91	100	150	305	510	850
1500	LL1 RF/BW	in	14.5	16.5	18.5	21.5	27.75	32.75	39
		mm	368	419	470	546	705	832	991
	L2 RTJ	in	14.62	16.62	18.62	21.62	28	33.13	39.38
		mm	371	422	473	549	711	842	1000
	H (≈)	in	11.6	11.8	13.4	16.3	20.1	26.8	29.8
		mm	295	300	341	415	510	680	756
重量 Weight	RF	Kg	70	100	150	245	550	1010	1550

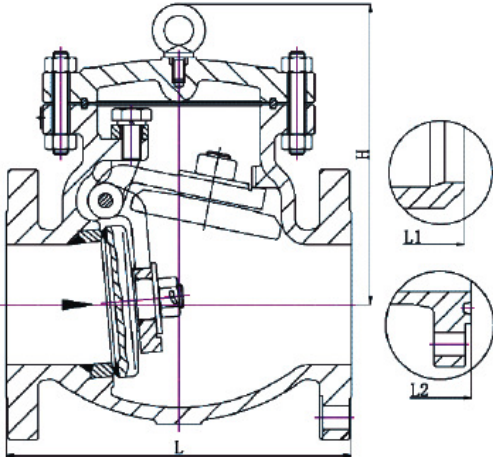

设计制造标准

- 设计标准: GB/T 12236, GB/T 12224
- 结构长度: GB/T12221
- 法兰连接: GB/T 9113, JB/T79
- 焊接连接: GB/T12224
- 检验与试验标准: JB/T9092

注
*如需满足SY/T 0599要求

主要结构

- 栓接阀盖、旋启式阀瓣、焊接阀座

Design and Fabrication Specifications

- Design Specification: GB/T 12236, GB/T 12224
- Face to Face (End to End): GB/T12221
- End Flange: GB/T 9113, JB/T79
- BW End: GB/T12224
- Inspection & Testing: JB/T9092

Note:
*Meet SY/T 0599 on Request

Main Construction

- Bolted Cover, Swing Type Disc, Welded Seat Ring

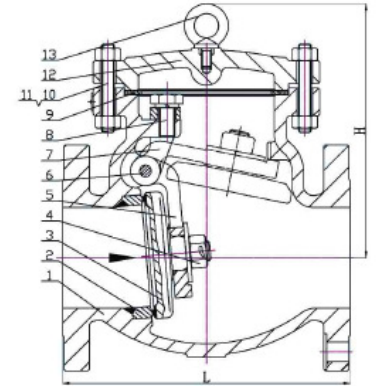

材料表 Material List

No.	Name	名称	Material List 材料表-美标					
1	Body	阀体	WCB	LCB	WC6	CF8	CF8M	
2	Seat Ring	阀座	A105	L2	F11	304	316	
	Seat Surface	阀座密封面	13Cr, 304, 316, STL	STL	304, STL	316, STL		
3	Disc	阀瓣	WCB	LCB	WC6	CF8	CF8M	
	Disc Surface	阀瓣密封面	13Cr, 304, 316, STL	STL	304, STL	316, STL		
4	Disc Nut	阀瓣螺母	304					316
5	Hinge	摇臂	WCB	LCB	WC6	CF8	CF8M	
6	Hinge Pin	销轴	Cr13	Cr13	17-4PH			
7	Bearing Bracket	吊架	WCB	LCB	WC6	CF8	CF8M	
8	Bolt	吊架螺栓	35CrMoA	A320 L7	A193 B16	304	316	
9	Gasket	垫片	304/316+柔性石墨				316+柔性石墨	
			304/316+Graphite				316+Graphite	
10	Cover Bolt	中法兰螺栓	A193 B7	A320 L7	A193 B16	A193 B8		
11	Cover Bolt Nut	中法兰螺母	A194 2H	A194 4	A194 4	A194 8		
12	Cover	阀盖	WCB	LCB	WC6	CF8	CF8M	
13	Eye Bolt	吊环螺钉	CS碳钢					SS不锈钢



尺寸及重量Dimensions and Weights

公称压力 PN	公称口径 DN	mm	尺寸 (mm)											
			50	65	80	100	150	200	250	300	350	400		
1.6MPa	L	mm	230	290	310	350	480	500	550	650	750	850		
	H	mm	135	142	165	180	233	304	348	390	430	468		
	Wt	Kg	21	28	38	58	130	210	294	367	410	461		
2.5MPa	L	mm	230	290	310	350	480	550*	650*	750*	850*	950*		
	H	mm	160	175	185	220	276	350	410	430	518	560		
	Wt	Kg	22	29	38	61	132	213	297	372	415	480		
4.0MPa	L	mm	230	290	310	350	480	550*	650*	750*	850*	950*		
	H	mm	164	173	185	220	276	342	401	423	455	510		
	Wt	Kg	22	29	38	61	132	213	297	372	415	480		
6.4MPa	L	mm	300	340	380	430	550	650	775	900	1025	1150		
	H	mm	177	197	212	248	330	385	445	474	514	616		
	Wt	Kg	27	37	57	89	184	266	396	643	815	1234		
10.0MPa	L	mm	300	340	380	430	550	650	775	900	1025	1150		
	H	mm	180	200	220	250	330	405	450	500	540	620		
	Wt	Kg	38	54	71	117	276	420	615	905	1095	1435		

注按GB12221系列22

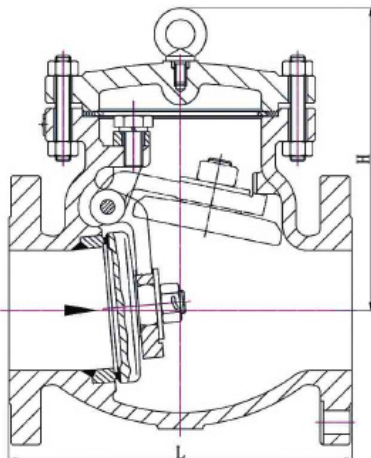

设计制造标准

- 设计标准: GB/T 12235, GB/T 12224
- 结构长度: GB/T12221
- 法兰连接: GB/T 9113, JB/T79
- 焊接连接: GB/T12224
- 检验与试验标准: JB/T9092

注
*如需满足SY/T 0599要求

主要结构

- 栓接阀盖、升降式阀瓣

Design and Fabrication Specifications

- Design Specification: GB/T 12235, GB/T 12224
- Face to Face (End to End): GB/T12221
- End Flange: GB/T 9113, JB/T79
- BW End: GB/T12224
- Inspection & Testing: JB/T9092

Note:
*Meet SY/T 0599 on Request

Main Construction

- Bolted Cover, Lift Type Disc

材料表 Material List

No.	Name	名称	Material List 材料表-美标					
1	Body	阀体	WCB	LCB	WC6	CF8	CF8M	
	Seat Surface	阀座密封面	13Cr, 304, 316, STL	STL	304, STL	316, STL		
2	Disc	阀瓣	20Cr13	LCB	WC6	CF8	CF8M	
	Disc Surface	阀瓣密封面	20Cr13	13Cr, 304, 316, STL	STL	304, STL	316, STL	
3	Gasket	垫片	304/316+柔性石墨304/316+Graphite					316+柔性石墨 316+Graphite
4	Cover Bolt	中法兰螺栓	A193 B7	A320 L7	A193 B16	A193 B8		
5	Cover Bolt Nut	中法兰螺母	A194 2H	A194 4	A194 4	A194 8		
6	Cover	阀盖	WCB	LCB	WC6	CF8		
7	Eye Bolt	吊环螺钉	CS碳钢					SS不锈钢

尺寸及重量Dimensions and Weights

公称压力 PN	公称口径 DN	mm	尺寸 (mm)									
			25	32	40	50	65	80	100	125	150	200
1.6MPa	L	mm	160	180	200	230	290	310	350	400	480	600
	H	mm	80	85	95	105	120	130	140	155	180	215
	Wt	Kg	5	7	9	10	20	30	39	50	70	161
2.5MPa	L	mm	160	180	200	230	290	310	350	400	480	600
	H	mm	120	130	135	149	160	169	194	222	255	305
	Wt	Kg	6	9	12	15	23	30	44	65	99	190
4.0MPa	L	mm	160	180	200	230	290	310	350	400	480	600
	H	mm	120	130	135	149	160	169	194	222	255	305
	Wt	Kg	6	12	14	18	27	36	50	75	119	217
6.4MPa	L	mm	230	260	300	340	380	430	500	550	650	850
	H	mm	135	140	168	170	188	205	230	230	265	310
	Wt	Kg	13	14	20	23	37	46	68	85	131	235
10.0MPa	L	mm	230	260	290	300	340	380	430	500	550	650
	H	mm	145	150	185	187	205	225	250	250	290	340
	Wt	Kg	19	21	30	35	49	60	76	103	186	325



铸钢闸阀 Cast Steel Gate Valve

设计制造标准

- 设计标准: API 600, ASME B16.34
- 结构长度: ASME B16.10
- 法兰连接: 2"-24" ASME B16.5, 26"-42" MSS SP-44
- 焊接连接: ASME B16.25
- 检验与试验标准: API 598

注
★如需要可满足NACE MR-0175要求

主要结构

- 明杆外螺纹和支架、升降杆、弹性闸板、检修侧盖、焊接闸底
- 推力轴承及分离式闸盖支架用于大口径阀门

Design and Fabrication Specifications

- Design Specification: API 600, ASME B16.34
- Face to Face (End to End): ASME B16.10
- End Flange 2"-24" ASME B16.5, 26"-42" MSS SP-44
- BW End: ASME B16.25
- Inspection & Testing: API 598

Note:
★Meet NACE MR-0175 on Request

Main Construction

- OS&Y, Rising Stem, Flexible Wedge, Bolted Bonnet, Welded Seat Ring
- Thrust Bearing and Separated Bonnet/Yoke Used for Larger Size Valve

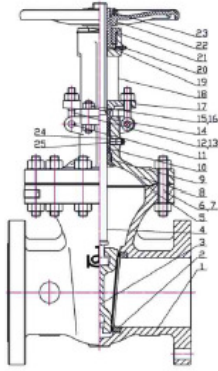

No.	Name	名称	Material List 材料表-表标					
1	Body	阀体	A216 WCB	A352 LCB	A217 WC6	A217 C5	A351 CF8	A351 CF8M
2	Seat Ring	阀座	A105	A350 LF2	A182 F11	A182 F5	A182 F304	A182 F316
	Seat Surface	阀座密封面	13Cr, 304, 316, STL				304, STL	316, STL
3	Wedge	闸板	A216 WCB	A352 LCB	A217 WC6	A217 C5	A351 CF8	A351 CF8M
	Wedge Surface	闸板密封面	13Cr, 304, 316, STL				304, STL	316, STL
4	Stem(1)	阀杆(1)			A182 F6a, F304, F316		A182 F304	A182 F316
5	Gasket	垫片	304/316+柔性石墨304/316+Graphite			316+柔性石墨316+Graphite		
6	Bonnet Bolt	中法兰螺栓	A193 B7	A320 L7		A193 B16		A193 B8
7	Bonnet Bolt Nut	中法兰螺母	A194 2H	A194 4		A194 7		A194 8
8	Bonnet	阀盖	A216 WCB	A352 LCB	A217 WC6	A217 C5	A351 CF8	A351 CF8M
9	Backseat(1)	上密封座(1)			A182 F6a, F304, F316		A182 F304	A182 F316
10	Packing	填料	编织石墨+柔性石墨 Braided Graphite +Die Formed Graphite Rings					
11	Eye Bolt Pin	销			35			12Cr13
12	Gland Eye Bolt	活节螺栓	A193 B7	A320 L7		A193 B16		A193 B8
13	Eye Bolt Nut	活节螺栓螺母	A194 2H	A194 4		A194 7		A194 8
14	Gland (1)	填料压套(1)			A182 F6a, F304, F316		A182 F304	A182 F316
15	Yoke Bolt(2)	支架螺栓(2)	A193 B7	A320 L7		A193 B16		A193 B8
16	Yoke Bolt Nut(2)	支架螺母(2)	A194 2H	A194 4		A194 7		A194 8
17	Gland Flange	填料压板	A216 WCB	A352 LCB	A217 WC6	A217 C5	A351 CF8	A351 CF8M
18	Yoke (2)	支架(2)	A216 WCB	A352 LCB	A217 WC6	A217 C5	A351 CF8	A351 CF8M
19	Stem Nut	阀杆螺母			ZCuAl10Fe3, A439 D2			
20	Grease Nipple	油杯			35			SS-不锈钢
21	Retaining Nut	压盖螺母			35			SS-不锈钢
22	Handwheel	手轮			QT400			
23	Handwheel Nut	手轮螺母			35			SS-不锈钢
24	Lantern Ring(3)	引漏环(3)			A182 F6a, F304, F316		304	316
25	Plug(3)	螺塞(3)			CS碳钢		304	316

注: (1)对于WCB阀, 上密封座可用A352 LCB替代。
(2)适用于闸板密封面分离式闸盖。
(3)CS: Carbon Steel

Note: (1)A352 LCB stems are available for WCB valves.
(2)Suitable for valves with separated bonnet and yoke.
(3)Carbon

铸钢闸阀

Cast Steel Gate Valve-----Class 150



铸钢闸阀

Cast Steel Gate Valve-----Class 300

尺寸及重量Dimensions and Weights

GO: 齿轮传动Gear Operated

规格 Size	L		L1		L2		H(—)		W	重量Weight Kg(—)	
	RF	mm	BW	mm	RTJ	mm	开OPEN	mm			
2	7	178	8.5	216	7.5	191	12.7	323	7.9	200	18
2.5	7.5	191	9.5	241	8	203	13.7	347	9.8	250	28
3	8	203	11.12	282	8.5	216	15.1	383	9.8	250	30
4	9	229	12	305	9.5	241	18	457	11.8	300	50
6	10.5	267	15.88	403	11	279	25	635	13.8	350	85
8	11.5	292	16.5	419	12	305	30	762	13.8	350	128
10	13	330	18	457	13.5	343	35.2	895	15.7	400	220
12	14	356	19.75	502	14.5	368	42.5	1080	19.7	500	310
14	15	381	22.5	572	15.5	394	51	1295	23.6	600	450
16	16	406	24	610	16.5	419	56.5	1435	23.6	600	550
18	17	432	26	660	17.5	445	64	1628	25.6	650	700
20	18	457	28	711	18.5	470	72	1829	GO		910
24	20	508	32	813	20.5	521	85.6	2175	GO		1130
26	22	559	34	864	22.5	572	106	2692	GO		1700
28	24	610	36	914	24.5	622			GO		1931
30	24	610	36	914	24.5	622	125.9	3197	GO		2380
32	28	711	38	965	26.5	673			GO		2490
36	28	711	40	1016	28.5	724	147.1	3737	GO		3600

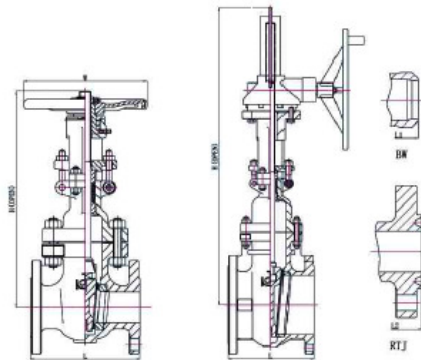

注:
(1) 2"-10" 150磅闸阀门盖密封面采用球墨铸铁。
(2) 10"以上闸阀门盖密封面采用球墨铸铁。
(3) 闸阀门盖密封面采用球墨铸铁。

Note:
(1) One Piece Bonnet/Yoke For 2"-12" 150LB Valves.
(2) Thrust Bearing To Be Used For Size Over 10".
(3) Electric Actuator Is Optional For Valves.

尺寸及重量Dimensions and Weights

GO: 齿轮传动Gear Operated

规格 Size	L/L1		L2		H(—)		W	重量Weight Kg(—)	
	RF/BW	mm	RTJ	mm	开OPEN	mm			
2	8.5	216	9.12	232	13	330	9.8	250	30
2.5	9.5	241	10.12	257	14.5	368	9.8	250	36
3	11.12	282	11.74	298	15.5	394	11.8	300	61
4	12	305	12.62	321	18.6	473	11.8	300	77
6	15.88	403	16.5	419	29	711	13.8	350	153
8	16.5	419	17.12	435	32	813	15.7	400	286
10	18	457	18.62	473	39.5	1003	19.7	500	412
12	19.75	502	20.37	517	44.8	1137	23.6	600	576
14	30	762	30.62	778	58.6	1489	23.6	600	886
16	33	838	33.62	854	62.2	1581	GO		1175
18	36	914	36.62	930	79.4	2017	GO		1301
20	39	991	39.75	1010	87.7	2228	GO		1672
24	45	1143	45.88	1165	102.6	2605	GO		2562
26	49	1245	50	1270	106.2	2698	GO		2998
28	53	1346	54	1372	113	2870	GO		3200
30	55	1397	56	1422	118.9	3020	GO		3490
32	60	1524	61.12	1552	129.7	3295	GO		4270
36	68	1727	69.12	1756	139.2	3536	GO		4995

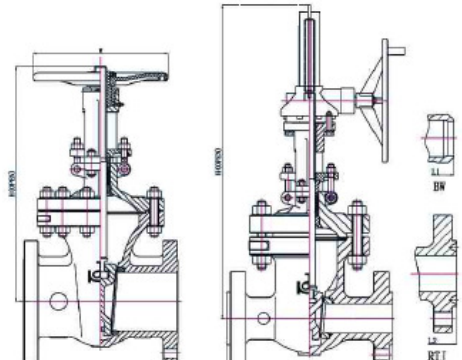

注:
(1) 2"-10" 300磅闸阀门盖密封面采用球墨铸铁。
(2) 10"以上闸阀门盖密封面采用球墨铸铁。
(3) 闸阀门盖密封面采用球墨铸铁。
(4) 闸阀门盖密封面采用球墨铸铁。

Note:
(1) One Piece Bonnet/Yoke For 2"-12" 300 Valves.
(2) Thrust Bearing To Be Used For Size Over 10".
(3) Electric Actuator Is Optional For Valves.
(4) Electric Actuator Is Optional For Valves.



尺寸及重量Dimensions and Weights

GO: 齿轮传动Gear Operated

规格 Size	L/L1		L2		H(=)		W		重量 Weight Kg(≈)
	RF/BW	mm	RTJ	mm	开OPEN	mm	mm	mm	
2	11.5	292	11.62	295	20.1	510	10	254	44
2.5	13	330	13.12	333	21.8	554	10	254	60
3	14	356	14.12	359	23.4	595	12	305	80
4	17	432	17.12	435	28	712	14	356	145
6	22	559	22.12	562	39.2	995	20	508	309
8	26	660	26.12	663	45.6	1157	24	610	522
10	31	787	31.12	790	54.1	1373	27	686	779
12	33	838	33.12	841	63.1	1603	GO		1108
14	35	889	35.12	892	76	1930	GO		1503
16	39	991	39.12	994	80	2032	GO		1939
18	43	1092	43.12	1095	90	2286	GO		2733
20	47	1194	47.25	1200	102.0	2591	GO		3214
24	55	1397	55.38	1407	123.0	3124	GO		4177
26	57	1448	57.5	1461	131.2	3332	GO		5220

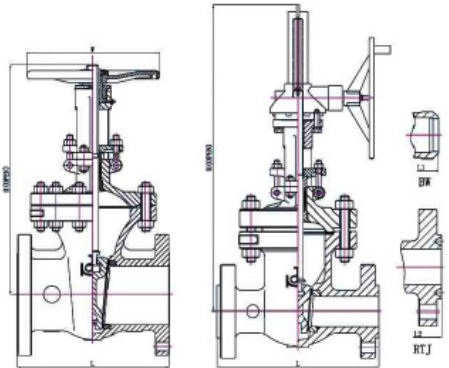

Note:
(1) 2"-6" Class 600 铸钢闸阀结构及重量为参考式。
(2) 以上为闸阀的总重量。
(3) 闸阀的总重量。
(4) 闸阀可选项为电液驱动。

Note:
(1) 2"-6" Class 600 铸钢闸阀结构及重量为参考式。
(2) Thrust Bearing To Be Used For Size Over 6 in.
(3) RTJ is Optional Between Body And Bonnet.
(4) Electric Actuator is Optional For Valve.

尺寸及重量Dimensions and Weights

GO: 齿轮传动Gear Operated

压力等级 Class	规格 Size	In mm	2	2.5	3	4	6	8	10	12	14	16	18	20	
			50	65	80	100	150	200	250	300	350	400	450	500	
900	L/L1	RF/BW	in	14.5	16.5	15	18	24	29	33	38	40.5	44.5	48	52
			mm	368	419	381	457	610	737	838	965	1029	1130	1219	1321
	L2	RTJ	in	14.62	16.62	15.12	18.12	24.12	29.12	33.12	38.12	40.88	44.88	48.5	52.5
			mm	371	422	384	460	613	740	841	968	1038	1140	1232	1334
	H	开 OPEN	in	24.4	27.8	29	32.5	41.9	48	53	72.4	79.7	85.4	87.9	95.9
			mm	620	705	737	825	1065	1219	1345	1840	2025	2170	2232	2435
W		in	11.8	13.8	13.8	15.7	19.7	GO	GO	GO	GO	GO	GO	GO	
		mm	300	350	350	400	500								
重量 Weight	RF	Kg	95	108	125	194	378	635	900	1550	2170	3070	3930	5120	
1500	L/L1	RF/BW	in	14.5	16.5	18.5	21.5	27.75	32.75	39	44.5	49.5	54.5		
			mm	368	419	470	546	706	832	991	1130	1257	1384		
	L2	RTJ	in	14.62	16.62	18.62	21.62	28	33.13	39.38	45.12	50.25	55.38		
			mm	371	422	473	549	711	842	1000	1146	1276	1407		
	H	开 OPEN	in	27.4	27.8	30.3	34.3	43	55.1	63	72.4	89.3	95.3		
			mm	695	705	770	872	1092	1400	1600	1840	2267	2420		
W		in	13.8	15.7	15.7	17.7	23.6								
		mm	350	400	400	500	600								
重量 Weight	RF	Kg	95	128	161	275	627	1180	2200	3300	3693	4890			

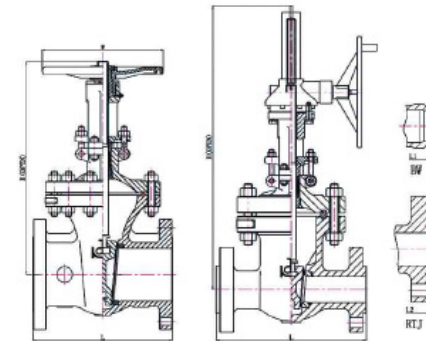

Note:
(1) 2"-6" 900/1500 铸钢闸阀结构及重量为参考式。
(2) 以上为闸阀的总重量。
(3) RTJ is Optional Between Body And Bonnet.
(4) 闸阀可选项为电液驱动。

Note:
(1) 2"-6" 900/1500 铸钢闸阀结构及重量为参考式。
(2) Thrust Bearing To Be Used For Size Over 6 in.
(3) Electric Actuator is Optional For Valve.



设计制造标准

- 设计标准: ASME B16.34 Special Class
- 结构长度: ASME B16.10
- 法兰连接: ASME B16.5
- 焊接连接: ASME B16.25
- 检验与试验标准: API 598

主要结构

- 压力自密封闸阀, 闸杆外螺纹和支架, 升降闸杆, 手轮不升降, 弹性闸板(或双闸板), 密封面堆焊硬质合金的焊接闸板

Design and Fabrication Specifications

- Design Specification: ASME B16.34 Special Class
- Face to Face (End to End): ASME B16.10
- End Flange: ASME B16.5
- BW End: ASME B16.25
- Inspection & Testing: API 598

Main Construction

- Pressure Seal Bonnet, OS&Y, Rising Stem, Non-rising Handwheel, Flexible Wedge(Or Double Disc), Stellite Welded Stem Ring

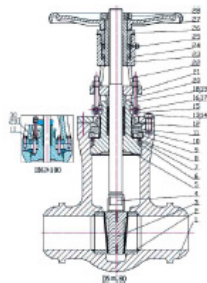

No.	Name	名称	Material List 材料表-英标		
			-29 - 425°C	-29 - 540°C	-29 - 570°C
1	Body	闸体	A216 WCB	A217 WC6	A217 WC9
2	Seat Ring	闸座	A105	A182 F11	A182 F22
3	Wedge	闸板密封面	A216 WCB	A217 WC6	A217 WC9
4	Stem	闸杆	A182 F6a	Cr. Mo. V钢Cr. Mo. V steel	
5	Bonnet	闸盖	A105	A182 F11	A182 F22
6	Seal Ring	密封圈	316-柔性石墨或特制316-Graphite or SPL		
7	Holding Ring	垫圈	304	Cr. Mo. V钢Cr. Mo. V steel	
8	Gland Ring	填料环	F6a	Cr. Mo. V钢Cr. Mo. V steel	
9	Locking Ring	四开环	38CrMoAl	Cr. Mo. V钢Cr. Mo. V steel	
10	Cover	吊盖	45	Cr. Mo. V钢Cr. Mo. V steel	
11	Packing Ring	填料	石墨或特制Graphite or SPL		
12	Jacking Nut	阳螺母	45	Cr. Mo. V钢Cr. Mo. V steel	
13	Bolt	支架螺栓	A193 B7	A193 B16	
14	Nut	支架螺母	A194 2H	A194 7	
15	Bonnet Clamp	夹板	35		
16	Bolt	螺栓	A193 B7	A193 B7	
17	Nut	螺母	A194 2H	A194 2H	
18	Eye Bolt	吊钩螺栓	A193 B7	A193 B7	
19	Eye Bolt Nut	吊钩螺栓螺母	A194 2H	A194 2H	
20	Gland	填料压套	A182 F6a	A182 F6a	
21	Gland Flange	填料压板	A216 WCB	A217 WC6	A217 WC9
22	Yoke	支架	A216 WCB		A217 WC9
23	Stem Nut	闸杆螺母	ZCuAl10Fe3, A139 D2		
24	Thrust Bearing	推力轴承	GCr15		
25	Grease Nipple	油嘴	35		
26	Retaining Nut	压盖螺母	35		
27	Handwheel	手轮	QT400		
28	Handwheel Nut	手轮螺母	35		
29	Bolt	吊盖螺栓	A193 B7	A193 B7	
30	Nut	吊盖螺母	A194 2H	A194 2H	

※ 可选项 RTJ, RTJ 等。

Note: RTJ and RW are available.

尺寸及重量Dimensions and Weights

GO: 齿轮传动Gear Operated

压力等级 Class	规格 Size	In mm	2	2.5	3	4	6	8	10	12	14	16	
			50	65	80	100	150	200	250	300	350	400	
900	L1	BW	in	8.5	10	12	14	20	26	31	36	39	43
			mm	216	254	305	356	508	660	787	914	991	1092
	H	开 OPEN	in	20.1	24.1	25.5	38.8	44.8	54.4	61.6	65.2	79.1	83.8
			mm	510	613	648	989	1138	1382	1565	1655	2008	2129
	W		in	12.6	13.4	15.7	17.7	GO	GO	GO	GO	GO	GO
			mm	320	340	400	450						
重量 Weight	RF	Kg	72	107	137	229	383	749	1451	1720	2518	2818	
1500	L1	BW	in	8.5	10	12	16	22	28	34	39	42	47
			mm	216	254	305	406	559	711	864	991	1067	1194
	H	开 OPEN	in	20.1	24.1	25.5	38.8	44.8	54.4	61.6	65.2	79.1	83.8
			mm	510	613	648	989	1138	1382	1565	1655	2008	2129
	W		in	12.6	13.4	15.7	GO	GO	GO	GO	GO	GO	GO
			mm	320	340	400							
重量 Weight	RF	Kg	75	110	151	252	421	824	1596	1892	2770	3099	
2500	L1	BW	in	11	13	14.5	18	24	30	36			
			mm	279	330	368	457	610	762	914			
	H	开 OPEN	in	20.7	24.8	38.5	39.7	45.6	55.6	628			
			mm	525	610	978	1009	1158	1412	1595			
	W		in	12.6	15.4	GO	GO	GO	GO	GO			
			mm	320	390								
重量 Weight	RF	Kg	101	110	192	321	536	1049	2031				

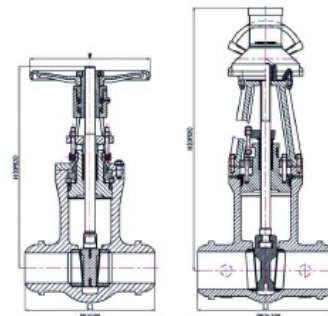

Note:
(1) 可选项 RTJ 及 RTJ。
(2) 闸杆可选项为电液驱动。

Note:
(1) 可选项 RTJ 及 RTJ。
(2) Thrust Bearing To Be Used With Flange.
(3) Electric Actuator is Optional For Valve.

设计制造标准

- 设计标准: GB/T 12234, GB/T 12224
- 结构长度: GB/T 12221
- 法兰连接: GB/T 9113, JB/T79
- 焊接连接: GB/T 12224
- 检验与试验标准: JB/T8092

注
★如需可满足SY/T 0599要求

主要结构

- 明杆外螺纹和支架、升降杆、弹性闸板、栓接阀盖、焊接闸座
- 推力轴承及分离式阀盖/支架用于大口径阀门

Design and Fabrication Specifications

- Design Specification: GB/T 12234, GB/T 12224
- Face to Face (End to End): GB/T 12221
- End Flange: GB/T 9113, JB/T79
- BW End: GB/T 12224
- Inspection & Testing: JB/T8092

Note:

★Meet SY/T 0599 on Request

Main Construction

- OS&Y, Rising Stem, Flexible Wedge, Bolted Bonnet, Welded Seal Ring
- Thrust Bearing and Separated Bonnet/Yoke Used for Larger Size Valve

No.	Name	名称	Material List	材料表-英标
1	Body	阀体	WCB	LCB WCB CF8
2	Seat Ring	阀座密封面	A105	LF2 F11 304
3	Wedge	闸板	WCB	LCB WCB CF8
4	Stem	闸杆	Cr13, F304, F316	F304 F316
5	Gasket	垫片	304/316+柔性石墨304/316+Graphite	316+柔性石墨316+Graphite
6	Bonnet Bolt	中法兰螺栓	A193 B7 A320 L7	A193 B8
7	Bonnet Bolt Nut	中法兰螺母	A194 2H A194 4 A194 7	A194 8
8	Bonnet	阀盖	WCB	LCB WCB CF8
9	Backseat	上密封座	Cr13, 304, 316	304 316
10	Packing	填料	编织石墨+柔性石墨Braided Graphite+Die Formed Graphite Rings	304 316
11	Eye Bolt Pin	销	35	12Cr13
12	Gland Eye Bolt	冠节螺栓	35CrMoA A320 L7	A193 B8
13	Eye Bolt Nut	冠节螺栓螺母	45 A194 4 A194 7	A194 8
14	Gland	填料压盖	Cr13, 304, 316	304 316
15	Yoke Bolt(1)	支架螺栓(1)	35CrMo A320 L7	A193 B8
16	Yoke Bolt Nut(1)	支架螺母(1)	45 A194 4 A194 7	A194 8
17	Gland Flange	填料压板	WCB	LCB WCB CF8
18	Yoke(1)	支架(1)	WCB	LCB WCB CF8
19	Stem Nut	闸杆螺母	ZCuAl10Fe3, A439 D2	
20	Grease Nipple	油嘴	35	SS-不锈钢
21	Retaining Nut	压盖螺母	35	SS-不锈钢
22	Handwheel	手轮	QT400	
23	Handwheel Nut	手轮螺母	35	SS-不锈钢
24	Lantern Ring (2)	引盖环(2)	Cr13, 304, 316	304 316
25	Plug (2)	螺塞(2)	CS碳钢	SS-不锈钢 304 316

注: (1)适用于阀盖和阀体分开的阀门, (2)可选。

Note: (1) Suitable for valves with separated bonnet and yoke, (2) Optional.

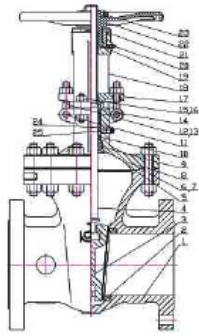

尺寸及重量Dimensions and Weights

GO: 齿轮传动Gear Operated

公称压力 PN	公称口径 DN	mm	50	65	80	100	150	200	250	300	350	400	450	500	600
1.6MPa	L	mm	250	270	280	300	350	400	450	500	550	600	650	700	800
	H _{max}	mm	411	428	486	565	773	955	1160	1375	1512	1750	1960	2575	2990
	W	mm	180	240	250	250	300	350	400	450	500	600	650	720	800
2.5MPa	L	mm	250	270	280	300	350	400	450	500	550	600	650	700	800
	H _{max}	mm	411	428	486	565	773	955	1160	1375	1512	1750	1960	2575	2990
	W	mm	180	240	250	250	300	350	400	450	500	600	650	720	800
4.0MPa	L	mm	250	280	310	350	450	550	650	750	850	950	1150	1350	
	H _{max}	mm	440	473	552	671	883	1086	1298	1535	1678	1903	2423	2810	
	W	mm	280	280	300	300	350	450	560	600	650	720	GO	GO	
6.4MPa	L	mm	250	280	310	350	450	550	650	750	850	950	1150	1350	
	H _{max}	mm	448	475	553	679	893	1100	1332	1535	1678	1903	2423	2810	
	W	mm	280	280	320	360	450	550	650	650	720	720	GO	GO	
10.0MPa	L	mm	360	400	400	400	450	550	650	650	750	850	950	1150	1350
	H _{max}	mm	558	622	671	710	972	1100	1305	1536	1690	1910	2200	2820	
	W	mm	360	400	400	400	450	550	650	650	750	850	950	1150	1350

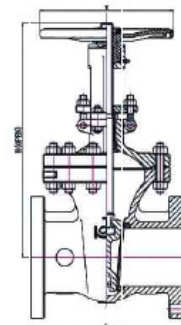

注: (1) 适用于不带电动装置。

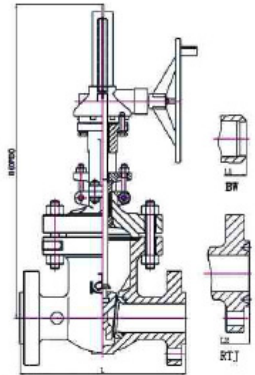

Note: (1) Electric Actuator is Optional For Valve.

设计制造标准

- 设计标准: API 600, ASME B16.34
- 结构长度: ASME B16.10
- 法兰连接: ASME B16.5
- 检验与试验标准: API 598

注
★可提供焊接阀盖

主要结构

- 非升降闸杆、栓接阀盖、弹性闸板。

Design and Fabrication Specifications

- Design Specification: API 600, ASME B16.34
- Face to Face (End to End): ASME B16.10
- End Flange: ASME B16.5
- Inspection & Testing: API 598

Note:

★Welded Seat Ring is available.

Main Construction

- Non-Rising Stem, Bolted Bonnet, Flexible Wedge.

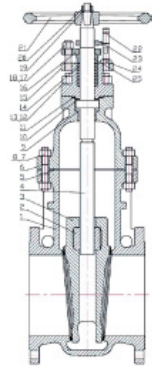

尺寸及重量Dimensions and Weights

GO: 齿轮传动Gear Operated

规格 Size	L		H(≈)		W		重量Weight RF(≈)
	in	mm	in	mm	in	mm	
2	7	178	17.9	455	7.9	200	22
3	8	203	17	432	9.84	250	43
4	9	229	19.1	484	11.8	300	56.5
6	10.5	267	23.3	592	13.8	350	92
8	11.5	292	29.7	756	13.8	350	164
10	13	330	33.7	856	15.8	400	235
12	14	356	42.2	1072	17.7	45	375
16	16	406	49.21	1250	19.69	500	660
20	18	457					
24	20	508					
28	24	610					
30	24	610					
32"	28.35	720	91.5	2324			2873
36	28	711					
40"	33.07	840	102.17	2595			4165

注: (1) 适用于闸杆长度在600mm以内。

Note: (1) Pressure Class of 32" and 42" are 150 Lb.

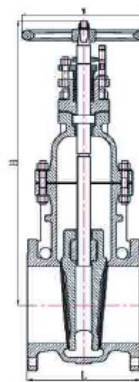

注: (1) 适用于闸杆长度在600mm以内, (2) 适用于带电动装置。

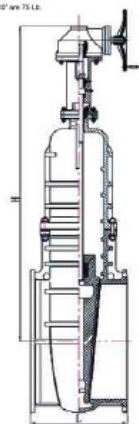

Note: (1) Thrust Bearing To Be Used For Size Over 10 In, (2) Electric Actuator is Optional For Valve.

No.	Name	名称	Material List	材料表-英标
1	Body	阀体	A216 WCB	
2	Seat Surface	阀座密封面	13Cr, STL	
3	Stem Nut	闸杆螺母	ZCuAl10Fe3, A439 D2	
4	Wedge	闸板	A216 WCB	
5	Wedge Surface	闸板密封面	13Cr, STL	
6	Stem	闸杆	A182 F8a	
7	Gasket	垫片	不锈钢+柔性石墨SS+Graphite	
8	Bonnet	阀盖	A216 WCB	
9	Bolt	螺栓	A193 B7	
10	Nut	螺母	A194 2H	
11	Bush	衬套	QA110-3-1.5	
12	Thrust Washer	止推垫	QA110-3-1.5	
13	Gasket	垫片	不锈钢+柔性石墨SS+Graphite	
14	Bolt	螺栓	A193 B7	
15	Nut	螺母	A194 2H	
16	Packing Ring	填料	柔性石墨Graphite	
17	Stuffing Box	填料箱	A216 WCB	
18	Gland Flange	填料压板	A216 WCB	
19	Bolt	螺栓	A193 B7	
20	Nut	螺母	A194 2H	
21	Washer	垫圈	Q235-A	
22	Nut	螺母	35	
23	Handwheel	手轮		
24	Indicate Pole	指示杆	CS碳钢	
25	Indicator	指针	CS碳钢	
26	Nut	螺母	35	
27	Gland	填料压盖	Cr13	



铸钢截止阀 Cast Steel Globe Valve

设计制造标准

- 设计标准: BS1873, ASME B16.34
- 结构长度: ASME B16.10
- 法兰连接: ASME B16.5
- 焊接连接: ASME B16.25
- 检验与试验标准: API 598

注

*如需要可满足NACE MR-0175要求

主要结构

- 明杆外螺纹和支架、升降阀杆、锥盖式阀瓣、栓接阀盖
- 带推力轴承和平盘式阀瓣结构用于大口径阀门

Design and Fabrication Specifications

- Design Specification: BS1873, ASME B16.34
- Face to Face (End to End): ASME B16.10
- End Flange: ASME B16.5
- BW End: ASME B16.25
- Inspection & Testing: API 598

Notes:

*Meet NACE MR-0175 on Request

Main Construction

- OS&Y, Rising Stem, Plug Type Disc, Bolted Bonnet
- Thrust Bearing and Balanced Disc Construction Used for Larger Size Valve

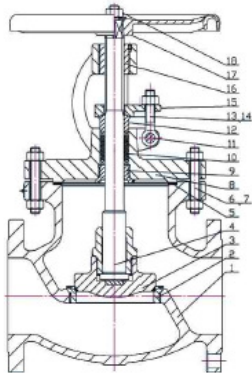

材料表 Material List

No.	Name	名称	Material List 材料表-美标					
1	Body	阀体	A216 WCB	A352 LCB	A217 WC6	A351 CF8	A351 CF8M	
2	Seat Ring	阀座	A105	A350 LF2	A182 F11	A182 F304	A182 F316	
	Seat Surface	阀座密封面	13Cr, 304, 316, STL	STL	304, STL	316, STL		
3	Disc	阀瓣	A216 WCB	A352 LCB	A217 WC6	A351 CF8	A351 CF8M	
	Disc Surface	阀瓣密封面	13Cr, 304, 316, STL	STL	304, STL	316, STL		
4	Stem	阀杆	A182 F6a, F304, F316		A182 F304	A182 F316		
5	Gasket	垫片	304/316+柔性石墨304/316+Graphite		316+柔性石墨316+Graphite			
6	Ring for RTJ	金属环	304/316					
7	Bonnet Bolt	中法兰螺栓	A193 B7	A320 L7	A193 B16	A193 B8		
8	Bonnet Nut	中法兰螺母	A194 2H	A194 4	A194 7	A194 8		
9	Bonnet	阀盖	A216 WCB	A352 LCB	A217 WC6	A351 CF8	A351 CF8M	
10	Backseat	上密封座	410, F304, F316		304	316		
11	Packing	填料	编织石墨-柔性石墨 Braided Graphite + Die Formed Graphite Rings					
12	Eye Bolt Pin	销	35					
13	Gland	填料压套	A182 F6a, F304, F316		A182 F304	A182 F316		
14	Gland Eye Bolt	活节螺栓	A193 B7	A320 L7	A193 B16	A193 B8		
15	Eye Bolt Nut	活节螺栓螺母	A194 2H	A194 4	A194 7	A194 8		
16	Gland Flange	填料压板	A216 WCB	A352 LCB	A217 WC6	A351 CF8	A351 CF8M	
17	Stem Nut	阀杆螺母	ZCuAl10Fe3, A439 D2					
18	Handwheel	手轮	QT400					
19	Handwheel Nut	手轮螺母	35					
								SS-不锈钢

铸钢截止阀

Cast Steel Globe Valve ---class 150/300/600



铸钢截止阀

Cast Steel Globe Valve ---Class 900/1500

尺寸及重量 Dimensions and Weights

GO: 齿轮传动 Gear Operated

Class	规格	Size	in	2	2.5	3	4	6	8	10	12	14	16	
150	L/L1	RF/BW	in	8	8.5	9.5	11.5	16	19.5	24.5	27.5	31	36	
			mm	203	216	241	292	406	495	622	699	787	914	
	L2	RTJ	in	8.5	9	10	12	16.5	20	25	28	31.5	36.5	
			mm	216	229	254	305	419	508	635	711	800	927	
	H	开OPEN	in	11.8	13.4	14.2	16.5	19.7	23.2	28	31.9	34.6	37	
			mm	300	340	360	420	500	590	710	810	880	940	
W	GO	in	7.9	8.7	9.4	11	15.7	17.7	19.7	21.7	23.7	25.7		
		mm	200	220	240	280	400	450	500	550	550	550		
	重量Weight	RF	Kg	18	26	32	50	87	142	250	355	430	490	
300	L/L1	RF/BW	in	10.5	11.5	12.5	14	17.5	22	24.5	28			
			mm	267	292	318	356	445	559	622	711			
	L2	RTJ	in	11.12	12.12	13.12	14.62	18.12	22.62	25.12	28.62			
			mm	282	308	333	371	460	575	638	727			
	H	开OPEN	in	13	14.2	15.7	17.7	21.3	26.4	30.3	33.7			
			mm	330	360	400	450	540	670	770	855			
W	GO	in	9.4	9.4	11	12.6	17.7	19.7	GO	GO				
		mm	240	240	280	320	450	500						
	重量Weight	RF	Kg	25	40	50	70	152	220	390	517			
600	L/L1	RF/BW	in	11.5	13	14	17	22	26	31				
			mm	292	330	356	432	559	660	787				
	L2	RTJ	in	11.62	13.12	14.12	17.12	22.12	26.12	31.12				
			mm	295	333	359	435	562	663	790				
	H	开OPEN	in	14.2	15.7	17.3	19.7	28.3	31.5	34.3				
			mm	360	400	440	500	720	800	870				
W	GO	in	11	11.8	13.8	15.7	19.7	19.7	GO	GO				
		mm	280	300	350	400	500							
	重量Weight	RF	Kg	36	48	59	105	237	428	740				

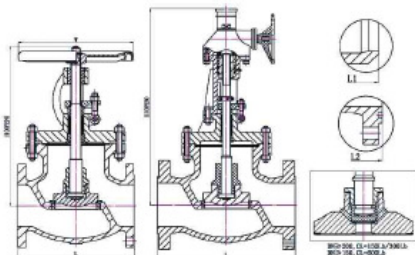

尺寸及重量 Dimensions and Weights

GO: 齿轮传动 Gear Operated

Class	规格	Size	in	2	2.5	3	4	6	8	10
900	L/L1	RF/BW	in	14.5	16.5	15	18	24	29	33
			mm	368	419	381	457	610	737	838
	L2	RTJ	in	14.62	16.62	15.12	18.12	24.12	29.12	33.12
			mm	371	422	384	460	613	740	841
	H	开OPEN	in	23.6	26	26.2	31.5	43.6	46.6	50.3
			mm	600	660	665	800	1108	1184	1278
W	GO	in	13.8	13.8	17.7	19.7	GO	GO	GO	
		mm	350	350	450	500				
	重量Weight	RF	Kg	95	138	122	195	435	730	1231
1500	L/L1	RF/BW	in	14.5	16.5	18.5	21.5	27.75	32.75	39
			mm	368	419	470	546	705	832	991
	L2	RTJ	in	14.62	16.62	18.62	21.62	28	33.13	39.1
			mm	371	422	473	549	711	842	994
	H	开OPEN	in	26	26	30.3	33.5	45.1	52.9	65
			mm	660	660	770	850	1145	1345	1651
W	GO	in	13.8	13.8	19.7	GO	GO	GO	GO	
		mm	350	350	500					
	重量Weight	RF	Kg	95	138	250	435	540	970	1520

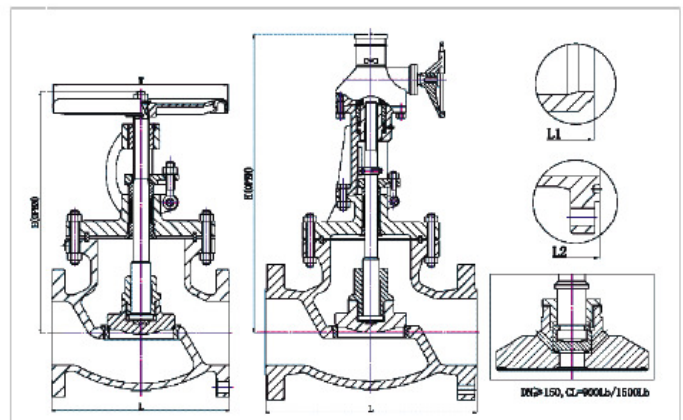

设计制造标准

- 设计标准: GB/T 12235, GB/T 12224
- 结构长度: GB/T12221
- 法兰连接: GB/T 9113, JB/T79
- 焊接连接: GB/T12224
- 检验与试验标准: JB/T9092

注
* 如需要可满足SY/T 0599要求

主要结构

- 明杆外螺纹和支架、升降杆、平衡器、检修装置
- 带推力轴承和平式阀瓣结构用于大口径阀门

Design and Fabrication Specifications

- Design Specification: GB/T 12235, GB/T 12224
- Face to Face (End to End): GB/T12221
- End Flange: GB/T 9113, JB/T79
- BW End: GB/T12224
- Inspection & Testing: JB/T9092

Note:
* Meet SY/T 0599 on Request

Main Construction

- OS&Y, Rising Stem, Flat seat Type Disc, Bolted Bonnet
- Thrust Bearing and Balanced Disc Construction Used for Larger Size Valve

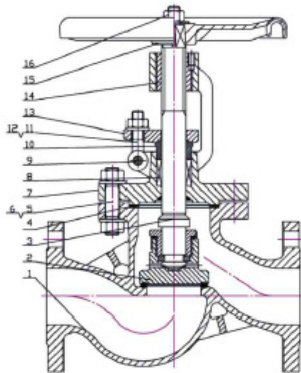

材料表 Material List

No.	Name	名称	Material List 材料表-美标				
1	Body	阀体	WCB	LCB	WC6	CF8	CF8M
	Seat Surface	阀座密封面	13Cr, 304, 316, STL	STL	304, STL	316, STL	
2	Disc	阀瓣	WCB	LCB	WC6	CF8	CF8M
	Disc Surface	阀瓣密封面	13Cr, 304, 316, STL	STL	304, STL	316, STL	
3	Stem	阀杆	F6a, F304, F316		F304, F316		
4	Gasket	垫片	304/316+柔性石墨304/316+Graphite		316+柔性石墨316+Graphite		
5	Bonnet Bolt	中法兰螺栓	35CrMoA	A320 L7	A193 B16	A193 B8	
6	Bonnet Bolt Nut	中法兰螺母	45	A194 4	A194 7	A194 8	
7	Bonnet	阀盖	WCB	LCB	WC6	CF8	CF8M
8	Packing	填料	编织石墨+柔性石墨/Braided Graphite +Die Formed Graphite Rings				
9	Eye Bolt Pin	销	35				
10	Gland	填料压套	12Cr13, 304, 316	304 316			
11	Gland Eye Bolt	活节螺栓	35CrMoA	A193 B16	A193 B16	A193 B8	
12	Eye Bolt Nut	活节螺栓螺母	45	A194 7	A194 7	A194 8	
13	Gland Flange	填料压板	WCB	LCB	WC6	CF8	CF8M
14	Stem Nut	阀杆螺母	ZCuAl10Fe3, A439 D2				
15	Handwheel	手轮	QT400				
16	Handwheel Nut	手轮螺母	CS碳钢		SS不锈钢		

尺寸及重量Dimensions and Weights

GO: 齿轮传动Gear Operated

公称压力 PN	公称直径 DN(mm)	15	20	25	32	40	50	65	80	100	150	200	250	300	350	400
1.6MPa	L mm	130	150	160	180	200	230	290	310	350	480	600	730	850	980	1100
	H mm	218	258	275	280	330	350	380	400	415	510	710	786	925		
	W mm	120	140	160	180	200	240	280	280	320	400	400	450	500	GO	GO
	Wt Kg	4.8	6.5	7	8.5	11	14.5	21.5	27	30	91	148	405	610		
2.5MPa	L mm	130	150	160	180	200	230	290	310	350	480	600	730	850	980	1100
	H mm	218	258	275	280	330	350	400	400	415	510	710	786	925		
	W mm	120	140	160	180	200	240	280	280	320	400	400	450	500	GO	GO
	Wt Kg	5	6.9	7.4	8.5	12.5	16	25	30	34.5	98	170	446	654		
4.0MPa	L mm	130	150	160	180	200	230	290	310	350	480	600	730	850	980	1100
	H mm	233	275	285	302	355	373	408	436	480	611	720				
	W mm	120	140	160	180	200	240	280	320	360	400	400	GO	GO	GO	
	Wt Kg	5.2	7	8.7	9	12	24	33	44	60	98	170				
6.4MPa	L mm	170	190	210	230	260	300	340	380	430	550	650	775	900		
	H mm	195	228	275	325	360	410	450	485	537	646	813				
	W mm	140	160	180	200	240	280	320	360	400	450	500	GO	GO		
	Wt Kg	5.5	7.5	9.1	12	18	26	36	48	68	107	182				
10.0MPa	L mm	170	190	210	230	260	300	340	380	430	550	650	775	900		
	H mm	223	275	285	302	326	365	427	460	528	619	925				
	W mm	140	160	180	220	240	280	320	400	450	500	GO	GO			
	Wt Kg	11	13	14	15	29	49	65	95	115	235	352				

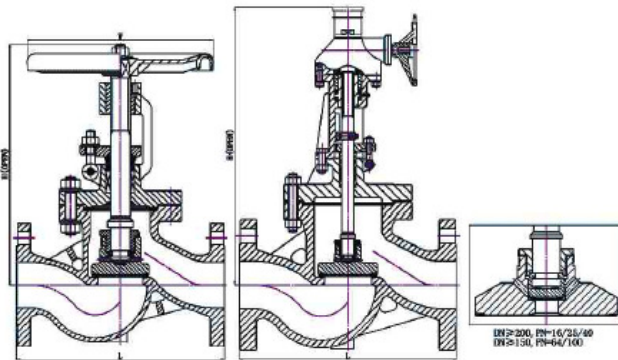

400000系列控制阀
400000 SERIES CONTROL VALVE

概述 General Description

87/88-400000系列气动单座控制阀是由400000系列单座阀和87/88型气动薄膜多弹簧执行机构组成。400000系列单座阀在消化吸收国外先进技术的基础上开发的产品。该系列产品具有流通能力大、泄漏量小、可调比大和抗振性好等特点，且与气动薄膜多弹簧执行机构匹配后，整机体积小、重量轻。

87/88-400000系列气动单座控制阀通用性好，可适用于各种中、低压流体的过程控制。

The 87/88-400000 series pneumatic single-seat control valve consists of a 400000 series single-seat valve and a 87/88 pneumatic diaphragm actuator with multi-springs. The 400000 series single-seat valve is a newly-launched product based upon the digestion of foreign and domestic advanced technology. It features big flow, Capacity little leakage, great rangeability and excellent anti-vibration. Fitted with pneumatic diaphragm actuator with multi-springs, the complete unit has a compact structure and light weight.

The 87/88-400000 series pneumatic single-seat control valve is a general purpose valve, suitable for process control of medium and low pressure fluid.



型号编制说明 Explanation of the Model Number

X	X	X	X	X	X	X
执行机构 Actuator	阀系列 Valve series	密封类型 Seal type	流量特性 Flow charo- teristics	结构型式 Configuration type	填料 Packing	阀盖形式 Bonnet form
87多弹簧正 87 Multi- spring positive	4单座阀 Single seat	1硬密封 Metal to metal contact	5不定型 Undefined	1标准 Standard	1单圈密封 Single packing	1低温 Cryogenic
88多弹簧反 88 Multi- spring reverse		2软密封 Soft seal	1线性 Linear	2降噪型 Low noise	2双圈密封 Double packing	2标准 Standard
ZDL电动 ZDL Electric			2等百分比 Equal percentage	2带液腔 Anti- cavitation	2波纹管 Bellows sealed	3延长型 Extended
SD手动 SD Manual						4冷却型 Cooling fn
37正作用 37 Positive action						
38反作用 38 Reverse action						

规格 Specifications

- 公称直径 (Nominal Diameter): DN20, 25, 40, 50, 65, 80, 100, 150, 200 3/4", 1", 1-1/2", 2", 2-1/2", 3", 4", 6", 8"
- 压力等级 (Pressure Class): PN16, 25, 40, 64, 100, 160, 250, ANSI CLASS 150, 300, 600, 900, 1500
- 温度范围 (Temperature Range): -195~+450℃
- 连接形式 (Connection): RF和RTJ法兰式 (RF Flange and RTJ flange), 对焊和承插焊式 (BW ends and SW ends).



主要技术参数 Primary Technical Data

序号NO.	项目Item	技术指标 (带阀门定位器) Technical Data(with Positioner)
1	基本误差 (%) Intrinsic Error	±1.5%
2	回差 (%) Hysteresis	1%
3	死区(%) Dead Band	0.6%
4	阀座泄漏等级 Seat Leakage Class	Class IV
		Class V
		As Per ANSI B 16.104
		Class VI

额定流量系数 Rated Flow Coefficient

直线特性 Linear Characteristics

口径 Bore Diameter	行程 Stroke	阀座直径 (mm)																
		10	12	15	20	25	32	40	50	65	80	100	125	150	200			
3/4(20)	16	额定Cv rated Cv																
1 (25)	16	0.03-0.06:0.1	2.1	3.3	5.1	8												
1 1/2(40)	25																	
2 (50)	25																	
2 1/2(65)	40																	
3 (80)	40																	
4 (100)	40																	
6 (150)	60																	
8 (200)	60																	

等百分比特性 Equal Percentage Characteristics

口径 Bore Diameter	行程 Stroke	阀座直径 (mm)															
		10	12	15	20	25	32	40	50	65	80	100	125	150	200		
3/4(20)	16	1.9	2.9	4.7	7.3												
1 (25)	16																
1 1/2(40)	25																
2 (50)	25																
2 1/2(65)	40																
3 (80)	40																
4 (100)	40																
6 (150)	60																
8 (200)	60																

固有流量特性 Inherent Flow Characteristics

- 标准阀内件有二种固有流量特性
- 直线特性和等百分比特性。
- 特性曲线见图2。
- 固有可调比R: 50; 1
- Standard valve trim has two (2) kinds of inherent flow characteristics
- i.e. linear characteristics and equal percentage characteristics.
- For characteristics curves, please see Fig. 2.
- Cv ratio: 50: 1

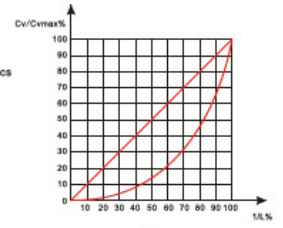

控制阀结构图 Configuration Drawing of the Control Valve



图3

主要零件材料 Material Used for Major Parts

序号NO.	零件名称 Part Name	材料 Material
1	阀体 Body	WCB, LCB, WC6, CF8, CF8M
2	阀盖 Bonnet	WCB, LCB, A105, F11, CF8, CF8M
3	阀杆 Stem	12Cr13, 05Cr17Ni4Cu4Nb, 06Cr19Ni10
4	阀瓣 Primary plug	12Cr13, 17-4PH, Stellite F304, Stellite F316
5	阀座 Seat	F304, F316, 堆焊Stellite No. 6, 12Cr13
6	填料 Packing	PTFE, 柔性石墨 (Flexible graphite)

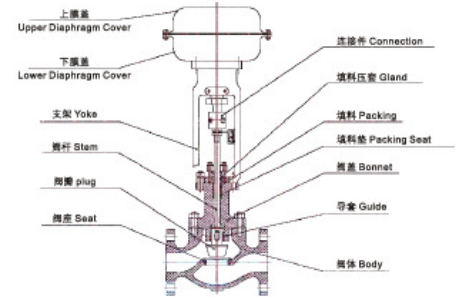

外形尺寸 Overall Dimensions

外形尺寸见图4及下表
For overall dimensions, please see Fig. 4 and the following table:

公称直径 Bore Diameter DN		L(mm)				A(mm)	H(mm)		H ₁ (mm)		
英寸 Inch	mm	Class 150 PN16	Class 300 PN40	Class 600 PN100	焊接式 Welded end		标准型 阀盖 Standard Bonnet	延长型 阀盖 Extended Bonnet	Class 150 PN16	Class 300 PN40	Class 600 PN100
3/4	20	184	194	206	210	285	398	548	52	52	52
1	25	184	197	210	210		410	560	52	52	52
1 1/2	40	222	235	251	251	360	455	620	55	58	60
2	50	254	267	286	286		457	627	60	60	65
2 1/2	65	276	292	311	311	470	610	790	71	73	77
3	80	298	317	337	337		622	807	85	87	90
4	100	352	368	394	394	640	850	105	107	110	
6	150	451	473	508	508	870	1130	140	142	145	
8	200	600	600	610	610	890	1150	178	180	182	

压力等级 Pressure Class: 150-600



图4

概述 General Description

800000系列气动式控制阀是在消化吸收国外先进技术的基础上开发的产品。37/38-800000系列产品由37/38型气动薄膜执行机构和800000系列笼罩式调节器两部分组合而成。37/38型薄膜执行机构推力大，动作稳定可靠。800000系列笼罩式阀瓣吸收了国外先进的低噪音、抗气蚀技术，采用小孔多级降压技术，使该阀具有稳定性好、噪音低、承压比差高，能适应大型电厂、石化等各种工况的调节场合。

800000 series pneumatic cage guided control valve is a newly-launched product based upon the digestion of internationally advanced technology. It consists of two parts, i.e. a 37/38-800000 pneumatic diaphragm actuator and a 800000 series cage guided control valve. 37/38 diaphragm actuator has great thrust force with stable and reliable movement. Adopting internationally advanced technology of low noise, anti-cavitation and small-hole, multi-stage of pressure reduction, 800000 series cage guided control valve features good reliability, low noise, high differential pressure, suitable for applications in such services as large sized power plant and petrochemical plant.

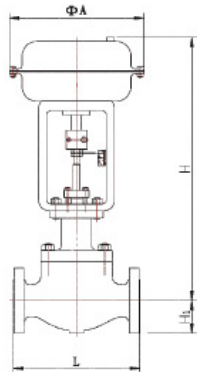

型号编制说明 Explanation of the Model Number

执行机构 Actuator	阀系列 Valve series	密封类型 Seal type	流量特性 Flow characteristics	结构类型 Configuration type	噪音等级 Noise level	阀盖形式 Bonnet form
37正作用 37 Positive action	笼罩式 Cage type valve	1.不平衡 Unbalanced	0.非线性 Unifield	1.标准 Standard	1.标准 Standard	1.标准 Standard
38反作用 38 Reverse action		2.密封环 Seal ring	1.线性 Linear	2.二级 Two stages	2.低噪音 Low noise	2.标准 Standard
ZDL 电液 ZDL Electro-c		3.先导式 Pilot	2.等百分比 Equal percentage	3.三级 Three stages		3.延长型 Extended
48气缸式 48 Cylinder				4.四级 Four stages		4.冷却型 Cooling In
SD 手液 SD Manual						

规格 Specifications

- 公称直径 (Nominal Diameter): DN25, 40, 50, 80, 100, 150, 200, 250 1", 1-1/2", 2", 3", 4", 6", 8", 10"
- 压力等级 (Pressure Class): PN 16, 25, 40, 64, 100, 160, 250 ANSI CLASS 150, 300, 600, 900, 1500
- 温度范围 (Temperature Range): -195 ~ +450°C
- 连接形式 (Connection): RF和RT法兰式 (RF Flange and RTJ flange), 对接焊和承插焊式 (BW ends and SW ends)



主要特点 Primary Features

- 阀芯采用平衡式结构, 允许压差大。
- 阀芯在气缸内壁运动, 导向面积大, 抗振性和耐磨性好。
- 在结构上将密封面和节流面分开, 使介质流动时对密封面的冲刷减少, 从而提高了使用寿命。
- 由于在阀芯和阀座上采用小孔多级减压结构, 可有效减少气蚀和噪音, 适合各种高压差场合。
- 适应性强只需要调整流量就能满足不同流量系数和不同流量特性的要求。
- 采用主副阀芯结构, 可达到严密切断。
- 易于拆卸、检修和维修。

主要技术参数 Primary Technical Data

序号NO.	项目 Item	技术指标 (带阀门定位器) Technical Data(with Positioner)
1	基本误差 (%) Intrinsic Error	±1.5%
2	回差 (%) Hysteresis	1.5%
3	死区 (%) Dead Band	0.6%
4	阀座泄漏等级 Seat Leakage Class	Class II
	As Per ANSI B16.104	Class IV
		Class V

额定流量系数 Rated Flow Coefficient

压力等级 Pressure Class: 150-600

口径 Bore Diameter Inch	行程 Stroke (mm)	额定Cv额定 Cv			
		标准流量 Standard Cage		低噪音、抗气蚀 Low Noise, anti-cavitation	
		线性 Linear	等百分比 Equal percentage	线性 Linear	等百分比 Equal percentage
1	25	25	25	12	21
1½	25	30	30	12	21
2	25	56	56	17	29
3	31.5	115	84	115	90
4	41	212	156	217	170
6	61	468	356	390	360
8	80.5	850	605	890	680
10	100.5	1300	920	1360	1030

压力等级 Pressure Class: 900-1500

口径 Bore Diameter Inch	行程 Stroke (mm)	额定Cv额定 Cv			
		标准流量 Standard Cage		低噪音、抗气蚀 Low Noise, anti-cavitation	
		线性 Linear	等百分比 Equal percentage	线性 Linear	等百分比 Equal percentage
1	25	22.5	22.5	10.8	18
1½	25	27	27	11	19
2	25	50	50	15	26
3	31.5	103	75	100	80
4	41	190	140	195	150
6	61	420	320	350	324
8	80.5	760	540	800	610
10	100.5	1170	820	1220	920

控制阀结构图 Configuration Drawing of the Control Valve

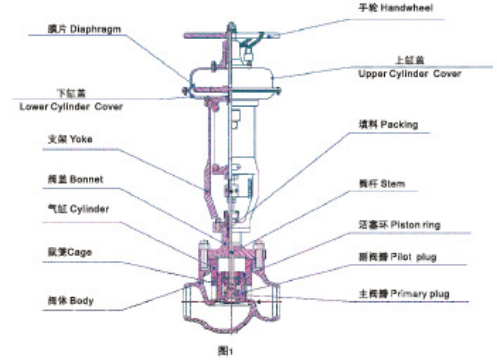

主要零件材料 Material Used for Major Parts

序号NO.	零件名称 Part Name	材料 Material
1	阀体 Body	WCB, LCB, WC6, CF8, CF8M
2	阀盖 Bonnet	WCB, LCB, A105, F11, CF8, CF8M
3	阀杆 Stem	12Cr13, 05Cr17Ni4Cu4Nb, 06Cr19Ni10
4	主副阀 Primary plug	05Cr17Ni4Cu4Nb, 06Cr19Ni10, 06Cr17Ni12Mo2, 堆焊Stellite
5	阀芯 Cage	12Cr13, 06Cr19Ni10, 06Cr17Ni12Mo2 (镀镍Chromium plated, 氮化Nitriding, 堆焊Stellite)
6	填料 Packing	PTFE, 柔性石墨 (Flexible graphite)



固有流量特性 Inherent Flow Characteristics

- 标准阀内件有二种固有流量特性
- 线性特性和等百分比特性。
- 特性曲线见图2。
- 固有可调比: 50: 1



图2

外形尺寸 Overall Dimensions

外形尺寸见图3及下表
For overall dimensions, please see Fig. 3 and the following table:

压力等级 Pressure Class: 150-600

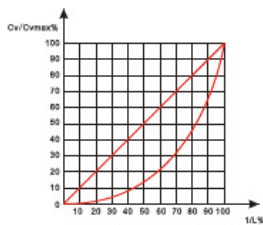
口径 Bore Diameter Inch	执行机构型号 37/38 Actuator Type	A				B	ΦC	H	
		压力等级 (ANSI Class) Pressure class						阀盖类型 Bonnet type	
		150-600	150	300	600			标准 Standard	延长 Extended
1	6#	222	184	197	210	67	292	662	765
1½	6#	222	222	235	251	67	292	665	768
2	6#	254	254	267	286	89	292	685	788
3	7A	318	298	318	337	96	384	858	982
3	7B	318	298	318	337	96	384	955	1080
4	7A	368	352	368	394	118	384	882	1008
4	7B	368	352	368	394	118	384	980	1105
6	8A	451	451	473	508	150	457	1125	1251
6	8B	451	451	473	508	150	457	1155	1280
8	8A	543	543	568	610	205	457	1171	1294
8	8B	543	543	568	610	205	457	1201	1327
10	8A	673	673	708	752	215	457	1255	1356
10	8B	673	673	708	752	215	457	1285	1386

外形尺寸 Overall Dimensions

压力等级 Pressure Class: 900-1500

口径 Bore Diameter Inch	执行机构型号 37/38 Actuator Type	A			B		ΦC	H	
		压力等级 (ANSI Class) Pressure class			900			阀盖类型 Bonnet type	
		900-1500	900	1500	900	1500		标准 Standard	延长 Extended
1	6#	235	273	273	77	77	292	662	765
1½	6#	235	311	311	77	77	292	665	768
2	6#	292	340	340	95	95	292	685	788
3	7A	318	387	406	116	124	384	858	982
3	7B	318	387	406	116	124	384	955	1080
4	7A	368	464	483	120	127	384	882	1008
4	7B	368	464	483	120	127	384	980	1105
6	8A	508	600	692	197	205	457	1125	1251
6	8B	508	600	692	197	205	457	1155	1280
8	8A	610	781	838	241	258	457	1171	1294
8	8B	610	781	838	241	258	457	1201	1327
10	8A	762	864	991	267	267	457	1255	1356
10	8B	762	864	991	267	267	457	1285	1386



图3

锻钢闸阀

- 承插焊闸阀
- 内螺纹闸阀
- 法兰闸阀
- 自密封闸阀
- 低温闸阀
- 放散管闸阀

Forged Gate Valve

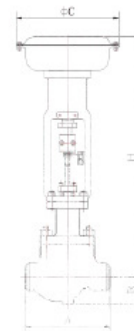
- Socket Weld End Gate Valve
- Thread End Gate Valve
- Flange End Gate Valve
- Pressure Seal Gate Valve
- Gate Valve For Cryogenic Service
- Bellow Gate Valve

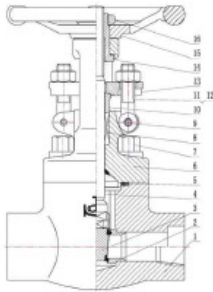

材料表 Material List

No.	Name	名称	Material List 材料表									
1	Body	阀体	A105	LF2	F5	F11	F22	F304	F304L	F316	F316L	
2	Seat Ring	阀座	410	316				304	304L	316	316L	
	Seat Surface	阀座密封面	STL	STL				STL				
3	Wedge	闸板	420	F316				304	304L	316	316L	
	Wedge Surface	闸板密封面	STL				STL					
4	Stem	阀杆	F6a	F316				F304	F304L	F316	F316L	
5	Gasket	垫片	304+柔性石墨304+Graphite				316L+柔性石墨316L+Graphite					
6	Bonnet	阀盖	A105	LF2	F5	F11	F22	F304	F304	LF316	F316L	
7	Bonnet Bolt	中法兰螺栓	A193 B7	A320 L7	A193 B16			A193 B8		A193 B8M		
8	Packing	填料	碳素纤维+柔性石墨 Carbon Fibre+Flexible Graphite Rings									
9	Eye Bolt Pin	销	35				12Cr13					
10	Gland	填料压套	410				304	304L	316	316L		
11	Gland Eye Bolt	活节螺栓	A193 B7	A320 L7	A193 B16			A193 B8				
12	Eye Bolt Nut	活节螺栓螺母	A194 2H	A194 4	A194 7				A194 8			
13	Gland Flange	填料压板	A105或WCB				304或CF8					
14	Stem Nut	阀杆螺母	410或QA19-4									
15	Handwheel	手轮	QT400									
16	Handwheel Nut	手轮螺母	CS碳钢				SS不锈钢					



应用规范

- 设计标准: ASME B16.34, API 602, JB/T 7746
- 承插焊: ASME B16.11, JB/T 7746
- 内螺纹: ASME B1.20.1, GB/T 7306
- 检验与试验标准: API 598, GB/T 13927

注: ①如需要可满足NACE MR-0175或SY/T 0599的要求

主要结构

- 明杆外螺纹和支架、升降杆、检修钩

主体材料

- A105, LF2, F5, F11, F22, F304, F316, F304L, F316L

Applicable Standards

- Design Specification: ASME B16.34, API 602, JB/T 7746
- Face to Face (End to End): ASME B16.11, JB/T 7746
- End Flange: ASME B1.20.1, GB/T 7306
- BW End: API 598, GB/T 13927

注: ①Meet NACE MR-0175 or SY/T 0599 on Request

Body Material

- A105, LF2, F5, F11, F22, F304, F316, F304L, F316L

Main Construction

- OS&Y, Rising Stem, Bolted Bonnet

尺寸及重量 Dimensions and Weights

压力等级	Class	口径	R.P	in	1/4	3/8	1/2	3/4	1	1 1/4	1 1/2	2	—
公称压力		NPS/DN	F.P	mm	8	10	15	20	25	32	40	50	—
Class150~800	1.6~14MPa	d	缩径	R.P	7	10	10	13	18	24	29	36.5	—
			全径	F.P	—	7	10	13	18	24	29	36.5	46.5
		L	R.P	79	79	79	92	111	120	120	140	—	—
			F.P	—	79	79	92	111	120	120	140	178	—
H~	开	R.P	149	151	151	158	185	239	243	279	—	—	
	Open	F.P	—	149	151	158	158	239	43	279	328	—	
W	R.P	100	100	100	100	125	160	160	180	—	—		
	F.P	—	100	100	100	125	160	160	180	200	—		
重量~ Weight(Kg)	R.P	1.9	1.9	1.9	2.1	3.2	6.9	6.9	10.4	—	—		
	F.P	—	1.9	1.9	2.1	3.2	6.9	6.9	10.4	15.8	—		
Class900~1500	16~25MPa	d	全径	R.P	—	7	10	13	18	24	29	36.5	46.5
			L	F.P	—	102	102	102	111	120	120	140	178
H~	开	R.P	—	166	166	169	230	246	283	330	180		
	Open	F.P	—	120	120	120	125	160	160	180	200		
W	R.P	—	166	166	169	230	246	283	330	180			
	F.P	—	120	120	120	125	160	160	180	200			
重量~ Weight(Kg)	R.P	—	3.6	3.5	3.4	3.8	7.8	11.9	12.2	21.9			
	F.P	—	3.6	3.5	3.4	3.8	7.8	11.9	12.2	21.9			

注: R.P代表缩径, F.P代表全径. R.P represents for "Reduce Port", F.P represents for "Full Port".

应用规范

- 设计标准: ASME B16.34, API 602
- 结构长度: ASME B16.10
- 法兰连接: ASME B16.5
- 检验与试验标准: API 598

注: ①如需要可满足NACE MR-0175要求

主要结构

- 明杆外螺纹和支架、升降杆、检修钩

主体材料

- A105, LF2, F5, F11, F22, F304, F316, F304L, F316L

Applicable Standards

- Design Specification: ASME B16.34, API 602
- Face to Face (End to End): ASME B16.10
- End Flange: ASME B16.5
- Inspection & Testing: API 598

注: ①Meet NACE MR-0175 on Request

Main Construction

- OS&Y, Rising Stem, Bolted Bonnet

Body Material

- A105, LF2, F5, F11, F22, F304, F316, F304L, F316L

尺寸及重量 Dimensions and Weights

压力等级	Class	口径	NPS(m)	1/2	3/4	1	1 1/4	1 1/2	2	2 1/2	
150	300	600	d (缩径 R.P)	10	12.7	19.1	24	31.8	38.1	48.5	
150	300	600	L	RF	108	117	127	140	165	178	
				RF	140	152	165	178	190	216	241
				RF	165	190	216	229	241	292	330
150	300	600	H(Open)~	RF	162	162	211	238	257	282	
				RF	162	162	211	238	257	282	
				RF	162	162	211	238	257	282	
150	300	600	W	RF	100	100	125	125	160	180	
				RF	100	100	125	125	160	180	
				RF	100	100	125	125	160	180	
150	300	600	重量~ Weight (kg)	RF	3.0	3.5	5.5	6.8	10.4	14.4	
				RF	3.6	4.9	7.0	9.4	13.3	18.0	
				RF	4.2	5.8	8.8	12.1	15.6	19.5	
900	~	1500	d(全径 F.P)	RF	13	18	24	29	36.5	46.5	
				RF	216	229	254	279	305	371	
				RF	197	211	238	257	276	320	
1500	~	1500	W	RF	125	125	160	160	200	250	
				RF	125	125	160	160	200	250	
				RF	7.2	11.5	15.6	16.2	22.6	28.2	

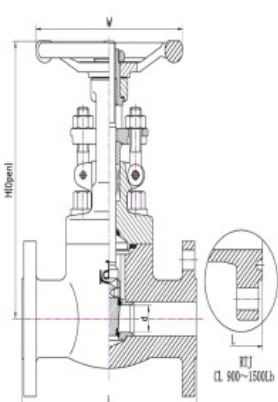

应用规范

- 设计标准: GB/T 12234, JB/T 7746
- 结构长度: JB/T 87
- 法兰连接: JB/T 82.1-82.4
- 检验与试验标准: GB/T 13927

主要结构

- 明杆外螺纹和支架、升降螺杆、检接筒盖

主体材料

- A105, LF2, F5, F11, F22, F304, F316, F304L, F316L

Applicable Standards

- Design Specification: GB/T 12234, JB/T 7746
- Face to Face (End to End): JB/T 87
- End Flange: JB/T 82.1-82.4
- Inspection & Testing: GB/T 13927

Note: ①Meet NACE SY/T 0599 on Request

Main Construction

- OS&Y, Rising Stem, Bolted Bonnet

Body Material

- A105, LF2, F5, F11, F22, F304, F316, F304L, F316L

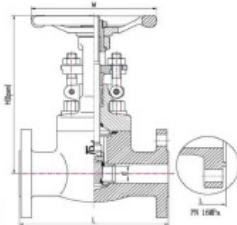

尺寸及重量 Dimensions and Weights

公称压力 PN	口径 DN	15	20	25	32	40	50	65	
1.6	d	10	12.7	19.1	24	31.8	38.1	50.8	
2.5		13	18	24	29	36.5	46.5	---	
4.0		130	150	160	180	200	250	285	
6.4		170	190	210	230	250	250	280	
10.0		170	190	210	230	260	300	---	
16.0	H(Open)≈	162	162	211	238	257	282	357	
1.6		W	100	100	125	125	160	180	200
2.5			125	125	160	257	160	250	---
4.0			2.8	3.2	4.9	5.8	9.8	12.8	23
6.4			3	3.5	5.5	6.6	10.4	14.4	14.5
10.0	3.8		4.9	7	9.4	13.3	18	26.2	
16.0	4.2	5.8	8.8	12.1	15.6	19.5	32		
重量 (kg)		7.2	11.5	15.6	16.2	22.6	28.2	---	

应用规范

- 设计标准: ASME B16.34, API 602, JB/T 7746
- 结构长度: ASME B16.10, JB/T 87
- 法兰连接: ASME B16.5, JB/T 82.1-82.4
- 内螺纹连接: ASME B16.11, JB/T 7746
- 内螺纹密封: ASME B1.20.1, GB/T 7306
- 检验与试验标准: API 598, GB/T 13927

主要结构

- 压力自密封阀盖、明杆外螺纹和支架、升降螺杆、手轮不升降

主体材料

- A105, LF2, F5, F11, F22, F304, F316, F304L, F316L

Applicable Standards

- Design Specification: ASME B16.34, API 602, JB/T 7746
- Face to Face (End to End): ASME B16.10, JB/T 87
- End Flange: ASME B16.5, JB/T 82.1-82.4
- Socket Weld End: ASME B16.11, JB/T 7746
- Thread End: ASME B1.20.1, GB/T 7306
- Inspection & Testing: API 598, GB/T 13927

尺寸及重量 Dimensions and Weights

压力等级 Class	口径 NPS(in) DN	1/2	3/4	1	1 1/4	1 1/2	2
CL900~ 1500 25MPa	d(全径/ F.P)	13	18	24	29	36.5	46.5
	L(SW/NPT/Rc)	140	140	140	178	178	216
	H(开/ Open)≈	321	321	321	380	414	502
	W	125	125	160	160	180	240
	重量Weight(kg)≈	11.5	11	10.2	20.5	21.7	43.5
2500 42MPa	d(全径/ F.P)	13	18	24	29	36.5	46.5
	L(RTJ)	216	229	254	279	305	371
	H(开/ Open)≈	321	321	321	380	414	502
	W	125	125	160	160	180	240
	重量Weight(kg)≈	16.7	16.7	21.3	24.5	28.7	45.8

应用规范

- 设计标准: ASME B16.34, BS 6364, JB/T 7749
- 法兰连接: ASME B16.5, JB/T 82.1-82.4
- 承插焊连接: ASME B16.11, JB/T 7746
- 内螺纹密封: ASME B1.20.1, GB/T 7306
- 检验与试验标准: API 598, JB/T 7749, BS 6364

Note: ①如需满足NACE MR-0175或SY/T 0599的要求

主要结构

- 明杆外螺纹和支架、升降螺杆、检接筒盖

主体材料

- LF2, LF3, F304, F316, F304L, F316L

使用温度

- LF2: T₃ = -46°C
- LF3: -101°C ≤ T < -46°C
- F304/F316: -196°C ≤ T < -101°C

Applicable Standards

- Design Specification: ASME B16.34, BS 6364, JB/T 7749
- End Flange: ASME B16.5, JB/T 82.1-82.4
- Socket Weld End: ASME B16.11, JB/T 7746
- Thread End: ASME B1.20.1, GB/T 7306
- Inspection & Testing: API 598, JB/T 7749, BS 6364

Note: ①Meet NACE MR-0175 or SY/T 0599 on Request

Main Construction

- OS&Y, Rising Stem, Bolted Bonnet

Body Material

- LF2, LF3, F304, F316, F304L, F316L

Working Temperature

- LF2: T₃ = -46°C
- LF3: -101°C ≤ T < -46°C
- F304/F316: -196°C ≤ T < -101°C

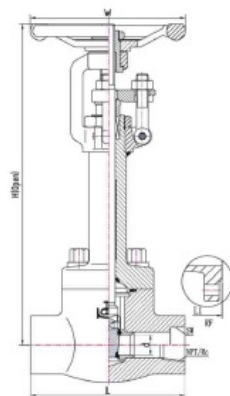

尺寸及重量 Dimensions and Weights

口径 DN	1/2	3/4	1	1 1/4	1 1/2	2
d(全径/ F.P)	13	18	24	29	36.5	46.5
L	92	111	120	120	140	178
L1	CL150, CL300	140	152	165	178	190
	CL600	165	190	218	229	241
	PN1.6-4.0	130	150	160	180	200
	PN6.4-10.0	170	190	210	230	250
H(开/ Open)	333	360	407	475	475	551
W	125	125	160	160	180	200
重量 Weight(kg)	SW/NPT/Rc	7.1	9.4	13.5	15	17.8
	CL150, CL300	7	9.4	12.5	19.8	20.1
	CL600	8	11.1	13.4	21.5	22.6

应用规范

- 设计标准: ASME B16.34, API 600
- 承插焊连接: ASME B16.11, JB/T 7746
- 内螺纹密封: ASME B1.20.1, GB/T 7306
- 检验与试验标准: API 598, JB/T 6169, MSS sp117

Note: ①如需满足NACE MR-0175或SY/T 0599的要求

主要结构

- 明杆外螺纹和支架、升降螺杆、检接筒盖、全通径、波纹管密封

主体材料

- A105, LF2, F304, F316, F304L, F316L

Applicable Standards

- Design Specification: ASME B16.34, API 600
- Socket Weld End: ASME B16.11, JB/T 7746
- Thread End: ASME B1.20.1, GB/T 7306
- Inspection & Testing: API 598, JB/T 6169, MSS sp117

Note: ①Meet NACE MR-0175 or SY/T 0599 on Request

Main Construction

- OS&Y, Rising Stem, Bolted Bonnet, Full Port, Bellow Sealed Stem

Body Material

- A105, LF2, F304, F316, F304L, F316L

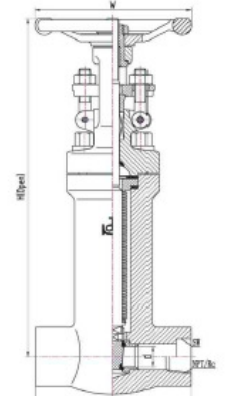

尺寸及重量 Dimensions and Weights

口径 DN	1/2	3/4	1	1 1/4	1 1/2	2
d(全径/ F.P)	13	18	24	29	36.5	46.5
L	92	111	120	120	140	178
H(开/ Open)≈	236	258	308	350	406	472
W	125	125	160	160	180	200
重量 Weight(kg)≈	2.9	3.2	5.9	8.7	10.2	16



锻钢截止阀

- 承插焊截止阀
- 内螺纹截止阀
- 法兰截止阀
- 自密封截止阀
- Y型截止阀
- 低温截止阀
- 波纹管截止阀
- 针形截止阀

Forged Globe Valve

- Socket Weld End Globe Valve
- Thread End Globe Valve
- Flange End Globe Valve
- Pressure Seal Globe Valve
- Y-Type Globe Valve
- Globe Valve For Cryogenic Service
- Bellow Globe Valve
- Needle Valve

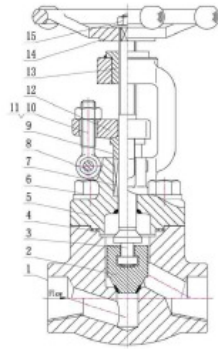

材料表 Material List

No.	Name	名称	Material List 材料表						
1	Body	阀体	A105	LF2	F5 F11 F22	F304	F304L	F316	F316L
	Seat Surface	阀座密封面	Cr13, STL		STL				
2	Disc	阀瓣			420		304	304L	316 316L
	Disc Surface	阀瓣密封面							STL
3	Stem	阀杆	F6a, F304, F316						
4	Gasket	垫片	304+柔性石墨304+Graphite			316L+柔性石墨316L+Graphite			
5	Bonnet	阀盖	A105	LF2	F5 F11 F22	F304	F304L	F316	F316L
6	Bonnet Bolt	中法兰螺栓	A193 B7	A320 L7	A193 B16		A193 B8		A193 B8M
7	Packing	填料	碳纤维+柔性石墨 Carbon Fibre+Flexible Graphite Rings						
8	Eye Bolt Pin	销	35						
9	Gland	填料压套	410						
10	Gland Eye Bolt	活节螺栓	A193 B7	A320 L7	A193 B16			A193 B8	
11	Eye Bolt Nut	活节螺栓螺母	A194 2H	A194 4	A194 7			A194	8
12	Gland Flange	填料压板	A105或WCB						
13	Stem Nut	阀杆螺母	410或QA19-4						
14	Handwheel	手轮	QT400						
15	Handwheel Nut	手轮螺母	C5碳钢			S5不锈钢			

应用规范

- 设计标准: ASME B16.34, API 602, JB/T 7746
- 承插焊端: ASME B16.11, JB/T 7746
- 内螺纹端: ASME B1.20.1, GB/T 7306
- 检验与试验标准: API 598, GB/T 13927

注

①如需要可满足NACE MR-0175或SY/T 0599的要求

主体结构

- 明杆外螺纹和支架、升降阀杆、柱塞式阀瓣、栓接阀盖

主体材料

- A105, LF2, F5, F11, F22, F304, F316, F304L, F316L

Applicable Standards

- Design Specification: ASME B16.34, API 602, JB/T 7746
- Socket Weld End: ASME B16.11, JB/T 7746
- Thread End: ASME B1.20.1, GB/T 7306
- Inspection & Testing: API 598, GB/T 13927

Note:

①Meet NACE MR-0175 or SY/T 0599 on Request

Main Construction

- OS&Y, Rising Stem, Plug Type Disc, Bolted Bonnet

Body Material

- A105, LF2, F5, F11, F22, F304, F316, F304L, F316L

尺寸及重量 Dimensions and Weights

Class	NPS/DN	R.P	压力等级											
			in	1/4	3/8	1/2	3/4	1	1 1/4	1 1/2	2	—		
公称压力	F.P		mm	8	10	15	20	25	32	40	50	—	—	—
PN			mm	—	8	10	15	20	25	32	40	50	—	—
CL150 ~ 800	d	缩径	R.P	7	10	10	13	18	24	29	36.5	—	—	—
			F.P	—	7	10	13	18	24	29	36.5	46.5	—	
1.6 ~ 14MPa	L	开	R.P	79	79	79	92	111	120	152	172	—	—	—
			F.P	—	79	79	92	111	120	150	172	200	—	—
1.6 ~ 14MPa	H~	Open	R.P	153	153	158	163	193	250	291	—	—	—	
			F.P	—	153	158	163	193	250	291	350	—	—	
1.6 ~ 14MPa	W	—	R.P	100	100	100	100	125	160	180	—	—	—	
			F.P	—	100	100	100	125	160	180	240	—	—	
CL1900 ~ 1500	d	全径	R.P	1.9	1.8	1.7	2.1	3.3	7.5	7.5	11.4	—	—	
			F.P	—	2.1	1.9	2.3	3.6	7.8	8.2	12.0	15.0	—	
16 ~ 25MPa	L	—	R.P	—	7	10	13	18	24	29	36.5	46.5	—	
			F.P	—	111	111	111	130	152	172	220	235	—	
16 ~ 25MPa	H~	Open	F.P	—	207	207	207	240	258	290	337	354	—	
			F.P	—	100	100	100	125	160	180	240	—	—	
16 ~ 25MPa	W	—	R.P	—	2.4	2.2	2	3.8	4.2	8	13.2	16.8	—	
			F.P	—	2.4	2.2	2	3.8	4.2	8	13.2	16.8	—	

注Note: R.P代表缩径, F.P代表全径. R.P represents for "Reduce Part", F.P represents for "Full Part".

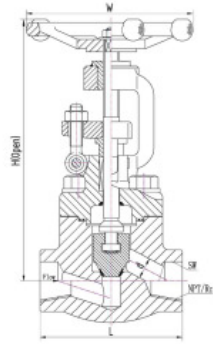

应用规范

- 设计标准: ASME B16.34, API 602
- 结构长度: ASME B16.10
- 法兰连接: ASME B16.5
- 检验与试验标准: API 598

注

①如需要可满足NACE MR-0175要求

主体结构

- 明杆外螺纹和支架、升降阀杆、柱塞式阀瓣、栓接阀盖

主体材料

- A105, LF2, F5, F11, F22, F304, F316, F304L, F316L

Applicable Standards

- Design Specification: ASME B16.34, API 602
- Face to Face (End to End): ASME B16.10
- End Flange: ASME B16.5
- Inspection & Testing: API 598

Note:

①Meet NACE MR-0175 on Request

Main Construction

- OS&Y, Rising Stem, Plug Type Disc, Bolted Bonnet

Body Material

- A105, LF2, F5, F11, F22, F304, F316, F304L, F316L

尺寸及重量 Dimensions and Weights

Class	NPS(in)	压力等级						
		1/2	3/4	1	1 1/4	1 1/2	2	2 1/2
150	d (缩径/R.P)	10	13	19.1	24	31.8	38.1	48.5
150	L	108	117	127	140	165	203	216
		152	178	203	216	229	267	292
300	H(Open)~	165	190	216	229	241	292	330
		158	163	193	250	250	291	350
600	W	100	100	125	160	160	180	240
		4.5	6.9	9.8	13.5	19.5	28.0	35.4
300	重量~	4.8	7.7	11.0	18.8	21.2	32.6	38.0
		5.6	7.8	12.5	17.0	23.5	38.8	42.6
900	d(全径/F.P)	13	18	24	29	36.5	46.5	—
		216	229	254	279	305	368	—
1500	H(Open)~	207	240	258	290	337	354	—
		100	125	160	160	180	240	—
1500	W	7.4	12.5	16	16.2	23	29.8	—
		7.4	12.5	16	16.2	23	29.8	—

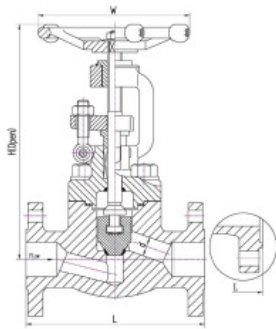

应用规范

- 设计标准: GB/T 12235, JB/T 7746
- 结构长度: JB/T 96
- 法兰连接: JB/T 82.1~82.4
- 检验与试验标准: GB/T 13927

注

①如需要可满足NACE MR-0175或SY/T 0599的要求

主体结构

- 明杆外螺纹和支架、升降阀杆、柱塞式阀瓣、栓接阀盖

主体材料

- A105, LF2, F5, F11, F22, F304, F316, F304L, F316L

Applicable Standards

- Design Specification: GB/T 12235, JB/T 7746
- Face to Face (End to End): JB/T 96
- End Flange: JB/T 82.1~82.4
- Inspection & Testing: GB/T 13927

Note:

①Meet NACE MR-0175 or SY/T 0599 on Request

尺寸及重量 Dimensions and Weights

Class	DN	公称压力										
		15	20	25	32	40	50	65	—	—	—	
1.6	d(缩径/R.P)	10	13	19.1	24	31.8	38.1	48.5	—	—	—	—
1.6	L	130	150	160	190	200	230	290	—	—	—	—
		170	190	210	230	260	300	340	—	—	—	
1.6	H(Open)~	158	163	193	250	250	291	350	—	—	—	—
		100	100	125	160	160	180	240	—	—	—	
1.6	重量~	3.8	4.5	5.8	6.3	9.1	13.7	24.5	—	—	—	—
		4	4.7	5.8	6.5	10.7	15.3	26.2	—	—	—	
1.6	d(全径/F.P)	4.3	5	6.3	7	12.3	18.8	27.7	—	—	—	—
		4.8	5.6	8	9.4	13.7	23.7	32	—	—	—	
16~25	H(Open)~	5.4	6.6	9.8	10.5	18.6	27.6	35	—	—	—	—
		13	18	24	29	36.5	46.5	—	—	—	—	
16~25	W	170	190	210	230	260	300	—	—	—	—	
		207	240	258	290	337	354	—	—	—	—	
16~25	Weight(kg)~	100	125	160	160	180	240	—	—	—	—	
		7.4	12.5	16	17.2	23	29.8	—	—	—	—	

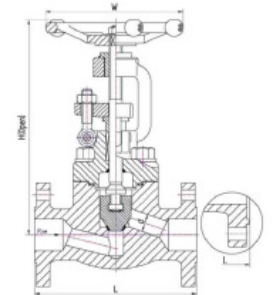



应用规范

- 设计标准: ASME B16.34, API 602, JB/T 7746
- 特殊长度: ASME B16.10, JB/T 96
- 法兰连接: ASME B16.5, JB/T 82.1 - 82.4
- 承插焊端: ASME B16.11, JB/T 7746
- 内螺纹端: ASME B1.20.1, GB/T 7306
- 检验与试验标准: API 598, GB/T 13927

注: ①如需要可满足NACE MR-0175或SY/T 0599的要求

主要结构

- 压力自密封阀座、明杆外螺纹和支架、升降阀杆、柱塞式阀盘、

主体材料

- A105, LF2, F5, F11, F22, F304, F316, F304L, F316L

Applicable Standards

- Design Specification: ASME B16.34, API 602, JB/T 7746
- Face to Face (End to End): ASME B16.10, JB/T 96
- End Flange: ASME B16.5, JB/T 82.1 - 82.4
- Socket Weld End: ASME B16.11, JB/T 7746
- Thread End: ASME B1.20.1, GB/T 7306
- Inspection & Testing: API 598, GB/T 13927

Note: ①Meet NACE MR-0175 or SY/T 0599 on Request

Main Construction

- Pressure Seal Bonnet, OS&Y, Rising Stem, Plug Type Disc

Body Material

- A105, LF2, F5, F11, F22, F304, F316, F304L, F316L

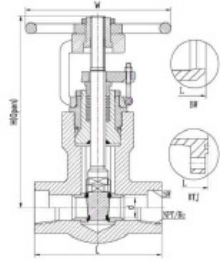

尺寸及重量 Dimensions and Weights

1. 承插焊/内螺纹连接 Socket Weld/Thread end

压力等级	Class	口径 DN	NPS	in	1/2	3/4	1	1 1/4	1 1/2	2
CL900~1500	16MPa	d(全径/ F.P)	13	18	24	29	36.5	46.5		
1500		L(SW/NPT/Rc)	140	140	140	178	178	216		
25MPa	16MPa	H(开/ Open)	207	207	240	258	290	337		
25MPa		W	125	125	160	160	180	240		
重量Weight(kg)≈			11.2	10.5	10.1	20.1	19.6	40.4		

2. 法兰连接 Flange end

压力等级	Class	口径 DN	NPS	in	1/2	3/4	1	1 1/4	1 1/2	2
CL900~1500	16MPa	d(全径/ F.P)	13	18	24	29	36.5	46.5		
1500		L(RTJ)	140	140	140	178	178	216		
16MPa	16MPa	H(开/ Open)	207	207	240	258	290	337		
16MPa		W	125	125	160	160	180	240		
重量Weight(kg)≈			15.5	16.9	16.9	25.5	34.3	52.8		
CL2500	42MPa	L(RTJ)	264	273	308	352	387	454		
42MPa		H(开/ Open)	333	333	333	383	420	524		
重量Weight(kg)≈			18.0	18.0	18.0	20.0	20.0	30.0		

3. 对焊连接 Butt Weld end

压力等级	Class	口径 DN	NPS	in	1/2	3/4	1	1 1/4	1 1/2	2
CL900~2500	16MPa	d(全径/ R.P)	10	13	18	25	32	38		
16MPa		L(W)	140	140	140	178	178	216		
16MPa	16MPa	H(开/ Open)	333	333	333	420	420	524		
16MPa		W	180	180	180	200	200	300		
重量(kg)			12.5	11.8	11.5	23.4	21.7	43.5		
≈			13.3	12.5	11.8	25.5	24.6	47.2		

应用规范

- 设计标准: ASME B16.34, API 602, JB/T 7746
- 承插焊端: ASME B16.11, JB/T 7746
- 内螺纹端: ASME B1.20.1, GB/T 7306
- 检验与试验标准: API 598, GB/T 13927

注: ①如需要可满足NACE MR-0175或SY/T 0599的要求

主要结构

- Y型阀体、明杆外螺纹和支架、升降阀杆、柱塞式阀盘、检接阀盖

主体材料

- A105, LF2, F5, F11, F22, F304, F316, F304L, F316L

Applicable Standards

- Design Specification: ASME B16.34, API 602, JB/T 7746
- Socket Weld End: ASME B16.11, JB/T 7746
- Thread End: ASME B1.20.1, GB/T 7306
- Inspection & Testing: API 598, GB/T 13927

Note: ①Meet NACE MR-0175 or SY/T 0599 on Request

Main Construction

- Y-Type Body, OS&Y, Rising Stem, Plug Type Disc, Bolted Bonnet

Body Material

- A105, LF2, F5, F11, F22, F304, F316, F304L, F316L

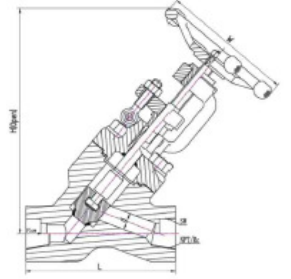

尺寸及重量 Dimensions and Weights

压力等级	Class	口径 DN	NPS	in	1/2	3/4	1	1 1/4	1 1/2	2	2 1/2
CL900	1.6	d(全径/ F.P)	13	18	24	29	36.5	46.5	64		
1.6		L	108	108	130	160	160	190	220		
14MPa	14MPa	H(开/ Open)	175	175	233	281	281	310	340		
14MPa		W	100	100	125	160	160	180	200		
重量Weight(kg)≈			2.6	2.3	5.5	15	14.7	27	36.8		
CL1500	25MPa	d(全径/ F.P)	13	18	24	29	36.5	46.5	64		
25MPa		L	130	130	180	190	190	220	260		
25MPa	25MPa	H(开/ Open)	225	225	274	307	307	356	472		
25MPa		W	125	125	160	180	180	200	300		
重量Weight(kg)≈			3.8	4.2	7.8	17.2	17.6	29.1	40.4		



应用规范

- 设计标准: ASME B16.34, BS 6364, JB/T 7749
- 法兰连接: ASME B16.5, JB/T 82.1 - 82.4
- 承插焊端: ASME B16.11, JB/T 7746
- 内螺纹端: ASME B1.20.1, GB/T 7306
- 检验与试验标准: API 598, JB/T 7749, BS6364

注: ①如需要可满足NACE MR-0175或SY/T 0599的要求

主要结构

- 明杆外螺纹和支架、升降阀杆、柱塞式阀盘、检接阀盖

主体材料

- LF2, LF3, F304, F316, F304L, F316L

使用温度

- LF2: T₂₀ - 46°C
- LF3: -101°C ≤ T < -46°C
- F304/F316: -196°C ≤ T < -101°C

Applicable Standards

- Design Specification: ASME B16.34, BS 6364, JB/T 7749
- End Flange: ASME B16.5, JB/T 82.1 - 82.4
- Socket Weld End: ASME B16.11, JB/T 7746
- Thread End: ASME B1.20.1, GB/T 7306
- Inspection & Testing: API 598, JB/T 7749, BS6364

Note: ①Meet NACE MR-0175 or SY/T 0599 on Request

Main Construction

- OS&Y, Rising Stem, Bolted Bonnet, Full Port, Bellows Sealed Stem

Body Material

- LF2, LF3, F304, F316, F304L, F316L

Working Temperature

- LF2: T₂₀ - 46°C
- LF3: -101°C ≤ T < -46°C
- F304/F316: -196°C ≤ T < -101°C

尺寸及重量 Dimensions and Weights

压力等级	Class	口径 DN	NPS	in	1/2	3/4	1	1 1/4	1 1/2	2
CL150~CL300	16MPa	d(全径/ F.P)	13	18	24	29	36.5	46.5		
1500		L	92	92	111	120	172	200		
16MPa	16MPa	H(开/ Open)	339	370	410	474	474	546		
16MPa		W	125	125	160	180	180	200		
重量Weight(kg)			7.2	9.5	13.5	20.6	19.8	29		
CL150~CL300	42MPa	L	165	190	218	229	241	292		
42MPa		H(开/ Open)	339	370	410	474	474	546		
重量Weight(kg)			8.4	10.2	15	23	22	33.4		
≈			9.6	12.7	18.1	25.8	25	36		

注Note: H1尺寸根据用户要求, H1 meet customers requirements.

应用规范

- 设计标准: ASME B16.34, API 600
- 法兰连接: ASME B16.5, JB/T 82.1 - 82.4
- 承插焊端: ASME B16.11, JB/T 7746
- 内螺纹端: ASME B1.20.1, GB/T 7306
- 检验与试验标准: API 598, JB/T 6169, MSS SP 117

注: ①如需要可满足NACE MR-0175或SY/T 0599的要求

主要结构

- 明杆外螺纹和支架、升降阀杆、检接阀盖、全通径、波纹管密封

主体材料

- A105, LF2, F304, F316, F304L, F316L

Applicable Standards

- Design Specification: ASME B16.34, API 600
- End Flange: ASME B16.5, JB/T 82.1 - 82.4
- Socket Weld End: ASME B16.11, JB/T 7746
- Thread End: ASME B1.20.1, GB/T 7306
- Inspection & Testing: API 598, JB/T 6169

Note: ①Meet NACE MR-0175 or SY/T 0599 on Request

Main Construction

- OS&Y, Rising Stem, Bolted Bonnet, Full Port, Bellows Sealed Stem

Body Material

- A105, LF2, F304, F316, F304L, F316L

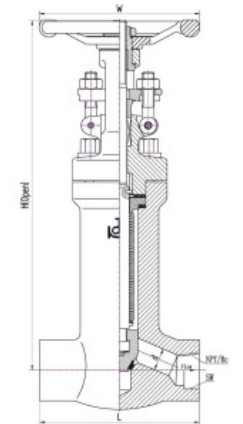

尺寸及重量 Dimensions and Weights

压力等级	Class	口径 DN	NPS	in	1/2	3/4	1	1 1/4	1 1/2	2
CL150~CL300	16MPa	d(全径/ F.P)	13	18	24	29	36.5	46.5		
1500		L	79	92	111	130	152	172		
16MPa	16MPa	H(开/ Open)	209	209	232	300	300	321		
16MPa		W	125	125	125	160	160	180		
重量Weight(kg)≈			3	4.8	7.9	11	16.8	25.2		

针形截止阀
NEEDLE VALVE
---CLASS 150 - 600 & PN 1.6 - 10.0MPa---



锻钢止回阀
FORGED CHECK VALVE

应用规范

- 设计标准: ASME B16.34, API 602, JB/T 7746
- 承压规范: ASME B16.11, JB/T 7746
- 内螺纹规范: ASME B1.20.1, GB/T 7306
- 检验与试验标准: API 598, GB/T 13927

注
①如需要可满足NACE MR-0175或SY/T 0599的要求

主要结构

- 明杆外螺纹和支架、升降阀杆、锥塞式阀瓣、栓接阀盖

主体材料

- A105, LF2, F5, F11, F22, F304, F316, F304L, F316L

Applicable Standards

- Design Specification: ASME B16.34, API 602, JB/T 7746
- Socket Weld End: ASME B16.11, JB/T 7746
- Thread End: ASME B1.20.1, GB/T 7306
- Inspection & Testing: API 598, GB/T 13927

Note:
①Meet NACE MR-0175 or SY/T 0599 on Request

Main Construction

- OS&Y, Rising Stem, Plug Type Disc, Bolted Bonnet

Body Material

- A105, LF2, F5, F11, F22, F304, F316, F304L, F316L

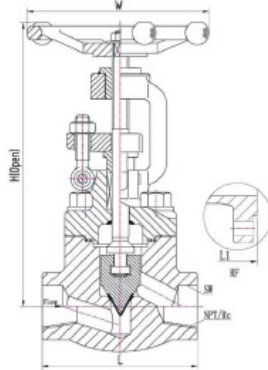

锻钢止回阀

- 承插焊止回阀
- 内螺纹止回阀
- 法兰止回阀
- 黄铜止回阀
- Y型止回阀

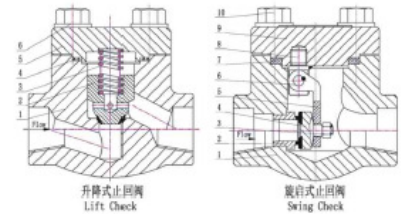

Forged Gate Valve

- Socket Weld End Check Valve
- Thread End Check Valve
- Flange End Check Valve
- Pressure Seal Check Valve
- Y-Type Check Valve

材料表 Material List

1. 升降止回阀 Lift Check Valve

No.	Name	名称	Material List 材料表											
			A105	LF2	F5	F11	F22	F304	F304L	F316	F316L			
1	Body	阀体	STL											
	Seat Surface	阀座密封面	Cr13, STL											
2	Disc	阀瓣	420											
	Disc Surface	阀瓣密封面										F304	F304L	F316
3	Spring	弹簧	SS不锈钢											
									Inconel X-750					
			304+柔性石墨304+Graphite					316L+柔性石墨316L+Graphite						
5	Bonnet	阀盖	A105	LF2	F5	F11	F22	F304	F304L	F316	F316L			
6	Bonnet Bolt	中法兰螺栓	A193 B7	A320 L7	A193	B16						A193 B8	A193 B8M	

2. 旋启式止回阀 Swing Check Valve

No.	Name	名称	Material List 材料表										
			A105	LF2	F5	F11	F22	F304	F304L	F316	F316L		
1	Body	阀体	A105										
2	Seat	阀座	420										
	Seat Surface	阀座密封面	Cr13, STL										
3	Disc Nut	阀瓣螺母	SS不锈钢										
	Disc	阀瓣	A105	LF2	F5	F11	F22	F304	F304L	F316	F316L		
4	Disc Surface	阀瓣密封面	Cr13, STL										
	Disc	阀瓣	A105	LF2	F5	F11	F22	F304	F304L	F316	F316L		
5	Arm	摇臂	A105	LF2	F5	F11	F22	F304	F304L	F316	F316L		
6	Pin	销轴	420										
7	Gasket	垫片	304+柔性石墨304+Graphite					316L+柔性石墨316L+Graphite					
			A105	LF2	F5	F11	F22	F304	F304L	F316	F316L		
9	Bonnet	阀盖	A105	LF2	F5	F11	F22	F304	F304L	F316	F316L		
10	Bonnet Bolt	中法兰螺栓	A193 B7	A320 L7	A193	B16						A193 B8	A193 B8M

注Note: 升降止回阀可以不带弹簧。Lift check valve without spring is Available

尺寸及重量 Dimensions and Weights

直径	NPS		1/4	3/8	1/2	3/4	1	1 1/2	1 3/4	2
	DN	mm	8	10	15	20	25	32	40	50
d(全径/ F.P)			7	10	10	13	18	24	29	36.5
L	SW, NPT或Rc		79	79	79	92	111	120	152	172
	L1	RF	CL150	102	102	108	117	127	140	165
		CL300	--	--	152	178	203	216	229	267
		CL600	--	--	165	190	216	229	241	292
		PN1.6~4.0	--	--	130	150	160	190	200	230
	PN6.4~10.0	--	--	170	190	210	230	260	300	
H(升/ Open)			153	153	158	192	252	252	289	330
W			100	100	100	100	125	160	160	200
重量Weight(kg)~			1.8	1.8	1.7	2.1	3.3	4.8	7.2	11.5

承插焊/内螺纹止回阀
SOCKET WELD/THREAD END CHECK VALVE
---CLASS 150 - 1500 & PN 1.6 - 25.0MPa---



法兰止回阀
FLANGE END CHECK VALVE
CLASS 150 - 600 & PN1.6 - 10.0MPa

应用规范

- 设计标准: ASME B16.34, API 602, JB/T 7746
- 承压规范: ASME B16.11, JB/T 7746
- 内螺纹规范: ASME B1.20.1, GB/T 7306
- 检验与试验标准: API 598, GB/T 13927

注
①如需要可满足NACE MR-0175或SY/T 0599的要求

主要结构

- A. 升降止回阀: 锥塞式阀瓣、栓接阀盖
- B. 旋启式止回阀: 瓣板式阀瓣、栓接阀盖

主体材料

- A105, LF2, F5, F11, F22, F304, F316, F304L, F316L

Applicable Standards

- Design Specification: ASME B16.34, API 602, JB/T 7746
- Socket Weld End: ASME B16.11, JB/T 7746
- Thread End: ASME B1.20.1, GB/T 7306
- Inspection & Testing: API 598, GB/T 13927

Note:
①Meet NACE MR-0175 or SY/T 0599 on Request

Main Construction

- Lift Check Valve: Plug Type Disc, Bolted Bonnet
- Swing Check Valve: Rolled Seat, Bolted Bonnet

Body Material

- A105, LF2, F5, F11, F22, F304, F316, F304L, F316L

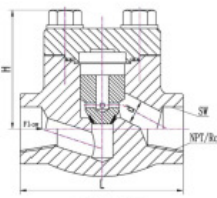

升降止回阀
Lift Check

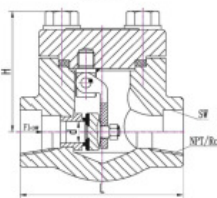

旋启式止回阀
Swing Check

尺寸及重量 Dimensions and Weights

压力等级	Class	公称压力	PN	直径	R.P	1/4	3/8	1/2	3/4	1	1 1/2	1 3/4	2	-
						mm	8	10	15	20	25	32	40	50
			d(全径/ F.P)			7	10	10	13	18	24	29	36.5	46.5
800	CL150~	L	升降式	Lift	79	79	79	92	111	120	152	172	200	
			旋启式	Swing	79	79	79	92	111	120	120	140	170	
H~		升降式	Lift	61	61	61	61	78	84	103	118	132		
		旋启式	Swing	61	61	61	61	78	84	101	120	133		
14MPa	CL900~	重量~	Lift	1.5	1.4	1.2	1.4	2.3	3.9	5.6	8.9	12.5		
			Swing	1.3	1.2	1.0	1.1	1.9	3.4	4.5	7.3	10.0		
d		全径	F.P	--	--	--	--	13	18	24	29	36.5	46.5	
1500		CL300~	L	升降式	Lift	--	--	--	111	111	130	152	172	220
	旋启式			Swing	--	--	--	111	111	120	140	162		
H~	升降式		Lift	--	--	--	--	79	97	104	120	139	158	
	旋启式		Swing	--	--	--	--	79	97	115	133	149	166	
25MPa	CL600~	重量~	Lift	--	--	--	--	3.4	4.8	6.9	10.7	8.8	12.3	
			Swing	--	--	--	--	3.8	4.3	10.7	14.6	12.8	15.5	
d		全径	F.P	--	--	--	--	13	18	24	29	36.5	46.5	
16~		CL150~	L	升降式	Lift	--	--	--	111	111	130	152	172	220
	旋启式			Swing	--	--	--	111	111	120	140	162		
H~	升降式		Lift	--	--	--	--	79	97	104	120	139	158	
	旋启式		Swing	--	--	--	--	79	97	115	133	149	166	
重量	Weight(kg)	Lift	--	--	--	--	3.4	4.8	6.9	10.7	8.8	12.3		
			Swing	--	--	--	--	3.8	4.3	10.7	14.6	12.8	15.5	
d		全径	F.P	--	--	--	--	13	18	24	29	36.5	46.5	
16~		CL300~	L	升降式	Lift	--	--	--	111	111	130	152	172	220
	旋启式			Swing	--	--	--	111	111	120	140	162		
H~	升降式		Lift	--	--	--	--	79	97	104	120	139	158	
	旋启式		Swing	--	--	--	--	79	97	115	133	149	166	
重量	Weight(kg)	Lift	--	--	--	--	3.4	4.8	6.9	10.7	8.8	12.3		
			Swing	--	--	--	--	3.8	4.3	10.7	14.6	12.8	15.5	
d		全径	F.P	--	--	--	--	13	18	24	29	36.5	46.5	
16~		CL600~	L	升降式	Lift	--	--	--	111	111	130	152	172	220
	旋启式			Swing	--	--	--	111	111	120	140	162		
H~	升降式		Lift	--	--	--	--	79	97	104	120	139	158	
	旋启式		Swing	--	--	--	--	79	97	115	133	149	166	
重量	Weight(kg)	Lift	--	--	--	--	3.4	4.8	6.9	10.7	8.8	12.3		
			Swing	--	--	--	--	3.8	4.3	10.7	14.6	12.8	15.5	
d		全径	F.P	--	--	--	--	13	18	24	29	36.5	46.5	
16~		CL150~	L	升降式	Lift	--	--	--	111	111	130	152	172	220
	旋启式			Swing	--	--	--	111	111	120	140	162		
H~	升降式		Lift	--	--	--	--	79	97	104	120	139	158	
	旋启式		Swing	--	--	--	--	79	97	115	133	149	166	
重量	Weight(kg)	Lift	--	--	--	--	3.4	4.8	6.9	10.7	8.8	12.3		
			Swing	--	--	--	--	3.8	4.3	10.7	14.6	12.8	15.5	
d		全径	F.P	--	--	--	--	13	18	24	29	36.5	46.5	
16~		CL300~	L	升降式	Lift	--	--	--	111	111	130	152	172	220
	旋启式			Swing	--	--	--	111	111	120	140	162		
H~	升降式		Lift	--	--	--	--	79	97	104	120	139	158	
	旋启式		Swing	--	--	--	--	79	97	115	133	149	166	
重量	Weight(kg)	Lift	--	--	--	--	3.4	4.8	6.9	10.7	8.8	12.3		
			Swing	--	--	--	--	3.8	4.3	10.7	14.6	12.8	15.5	
d		全径	F.P	--	--	--	--	13	18	24	29	36.5	46.5	
16~		CL600~	L	升降式	Lift	--	--	--	111	111	130	152	172	220
	旋启式			Swing	--	--	--	111	111	120	140	162		
H~	升降式		Lift	--	--	--	--	79	97	104	120	139		



应用规范

- 设计标准:ASME B16.34,API 602,JB/T 7746
结构长度:ASME B16.10,JB/T 96
法兰连接:ASME B16.5,JB/T 82.1-82.4
检验与试验标准:API 598,GB/T 13927

注:①如需要可满足NACE MR-0175或SY/T 0599的要求

主要结构

- 压力自密封阀盖、升降止回、锥塞式阀瓣。

主体材料

- A105, LF2, F5, F11, F22, F304, F316, F304L, F316L

Applicable Standards

- Design Specification:ASME B16.34,API 602,JB/T 7746
Face to Face (End to End):ASME B16.10,JB/T 96
End Flange:ASME B16.5,JB/T 82.1-82.4
Inspection & Testing:API 598,GB/T 13927

Note: ①Meet NACE MR-0175 or SY/T 0599 on Request

Main Construction

- Pressure Seal Bonnet, Lift Check, Plug Type Disc

Body Material

- A105, LF2, F5, F11, F22, F304, F316, F304L, F316L

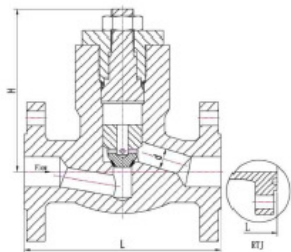

尺寸及重量 Dimensions and Weights

Table with columns for Diameter (NPS, in, DN, mm), L(RF), H, and Weight (kg) for various valve sizes (1/2, 3/4, 1, 1 1/4, 1 1/2, 2).

上阀牌安全阀ShangFa® Safety Valve

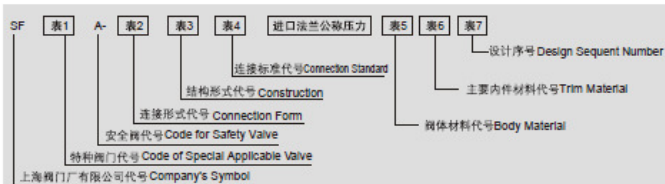

特种阀门代号按表1的规定 Code for Special Applicable Valve as Follows:

Table 1: Special Applicable Valve codes. Columns include Special Type Valve, Code, Special Type Valve, Code, Special Type Valve, Code, and Low Temperature Valve, Code.

附注:1 特种阀门含义包括在特殊工况使用或特殊结构的阀门。

2 编号是先特殊工况后特殊结构。

3 通用阀门省略特殊工况代号。

4 一种阀门同时包含多种特殊结构则在表中顺序编写代号。

Notes: Special Type Valve means the valve is applied for special services or the valve with special construction;

When compiling, code for special services shall go first and follow the construction code;

Code for special service application shall be omitted for General Valves.

When a valve includes several special construction, model shall be compiled according to the sequence of code listed in the table above.

连接形式代号按表2的规定 Code of connection form refers to Arabic number as follows: (Figure 2)

Table 2: Connection form codes. Columns include Special Type Valve, Code, Special Type Valve, Code, and Special Type Valve, Code.

结构形式代号按表3的规定 Code of Structural form refers to Arabic number as follows: (Figure 3)

Table 3: Structural form codes. Columns include Structural form of safety valve, Code, and Structural form of safety valve, Code.

应用规范

- 设计标准:ASME B16.34,API 602,JB/T 7746
承压等级:ASME B16.11,JB/T 7746
内螺纹连接:ASME B1.20.1,GB/T 7306
检验与试验标准:API 598,GB/T 13927

注:①如需要可满足NACE MR-0175或SY/T 0599的要求

主要结构

- Y型阀体、带弹簧升降式、锥塞式阀瓣、焊接阀盖

主体材料

- A105, LF2, F5, F11, F22, F304, F316, F304L, F316L

Applicable Standards

- Design Specification:ASME B16.34,API 602,JB/T 7746
Socket Weld End:ASME B16.11,JB/T 7746
Thread End:ASME B1.20.1,GB/T 7306
Inspection & Testing:API 598,GB/T 13927

Note: ①Meet NACE MR-0175 or SY/T 0599 on Request

Main Construction

- Y-Type Body, Lift Check With Spring, Plug Type Disc, Welded Bonnet

Body Material

- A105, LF2, F5, F11, F22, F304, F316, F304L, F316L

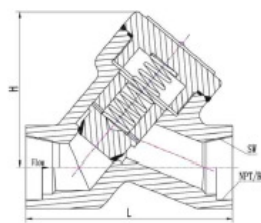

尺寸及重量 Dimensions and Weights

Table with columns for Diameter (NPS, in, DN, mm), L(RF), H, and Weight (kg) for various valve sizes (1/4, 3/8, 1/2, 3/4, 1, 1 1/4, 1 1/2, 2).

上阀牌安全阀ShangFa® Safety Valve

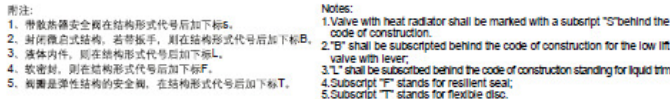

连接标准代号按表4的规定 Code for connection standard as follows:

Table 4: Connection standard codes. Columns include Connection Standard, Code, Connection Standard, Code, and Connection Standard, Code.

阀体材料代号按表5的规定 Code for Body Material

Table 5: Body material codes. Columns include Body material, Code, Body material, Code, Body material, Code, and Body material, Code.

主要内件材料代号按表6的规定 The main pieces of material inside the code

Table 6: Main pieces of material codes. Columns include Main pieces of material inside, Code, Main pieces of material inside, Code, Body material, Code, and Body material, Code.

注: 主要内件为一次压力区承压零件, 有时可以省略。

Note: Trims are the pressure retaining parts for each given pressure. It can be omitted sometime.

型号的名称编制方法示例 Example for Model Compiling:

示例Example: SFWA-42C 150CR01

进口法兰压力级为CL 150, 阀体材料为碳钢, 主要内件为316L, 带波纹管密封全启式安全阀, 设计序号为1。

Full lift safety valve, input Flange Class: 150LB, Body Material: Carbon steel, trims:316L, with Bellows; Design Number:1

SFA系列安全阀 SFA Series Products

SFA波纹管平衡式系列安全阀 Series SFA, Balanced Bellows Safety Valve

连接法兰标准按Flange standard:ANSI B 16.5

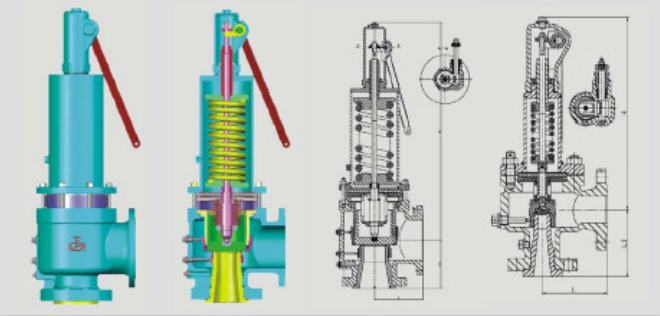

参数表Specification

型号 Model	压力级 (LB) CL	公称直径 Nominal Diameter (in)	流通直径 Flow Diameter (mm)	连接尺寸(进口/出口) Connection Size		材料 Material						适用条件 Applicable Service			
				进口(In) Input	出口(Out) Output	阀体 Body	阀座 Seat	阀瓣 Disc	弹簧 Spring	波纹管 Bellows	介质 Medium	温度 < T Temp.	背压 < P Back Pressure (MPa)	L (mm)	L1 (mm)
SFWA-41cC300C1	ANSI 300	1/2	6	11/2"300	11/2"150	20	25	304	50CrVA	316L	气体 Gas, 液体 Liquid	300	0.4	90	90
SFWA-41C300C1	ANSI 300	3/4	10	3/4"300	11/2"150	20	25	304	50CrVA	316L	气体 Gas, 液体 Liquid	300	0.6	115	105
SFWA-41C300P1	ANSI 300	3/4	12	3/4"300	11/2"150	304	304	304	50CrVA	316L	气体 Gas, 液体 Liquid	200	0.4	115	105
SFWA-41cC150C1	ANSI 150	1	16	1"150	1"150	WCB	20Cr13	20Cr13	50CrVA	316L	气体 Gas, 液体 Liquid	300	0.25	100	100
SFWA-41cC300C1	ANSI 300	1	20	1"300	2"150	WCB	20Cr13	20Cr13	50CrVA	316L	气体 Gas, 液体 Liquid	300	0.4	114	105
SFWA-41cC300C3	ANSI 300	1	16	1"300	2"150	WCB	20Cr13	20Cr13	50CrVA	316L	气体 Gas, 液体 Liquid	300	0.4	114	105
SFWA-44C1500C1	ANSI1500	1	16	1"1500	11/2"150	WCB	20Cr13	20Cr13	50CrVA	316L	气体 Gas, 液体 Liquid	300	0.8	150	150
SFWA-41cC150C1	ANSI 150	11/2	30	11/2"150	2"150	WCB	20Cr13	20Cr13	50CrVA	316L	气体 Gas, 液体 Liquid	300	0.2	100	110
SFWA-42C150C2	ANSI 150	11/2	20	11/2"150	21/2"150	WCB	20Cr13	20Cr13	50CrVA	316L	气体 Gas, 液体 Liquid	300	0.25	121	124
SFWA-42C150C3	ANSI 150	11/2	25	11/2"150	3"150	WCB	20Cr13	20Cr13	50CrVA	316L	气体 Gas, 液体 Liquid	300	0.25	124	130
SFWA-44C150C1	ANSI 150	11/2	25	11/2"150	2"150	WCB	20Cr13	20Cr13	50CrVA	316L	气体 Gas, 液体 Liquid	300	0.25	100	110
SFWA-44cC600C3	ANSI 600	11/2	25	11/2"600	2"300	WCB	20Cr13	20Cr13	50CrVA	316L	气体 Gas, 液体 Liquid	300	2	110	115
SFWA-44C600C1	ANSI 600	11/2	25	11/2"600	21/2"150	WCB	20Cr13	20Cr13	50CrVA	316L	气体 Gas, 液体 Liquid	300	0.6	152	124

SFA系列安全阀 SFA Series Products

SFA保温波纹管平衡式系列安全阀 SFA insulation series bellows balanced safety valve

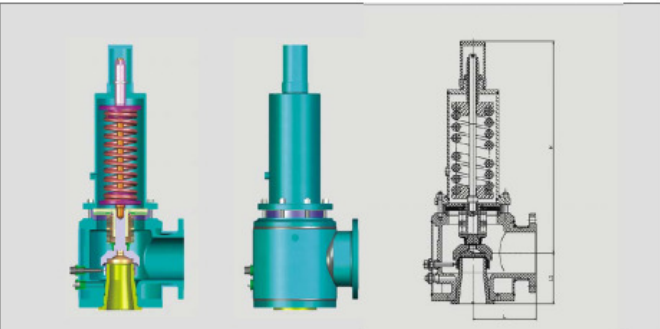

参数表Specification

型号 Model	压力级 (LB) CL	公称直径 Nominal Diameter (in)	流通直径 Flow Diameter (mm)	连接尺寸(进口/出口) Connection Size		材料 Material						适用条件 Applicable Service				
				进口(In) Input	出口(Out) Output	阀体 Body	阀座 Seat	阀瓣 Disc	弹簧 Spring	波纹管 Bellows	介质 Medium	温度 < T Temp.	L (mm)	L1 (mm)	备注 Remarks	
SFBWA-42C150R01	ANSI150	11/2	20	11/2"150	21/2"150	F316L	F316L	F316L	50CrVA	316L	气体 Gas, 液体 Liquid	≤200		121	124	
		2	33	2"150	3"150	F316L	F316L	F316L	50CrVA	316L	气体 Gas, 液体 Liquid	≤200		124	136	
		3	40	3"150	4"150	F316L	F316L	F316L	50CrVA	316L	气体 Gas, 液体 Liquid	≤200		162	165	
		4	74	4"150	6"150	F316L	F316L	F316L	50CrVA	316L	气体 Gas, 液体 Liquid	≤200		228	181	
SFBWA-42C600R01	ANSI600	4	50	4"600	6"150	F316L	F316L	F316L	50CrVA	316L	气体 Gas, 液体 Liquid	≤365		203	180	
SFBWA-42C1500R01	ANSI1500	2	26	2"1500	3"300	F316L	F316L	F316L	50CrVA	316L	气体 Gas, 液体 Liquid	≤200		162	154	

SFA系列安全阀 SFA Series Products

型号 Model	压力级 (LB) CL	公称直径 Nominal Diameter (in)	流通直径 Flow Diameter (mm)	连接尺寸(进口/出口) Connection Size		材料 Material						适用条件 Applicable Service			
				进口(In) Input	出口(Out) Output	阀体 Body	阀座 Seat	阀瓣 Disc	弹簧 Spring	波纹管 Bellows	介质 Medium	温度 < T Temp.	背压 < P Back Pressure (MPa)	L (mm)	L1 (mm)
SFWA-44C900C1	ANSI 900	11/2	20	11/2"900	2"150	WCB	20Cr13	20Cr13	50CrVA	316L	气体 Gas, 液体 Liquid	300	0.8	160	160
SFWA-44C150C1	ANSI 150	2	32	2"150	3"150	WCB	20Cr13	20Cr13	50CrVA	316L	气体 Gas, 液体 Liquid	300	0.25	125	145
SFWA-41cC300C1	ANSI 300	2	40	2"300	3"150	WCB	20Cr13	20Cr13	50CrVA	316L	气体 Gas, 液体 Liquid	300	0.4	145	150
SFWA-42C300P2	ANSI 300	2	26	2"300	3"150	CF8M	316	316	50CrVA	316L	气体 Gas, 液体 Liquid	200	0.4	124	130
SFWA-44C300C3	ANSI 300	2	40	2"300	3"150	WCB	20Cr13	20Cr13	50CrVA	316L	气体 Gas, 液体 Liquid	300	0.4	124	136
SFWA-44cC300C1	ANSI 300	2	32	2"300	3"150	WCB	12Cr1Mo	17-4PH	50CrVA	316L	气体 Gas, 液体 Liquid	510	0.24	124	130
SFWA-44C600C1	ANSI 600	2	32	2"600	3"150	WCB	20Cr13	20Cr13	50CrVA	316L	气体 Gas, 液体 Liquid	300	0	162	154
SFWA-42C150R1	ANSI 150	3	50	3"150	4"150	CF8M	316	316	50CrVA	316L	气体 Gas, 液体 Liquid	200	0.25	165	155
SFWA-44C150C3	ANSI 150	3	65	3"150	6"150	WCB	20Cr13	20Cr13	50CrVA	316L	气体 Gas, 液体 Liquid	300	0.25	165	170
SFWA-44C300C3	ANSI 300	3	57	3"300	4"150	WCB	20Cr13	20Cr13	50CrVA	316L	气体 Gas, 液体 Liquid	300	0.4	165	155
SFWA-42C150C1	ANSI 150	4	65	4"150	6"150	WCB	20Cr13	20Cr13	50CrVA	316L	气体 Gas, 液体 Liquid	300	0.25	210	197
SFWA-42C150C2	ANSI 150	4	57	4"150	6"150	WCB	20Cr13	20Cr13	50CrVA	316L	气体 Gas, 液体 Liquid	300	0.25	184	178
SFWA-42C150C3	ANSI 150	4	77	4"150	6"150	WCB	20Cr13	20Cr13	50CrVA	316L	气体 Gas, 液体 Liquid	300	0.25	229	181
SFWA-42C150P3	ANSI 150	4	77	4"150	6"150	CF8M	316	316	50CrVA	316L	气体 Gas, 液体 Liquid	200	0.25	229	181
SFWA-42C1500C1	ANSI 150	4	77	4"150	6"150	WCB	20Cr13	20Cr13	50CrVA	316L	气体 Gas, 液体 Liquid	300	0.25	175	180
SFWA-44C300C1	ANSI 300	4	70	4"300	6"150	WCB	20Cr13	20Cr13	50CrVA	316L	气体 Gas, 液体 Liquid	300	0.4	210	197
SFWA-44C300C6	ANSI 300	4	77	4"300	6"150	WCB	20Cr13	20Cr13	50CrVA	316L	气体 Gas, 液体 Liquid	300	0.4	229	181
SFWA-42C150C5	ANSI 150	6	100	6"150	8"150	WCB	20Cr13	20Cr13	50CrVA	316L	气体 Gas, 液体 Liquid	300	0.25	241	240
SFWA-42C150C6	ANSI 150	6	115	6"150	8"150	WCB	20Cr13	20Cr13	50CrVA	316L	气体 Gas, 液体 Liquid	300	0.25	241	240
SFWA-42C150C7	ANSI 150	6	95	6"150	8"150	WCB	20Cr13	20Cr13	50CrVA	316L	气体 Gas, 液体 Liquid	300	0.25	241	240
SFWA-44C150C1	ANSI 150	6	110	6"150	8"150	WCB	20Cr13	20Cr13	50CrVA	316L	气体 Gas, 液体 Liquid	300	0.25	241	240
SFWA-44C150C2	ANSI 150	6	110	6"150	10"150	WCB	20Cr13	20Cr13	50CrVA	316L	气体 Gas, 液体 Liquid	300	0.25	225	245
SFWA-44C150C3	ANSI 150	6	95	6"150	8"150	WCB	20Cr13	20Cr13	50CrVA	316L	气体 Gas, 液体 Liquid	300	0.25	215	220
SFWA-44C150C4	ANSI 150	6	125	6"150	8"150	WCB	20Cr13	20Cr13	50CrVA	316L	气体 Gas, 液体 Liquid	300	0.25	241	240
SFWA-42C300C2	ANSI 300	6	100	6"300	6"150	WCB	20Cr13	20Cr13	50CrVA	316L	气体 Gas, 液体 Liquid	300	0.4	241	240
SFWA-44C300C1	ANSI 300	6	110	6"300	8"150	WCB	20Cr13	20Cr13	50CrVA	316L	气体 Gas, 液体 Liquid	300	0.4	241	240
SFWA-42C150C3	ANSI 150	8	150	8"150	10"150	WCB	20Cr13	20Cr13	50CrVA	316L	气体 Gas, 液体 Liquid	300	0.25	279	276
SFWA-44C150C1	ANSI 150	8	155	8"150	10"150	WCB	20Cr13	20Cr13	50CrVA	316L	气体 Gas, 液体 Liquid	300	0.25	279	276
SFWA-44C150C2	ANSI 150	8	155	8"150	12"150	WCB	20Cr13	20Cr13	50CrVA	316L	气体 Gas, 液体 Liquid	300	0.25	265	290
SFWA-44C150C1	ANSI 150	12	220	12"150	16"150	WCB	20Cr13	20Cr13	50CrVA	316L	气体 Gas, 液体 Liquid	300	0.2	335	370

API526系列安全阀 API526 Series Products

弹簧全启式安全阀 SFA-42C Spring Loaded Full Lift Safety Valve SFA-42C

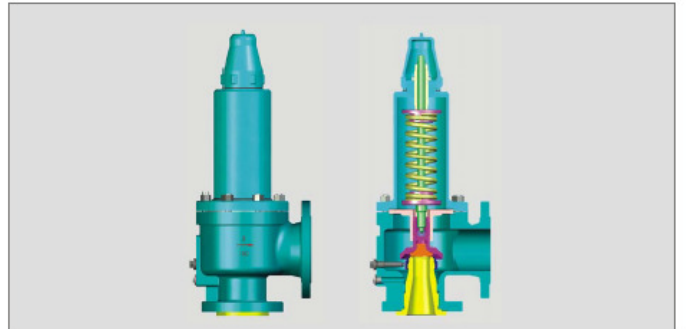

性能规范 Performance Specifications											
公称直径 Nominal Diameter DN (mm)	公称压力 Nominal Pressure CL	强度试验压力 Shell Test Ph	设定压力 Set Pressure Ps	性能指标 Performance Indicators				开启高度 Lift Height h (mm)	额定容量 Rated Capacity System	适用介质 Applicable Medium	适用温度 Applicable Temperature t
				整定压力 Set Pressure Po	超压压力 Overpressure Po	回座压力 Blowdown Po1	密封试验压力 Closure Test Pt				
3 (80)	150	2.9	0.04-0.06	0.04	0.06	≤0.03	Ps-0.03	≥10	0.8	气体等	≤300
				0.16-0.20	0.20						
				0.20-0.25	0.25						
				0.25-0.30	0.3						
				0.3-0.4	0.3						
				0.4-0.5	0.4						
				0.5-0.6	0.5						
				0.6-0.7	0.6						
				0.7-0.8	0.7						
				0.8-1.0	0.8						
				1.0-1.3	1.0						
				1.3-1.6	1.3						

API526系列安全阀API526 Series Products

弹簧全启式安全阀

Open bonnet spring loaded full lift with lever safety valve

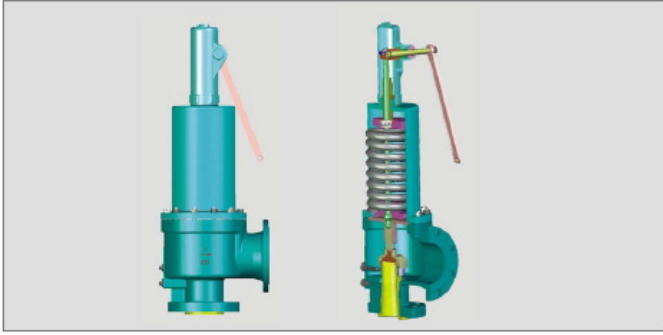

性能规范 Performance Specifications											
公称通径 Nominal Diameter DN In (mm)	公称压力 Nominal Pressure CL	强度试验 壳压力 Shell Test PS	额定压力 Set Pressure Test	性能指标 Performance Indicators				开启高度 Lift Height h mm	额定排量 Series Rated Capacity System	适用介质 Applicable Medium	适用温度 Applicable Temperature °C
				额定压力 Set Pressure PS Mpa	超过压力 Overpressure Po Mpa	总排量 Blowdown Pd1	密封试验压力 Coocure Test PT				
4 (100)	600	15.4	2.5-3.2	2.5	≤10%Ps	≤10%Ps	2.25	≥18.8	0.8	气体等 Gas	≤300
				3.2			2.88				
			3.2-4.0	3.2	2.88						
				4.0	3.60						
			4.0-5.0	4.0	3.60						
				5.0	4.50						
	5.0	4.50									
	6.4	5.76									
	5.0-6.4	6.4	5.76								
		7.0	6.30								

先导式系列安全阀Pilot Operated Safety Valve

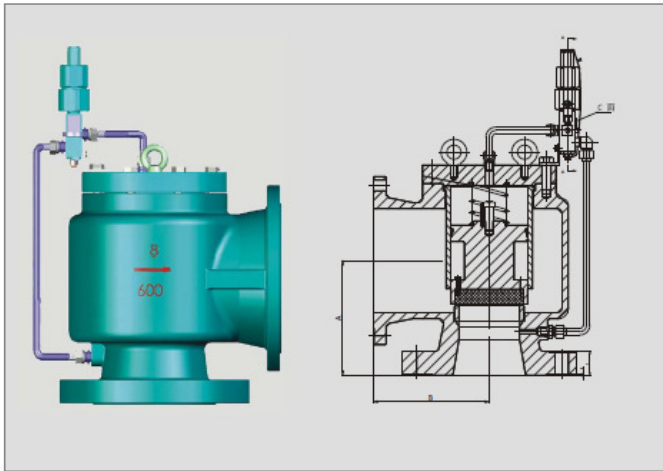

参数表Specification

进口 × 出口 Inlet × Outlet	法兰等级 ANSI Flange Rating	型号 Model Number	最大设定压力 (bar) Max. set pressure			最大出口压力 (bar) Max. Outlet pressure	阀体材料 Body Materials	代号 code name symbol						
			-26.8 -29.3	-29.3 -38.1	26.0			38.1	A _{in}	B _{in}	C	T	E	
8T10	150 150	15	19.7	11.7	19.7	19.7	碳钢 C.St. WCB	276	279	44	16			
8T10	300 150	30	51.0	41.4	19.7	19.7		276	279	58	16			
8T10	600 150	60	62.1	62.1	19.7	19.7		297	279	88	24			
8T10	150 150	15	19	19.0	11.7	19.0	奥氏体不锈钢 St.St. CF8M	276	279	44	16			
8T10	300 150	30	49.6	49.6	33.1	19.0		276	279	88	16			
8T10	600 150	60	61	60.0	60.0	19.0		297	279	88	24			
8T10	150 150	15	9.7	9.7	19.0	19.0	镍/铜合金 Alloy STM35-1	276	279	44	16			
8T10	300 150	30	24.8	24.8	19.0	19.0		276	279	58	16			
8T10	600 150	60	49.6	49.6	19.0	19.0		297	279	88	24			
8T10	150 150	15	15.9	12.4	19.0	19.0	20号合金 alloy St. CNTM	276	279	44	16			
8T10	300 150	30	41.4	32.1	19.0	19.0		276	279	58	16			
8T10	600 150	60	82.7	64.1	19.0	19.0		297	279	88	24			

(1) 温度高于38°C时的最大出口压力应不超过ANSI/ASME B16.34中规定的额定值。
Maximum back pressure limit at 38°C, for higher temperatures, shall not be above rated values of ANSI/ASME B16.34.

API526系列安全阀API526 Series Products

弹簧全启式安全阀

Open bonnet spring loaded full lift with lever safety valve

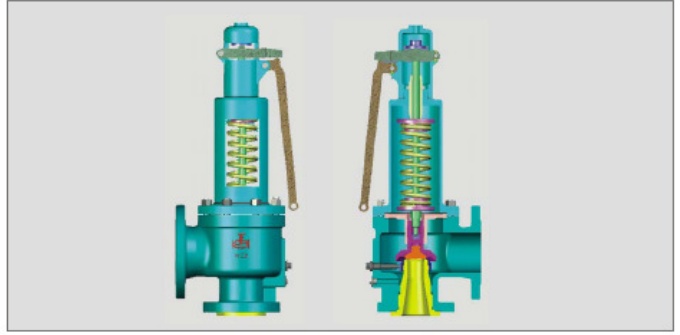

性能规范 Performance Specifications												
公称通径 Nominal Diameter DN In (mm)	公称压力 Nominal Pressure CL	强度试验 壳压力 Shell Test PS	额定压力 Set Pressure Test	性能指标 Performance Indicators				开启高度 Lift Height h mm	额定排量 Series Rated Capacity System	适用介质 Applicable Medium	适用温度 Applicable Temperature °C	
				额定压力 Set Pressure PS Mpa	超过压力 Overpressure Po Mpa	总排量 Blowdown Pd1	密封试验压力 Coocure Test PT					
3 (80)	150	3.0	0.08-0.1	0.08	≤10%Ps	Ps-0.03	0.1	≥12.5	0.8	蒸汽 Steam	≤350	
				0.1								
				0.1-0.13			0.13					
				0.13-0.16			0.16					
				0.16-0.2			0.2					
				0.2-0.25			0.25					
			0.25-0.3	0.3								
			0.3-0.4	0.4								
			0.4-0.5	0.5								
			0.5-0.6	0.6								
			0.6-0.7	0.7								
			0.7-0.8	0.8								
	0.8-1.0	1.0										
	1.0-1.3	1.3										
	1.3-1.6	1.6										
	300	6.0	15.4	0.08-0.1	0.08	≤10%Ps	Ps-0.03	0.1	≥12.5	0.8	蒸汽 Steam	≤350
					0.1							
					0.1-0.13			0.13				
					0.13-0.16			0.16				
					0.16-0.2			0.2				
					0.2-0.25			0.25				
				0.25-0.3	0.3							
				0.3-0.4	0.4							
				0.4-0.5	0.5							
0.5-0.6				0.6								
0.6-0.7				0.7								
0.7-0.8				0.8								
0.8-1.0	1.0											
1.0-1.3	1.3											
1.3-1.6	1.6											

先导式系列安全阀Pilot Operated Safety Valve

参数表Specification

进口 × 出口 Inlet × Outlet	法兰等级 ANSI Flange Rating	型号 Model Number	最大设定压力 (bar) Max. set pressure			最大出口压力 (bar) Max. Outlet pressure	阀体材料 Body Materials	代号 code name symbol					
			-26.8 -29.3	-29.3 -38.1	26.0			38.1	A _{in}	B _{in}	C	T	E
1 1/2G3	150 150	15	19.7	11.7	19.7	19.7	碳钢 C.St. WCB	130	124	31	10		
1 1/2G3	300 150	30	51.0	41.4	19.7	19.7		130	124	31	10		
1 1/2G3	600 150	60	102.0	82.7	19.7	19.7		136	124	39	16		
1 1/2G3	900 300	90	153.1	123.8	51.0	51.0		162	171				
1 1/2G3	1500 300	150	255.5	206.5	51.0	51.0		162	171				
1 1/2G3	2500 300	250	425.4	344.1	51.0	51.0		162	171				
2G3	150 150	15	19.7	11.7	19.7	19.7		136	124	35	16		
2G3	300 150	30	51.0	41.4	19.7	19.7		136	124	39	16		
2G3	600 150	60	102.0	82.7	19.7	19.7		136	124	49	16		
2G3	900 300	90	153.1	123.8	51.0	51.0		167	171				
2G3	1500 300	150	255.5	206.5	51.0	51.0		167	171				
2G3	2500 300	250	425.4	344.1	51.0	51.0		178	171				
1 1/2G3	150 150	15	19.0	11.7	19.0	19.0	130	124	31	10			
1 1/2G3	300 150	30	49.6	33.1	19.0	19.0	130	124	31	10			
1 1/2G3	600 150	60	99.3	65.8	19.0	19.0	130	124	33	10			
1 1/2G3	900 300	90	148.9	96.9	49.6	49.6	162	171					
1 1/2G3	1500 300	150	248.2	164.8	49.6	49.6	162	171					
1 1/2G3	2500 300	250	413.7	274.4	49.6	49.6	162	171					
2G3	150 150	15	19.0	11.7	19.0	19.0	136	124	35	16			
2G3	300 150	30	49.6	33.1	19.0	19.0	136	124	39	16			
2G3	600 150	60	99.3	65.8	19.0	19.0	136	124	49	16			
2G3	900 300	90	148.9	96.9	49.6	49.6	167	171					
2G3	1500 300	150	248.2	164.8	49.6	49.6	167	171					
2G3	2500 300	250	413.7	274.4	49.6	49.6	178	171					
1G2	150 150	15	9.7	9.7	19.0	19.0	105	114	46	28			
1G2	300 150	30	49.6	33.1	19.0	19.0	111	114	46	28			
1G2	600 150	60	99.3	65.8	19.0	19.0	111	114	53	28			
1G2	900 300	90	148.9	96.9	49.6	49.6	125	121	63	28			
1G2	1500 300	150	248.2	164.8	49.6	49.6	125	121	63	28			
1G2	2500 300	250	413.7	274.4	49.6	49.6	125	121	70	28			
1 1/2G2	150 150	15	9.7	9.7	19.0	19.0	124	121	49	28			
1 1/2G2	300 150	30	24.8	24.8	19.0	19.0	124	121	49	28			
1 1/2G2	600 150	60	49.6	49.6	19.0	19.0	124	121	58	28			
1 1/2G2	900 300	90	74.5	74.5	49.6	49.6	149	140	67	28			
1 1/2G2	1500 300	150	124.1	124.1	49.6	49.6	149	140	67	28			
1 1/2G2	2500 300	250	206.9	206.9	49.6	49.6	149	140	80	28			
1G2	150 150	15	15.9	12.4	19.0	19.0	105	114	46	28			
1G2	300 150	30	41.4	32.1	19.0	19.0	111	114	46	28			
1G2	600 150	60	82.7	64.1	19.0	19.0	111	114	53	28			
1G2	900 300	90	124.1	96.2	49.6	49.6	125	121	63	28			
1G2	1500 300	150	206.9	160.7	49.6	49.6	125	121	63	28			
1G2	2500 300	250	344.8	267.5	49.6	49.6	125	121	70	28			
1 1/2G2	150 150	15	15.9	12.4	19.0	19.0	124	121	49	28			
1 1/2G2	300 150	30	41.4	32.1	19.0	19.0	124	121	49	28			
1 1/2G2	600 150	60	82.7	64.1	19.0	19.0	124	121	58	28			
1 1/2G2	900 300	90	124.1	96.2	49.6	49.6	149	140	67	28			
1 1/2G2	1500 300	150	206.9	160.7	49.6	49.6	149	140	67	28			
1 1/2G2	2500 300	250	344.8	267.5	49.6	49.6	149	140	80	28			

(1) 温度高于38°C时的最大出口压力应不超过ANSI/ASME B16.34中规定的额定值。
Maximum back pressure limit at 38°C, for higher temperatures, shall not be above rated values of ANSI/ASME B16.34.

先导式系列安全阀 Pilot Operated Safety Valve

参数表 Specification

进口 × 喉径 × 出口 Inlet × Orifice × Outlet	法兰等级 ANSI Flange Rating		型号 Model	最大设定压力 (bar) Max. set pressure				最大出口压力 (bar) _m Max. Outlet pressure					阀体材料 Body Materials	代号 code name symbol				
	进口 Inlet	出口 Outlet		-268 -29	-29 -38	260	38	A ₀₁	B ₀₁	C	T	E						
1D2 150 150 15	150	150	15	19.7	11.7	19.7	19.7	105	114	46	28	碳钢 C.St. WCB	105	114	46	28		
1D2 300 150 30	300	150	30	51.0	41.4	19.7	19.7	111	114	46	28		111	114	46	28		
1D2 600 150 60	600	150	60	102.0	82.7	19.7	19.7	125	121	63	28		125	121	63	28		
1D2 1500 300 150	1500	300	150	255.5	206.5	51.0	51.0	125	121	63	28		125	121	63	28		
1D2 2500 300 250	2500	300	250	425.4	344.1	51.0	51.0	125	121	70	28		125	121	70	28		
1 1/2D2 150 150 15	150	150	15	19.7	11.7	19.7	19.7	124	121	49	28		124	121	49	28		
1 1/2D2 300 150 30	300	150	30	51.0	41.4	19.7	19.7	124	121	49	28		124	121	49	28		
1 1/2D2 600 150 60	600	150	60	102.0	82.7	19.7	19.7	124	121	58	28		124	121	58	28		
1 1/2D2 900 300 90	900	300	90	153.1	123.8	51.0	51.0	149	140	67	28		149	140	67	28		
1 1/2D2 1500 300 150	1500	300	150	255.5	206.5	51.0	51.0	149	140	67	28		149	140	67	28		
1 1/2D2 2500 300 250	2500	300	250	425.4	344.1	51.0	51.0	149	140	60	28		149	140	60	28		
1D2 150 150 15	150	150	15	19.0	11.7	19.0	19.0	105	114	46	28		105	114	46	28		
1D2 300 150 30	300	150	30	49.6	33.1	19.0	19.0	111	114	46	28		111	114	46	28		
1D2 600 150 60	600	150	60	99.3	65.8	19.0	19.0	111	114	53	28		111	114	53	28		
1D2 900 300 90	900	300	90	148.9	98.9	49.6	49.6	125	121	63	28		125	121	63	28		
1D2 1500 300 150	1500	300	150	248.2	164.8	49.6	49.6	125	121	63	28		125	121	63	28		
1D2 2500 300 250	2500	300	250	413.7	274.4	49.6	49.6	125	121	70	28		125	121	70	28		
1 1/2D2 150 150 15	150	150	15	19.0	11.7	19.0	19.0	124	121	49	28		124	121	49	28		
1 1/2D2 300 150 30	300	150	30	49.6	33.1	19.0	19.0	124	121	49	28		124	121	49	28		
1 1/2D2 600 150 60	600	150	60	99.3	65.8	19.0	19.0	124	121	58	28		124	121	58	28		
1 1/2D2 900 300 90	900	300	90	148.9	98.9	49.6	49.6	149	140	67	28		149	140	67	28		
1 1/2D2 1500 300 150	1500	300	150	248.2	164.8	49.6	49.6	149	140	67	28		149	140	67	28		
1 1/2D2 2500 300 250	2500	300	250	413.7	274.4	49.6	49.6	149	140	80	28		149	140	80	28		
1D2 150 150 15	150	150	15	9.7	9.7	19.0	19.0	105	114	46	28		105	114	46	28		
1D2 300 150 30	300	150	30	49.6	24.8	19.0	19.0	111	114	46	28	111	114	46	28			
1D2 600 150 60	600	150	60	99.3	49.6	19.0	19.0	111	114	53	28	111	114	53	28			
1D2 900 300 90	900	300	90	148.9	74.5	49.6	49.6	125	121	63	28	125	121	63	28			
1D2 1500 300 150	1500	300	150	248.2	124.1	49.6	49.6	125	121	63	28	125	121	63	28			
1D2 2500 300 250	2500	300	250	413.7	206.9	49.6	49.6	125	121	70	28	125	121	70	28			
1 1/2D2 150 150 15	150	150	15	9.7	9.7	19.0	19.0	124	121	49	28	124	121	49	28			
1 1/2D2 300 150 30	300	150	30	24.8	24.8	19.0	19.0	124	121	49	28	124	121	49	28			
1 1/2D2 600 150 60	600	150	60	49.6	49.6	19.0	19.0	124	121	58	28	124	121	58	28			
1 1/2D2 900 300 90	900	300	90	74.5	74.5	49.6	49.6	149	140	67	28	149	140	67	28			
1 1/2D2 1500 300 150	1500	300	150	124.1	124.1	49.6	49.6	149	140	67	28	149	140	67	28			
1 1/2D2 2500 300 250	2500	300	250	206.9	206.9	49.6	49.6	149	140	80	28	149	140	80	28			
1D2 150 150 15	150	150	15	15.9	12.4	19.0	19.0	105	114	46	28	105	114	46	28			
1D2 300 150 30	300	150	30	41.4	32.1	19.0	19.0	111	114	46	28	111	114	46	28			
1D2 600 150 60	600	150	60	82.7	64.1	19.0	19.0	111	114	53	28	111	114	53	28			
1D2 900 300 90	900	300	90	124.1	96.2	49.6	49.6	125	121	63	28	125	121	63	28			
1D2 1500 300 150	1500	300	150	206.9	160.7	49.6	49.6	125	121	63	28	125	121	63	28			
1D2 2500 300 250	2500	300	250	344.8	267.5	49.6	49.6	125	121	70	28	125	121	70	28			
1 1/2D2 150 150 15	150	150	15	15.9	12.4	19.0	19.0	124	121	49	28	124	121	49	28			
1 1/2D2 300 150 30	300	150	30	41.4	32.1	19.0	19.0	124	121	49	28	124	121	49	28			
1 1/2D2 600 150 60	600	150	60	82.7	64.1	19.0	19.0	124	121	58	28	124	121	58	28			
1 1/2D2 900 300 90	900	300	90	124.1	96.2	49.6	49.6	149	140	67	28	149	140	67	28			
1 1/2D2 1500 300 150	1500	300	150	206.9	160.7	49.6	49.6	149	140	67	28	149	140	67	28			
1 1/2D2 2500 300 250	2500	300	250	344.8	267.5	49.6	49.6	149	140	80	28	149	140	80	28			

(1) 温度高于 38°C 时的最大出口压力应不超过 ANSI/ASME B16.34 中规定的额定值。
Maximum back pressure limit at 38°C, for higher temperatures, shall not be above rated values of ANSI/ASME B16.34.

先导式系列安全阀 Pilot Operated Safety Valve

参数表 Specification

进口 × 喉径 × 出口 Inlet × Orifice × Outlet	法兰等级 ANSI Flange Rating		型号 Model	最大设定压力 (bar) Max. set pressure				最大出口压力 (bar) _m Max. Outlet pressure					阀体材料 Body Materials	代号 code name symbol				
	进口 Inlet	出口 Outlet		-268 -29	-29 -38	260	38	A ₀₁	B ₀₁	C	T	E						
2J3 150 150 15	150	150	15	19.7	11.7	19.7	19.7	136	124	37	18	碳钢 C.St. WCB	136	124	37	18		
2J3 300 150 30	300	150	30	51.0	41.4	19.7	19.7	136	124	41	18		136	124	41	18		
2J3 600 150 60	600	150	60	102.0	82.7	19.7	19.7	136	124	51	18		136	124	51	18		
2J3 900 300 90	900	300	90	153.1	123.8	51.0	51.0	167	171	63	20		167	171	63	20		
2J3 1500 300 150	1500	300	150	255.5	206.5	51.0	51.0	167	171	63	20		167	171	63	20		
2J3 2500 300 250	2500	300	250	425.4	344.1	51.0	51.0	178	171	63	20		178	171	63	20		
3J4 150 150 15	150	150	15	19.7	11.7	19.7	19.7	156	162	39	20		156	162	39	20		
3J4 300 150 30	300	150	30	51.0	41.4	19.7	19.7	156	162	43	20		156	162	43	20		
3J4 600 150 60	600	150	60	102.0	82.7	19.7	19.7	162	162	53	20		162	162	53	20		
3J4 900 300 90	900	300	90	153.1	123.8	51.0	51.0	190	181	63	20		190	181	63	20		
3J4 1500 300 150	1500	300	150	255.5	206.5	51.0	51.0	190	181	63	20		190	181	63	20		
2J3 150 150 15	150	150	15	19	11.7	19.0	19.0	136	124	37	18		136	124	37	18		
2J3 300 150 30	300	150	30	49.6	33.1	19.0	19.0	136	124	41	18		136	124	41	18		
2J3 600 150 60	600	150	60	99.3	65.8	19.0	19.0	136	124	51	18		136	124	51	18		
2J3 900 300 90	900	300	90	148.9	98.9	49.6	49.6	167	171	63	20		167	171	63	20		
2J3 1500 300 150	1500	300	150	244.8	164.8	49.6	49.6	167	171	63	20		167	171	63	20		
2J3 2500 300 250	2500	300	250	244.8	244.8	49.6	49.6	178	171	63	20		178	171	63	20		
3J4 150 150 15	150	150	15	19	11.7	19.0	19.0	156	162	39	20		156	162	39	20		
3J4 300 150 30	300	150	30	49.6	33.1	19.0	19.0	156	162	43	20		156	162	43	20		
3J4 600 150 60	600	150	60	99.3	65.8	19.0	19.0	162	162	53	20		162	162	53	20		
3J4 900 300 90	900	300	90	148.9	98.9	49.6	49.6	190	181	63	20		190	181	63	20		
3J4 1500 300 150	1500	300	150	248.2	164.8	49.6	49.6	190	181	63	20		190	181	63	20		
2J3 150 150 15	150	150	15	9.7	9.7	19.0	19.0	136	124	37	18		136	124	37	18		
2J3 300 150 30	300	150	30	24.8	24.8	19.0	19.0	136	124	41	18		136	124	41	18		
2J3 600 150 60	600	150	60	49.6	49.6	19.0	19.0	136	124	51	18	136	124	51	18			
2J3 900 300 90	900	300	90	74.5	74.5	49.6	49.6	167	171	63	20	167	171	63	20			
2J3 1500 300 150	1500	300	150	124.1	124.1	49.6	49.6	167	171	63	20	167	171	63	20			
2J3 2500 300 250	2500	300	250	206.9	206.9	49.6	49.6	178	171	63	20	178	171	63	20			
3J4 150 150 15	150	150	15	9.7	9.7	19.0	19.0	156	162	39	20	156	162	39	20			
3J4 300 150 30	300	150	30	24.8	24.8	19.0	19.0	156	162	43	20	156	162	43	20			
3J4 600 150 60	600	150	60	49.6	49.6	19.0	19.0	162	162	53	20	162	162	53	20			
3J4 900 300 90	900	300	90	74.5	74.5	49.6												

先导式系列安全阀 Pilot Operated Safety Valve

参数表 Specification

进口 × 喉径 × 出口 Inlet × Orifice × Outlet	法兰等级 ANSI Flange Rating		型号中 出口压力 等级 Model Number	最大设定压力 (bar) Max.set pressure			最大出口压力 (bar) _m Max.Outlet pressure	阀体材料 Body Materials	代号 code name symbol					
	进口 Inlet	出口 Outlet		-26.8 -29	-29 -38	260			38	A _m	B _m	C	T	E
3L4	150	150	15	19.7	11.7	19.7	19.0	碳钢 C.St. WCB	156	162		39	20	
3L4	300	150	30	51.0	41.4	19.7	19.0		156	162		43	20	
3L4	600	150	60	85.5	82.7	19.7	19.0		162	162		53	20	
3L4	900	300	90	153.1	123.8	51.0	19.0		190	181				
3L4	1500	300	150	200.0	200.0	51.0	19.0		190	181				
4L6	150	150	15	19.7	11.7	19.7	19.0		197	210		41	22	
4L6	300	150	30	51.0	41.4	19.7	19.0		197	210		45	22	
4L6	600	150	60	102.0	82.7	19.7	19.0		197	210		55	22	
4L6	900	300	90	153.1	123.8	51.0	19.0		249	233				
4L6	1500	300	150	255.5	206.5	51.0	19.0		249	233				
3L4	150	150	15	19.0	19.0	11.7	19.0		奥氏体不锈钢 St.St. CF8M	156	162		39	20
3L4	300	150	30	49.6	49.6	33.1	19.0			156	162		43	20
3L4	600	150	60	82.7	82.7	65.8	19.0	162		162		53	20	
3L4	900	300	90	148.9	148.9	98.9	49.6	190		181				
3L4	1500	300	150	194.8	194.8	164.8	49.6	190		181				
4L6	150	150	15	19.0	19.0	11.7	19.0	197		210		41	22	
4L6	300	150	30	49.6	49.6	33.1	19.0	197		210		45	22	
4L6	600	150	60	99.3	99.3	65.8	19.0	197		210		55	22	
4L6	900	300	90	148.9	148.9	98.9	49.6	249		233				
4L6	1500	300	150	248.2	248.2	164.8	49.6	249		233				
3L4	150	150	15	9.7	9.7	19.0	19.0	镍/铝合金 Alloy SLM35-1		156	162		39	20
3L4	300	150	30	24.8	24.8	19.0	19.0			156	162		43	20
3L4	600	150	60	49.6	49.6	19.0	19.0		162	162		53	20	
3L4	900	300	90	74.5	74.5	49.6	19.0		190	181				
3L4	1500	300	150	124.1	124.1	49.6	19.0		190	181				
4L6	150	150	15	9.7	9.7	19.0	19.0		197	210		41	22	
4L6	300	150	30	24.8	24.8	19.0	19.0		197	210		45	22	
4L6	600	150	60	49.6	49.6	19.0	19.0		197	210		55	22	
4L6	900	300	90	74.5	74.5	49.6	19.0		249	233				
4L6	1500	300	150	124.1	124.1	49.6	19.0		249	233				
3L4	150	150	15	15.9	12.4	19.0	19.0		20号合金 alloy St. CN7M	156	162		39	20
3L4	300	150	30	41.4	32.1	19.0	19.0			156	162		43	20
3L4	600	150	60	82.7	64.1	19.0	19.0	162		162		53	20	
3L4	900	300	90	124.1	96.2	49.6	19.0	190		181				
3L4	1500	300	150	206.9	160.7	49.6	19.0	190		181				
4L6	150	150	15	15.9	12.4	19.0	19.0	197		210		41	22	
4L6	300	150	30	41.4	32.1	19.0	19.0	197		210		45	22	
4L6	600	150	60	82.7	64.1	19.0	19.0	197		210		55	22	
4L6	900	300	90	124.1	96.2	49.6	19.0	249		233				
4L6	1500	300	150	206.9	160.7	49.6	19.0	249		233				

(1) 温度高于 38°C 时的最大出口压力应不超过 ANSI/ASME B16.34 中规定的额定值。
Maximum back pressure limit at 38 °C, for higher temperatures, shall not be above rated values of ANSI/ASME B16.34.

先导式系列安全阀 Pilot Operated Safety Valve

参数表 Specification

进口 × 喉径 × 出口 Inlet × Orifice × Outlet	法兰等级 ANSI Flange Rating		型号中 出口压力 等级 Model Number	最大设定压力 (bar) Max.set pressure			最大出口压力 (bar) _m Max.Outlet pressure	阀体材料 Body Materials	代号 code name symbol						
	进口 Inlet	出口 Outlet		-26.8 -29	-29 -38	260			38	A _m	B _m	C	T	E	
															°C
4M6	150	150	15	19.7	11.7	19.7	19.0	碳钢 C.St. WCB	197	210		39	20		
4M6	300	150	30	51.0	41.4	19.7	19.0		197	210		43	20		
4M6	600	150	60	102.0	82.7	19.7	19.0		197	210		53	20		
4M6	900	300	90	153.1	123.8	51.0	19.0		249	233					
4M6	1500	300	150	255.5	206.5	51.0	19.0		249	233					
4M6	150	150	15	19.0	19.0	11.7	19.0		奥氏体不锈钢 St.St. CF8M	197	210		39	20	
4M6	300	150	30	49.6	49.6	33.1	19.0			197	210		43	20	
4M6	600	150	60	99.3	99.3	65.8	19.0			197	210		53	20	
4M6	900	300	90	148.9	148.9	98.9	49.6			249	233				
4M6	1500	300	150	248.2	248.2	164.8	49.6			249	233				
4M6	150	150	15	9.7	9.7	19.0	19.0			镍/铝合金 Alloy SLM35-1	197	210		39	20
4M6	300	150	30	24.8	24.8	19.0	19.0				197	210		43	20
4M6	600	150	60	49.6	49.6	19.0	19.0	197			210		53	20	
4M6	900	300	90	74.5	74.5	49.6	19.0	249			233				
4M6	1500	300	150	124.1	124.1	49.6	19.0	249			233				
4M6	150	150	15	15.9	12.4	19.0	19.0	20号合金 alloy St. CN7M			197	210		39	20
4M6	300	150	30	41.4	32.1	19.0	19.0				197	210		43	20
4M6	600	150	60	82.7	64.1	19.0	19.0		197		210		53	20	
4M6	900	300	90	124.1	96.2	49.6	19.0		249		233				
4M6	1500	300	150	206.9	160.7	49.6	19.0		249		233				

(1) 温度高于 38°C 时的最大出口压力应不超过 ANSI/ASME B16.34 中规定的额定值。
Maximum back pressure limit at 38 °C, for higher temperatures, shall not be above rated values of ANSI/ASME B16.34.

先导式系列安全阀 Pilot Operated Safety Valve

参数表 Specification

进口 × 喉径 × 出口 Inlet × Orifice × Outlet	法兰等级 ANSI Flange Rating		型号中 出口压力 等级 Model Number	最大设定压力 (bar) Max.set pressure			最大出口压力 (bar) _m Max.Outlet pressure	阀体材料 Body Materials	代号 code name symbol						
	进口 Inlet	出口 Outlet		-26.8 -29	-29 -38	260			38	A _m	B _m	C	T	E	
															°C
4N6	150	150	15	19.7	11.7	19.7	19.0	碳钢 C.St. WCB	197	210		39	20		
4N6	300	150	30	51.0	41.4	19.7	19.0		197	210		43	20		
4N6	600	150	60	102.0	82.7	19.7	19.0		197	210		53	20		
4N6	900	300	90	153.1	123.8	51.0	19.0		249	233					
4N6	1500	300	150	255.5	206.5	51.0	19.0		249	233					
4N6	150	150	15	19.0	19.0	11.7	19.0		奥氏体不锈钢 St.St. CF8M	197	210		39	20	
4N6	300	150	30	49.6	49.6	33.1	19.0			197	210		43	20	
4N6	600	150	60	99.3	99.3	65.8	19.0			197	210		53	20	
4N6	900	300	90	148.9	148.9	98.9	49.6			249	233				
4N6	1500	300	150	248.2	248.2	164.8	49.6			249	233				
4N6	150	150	15	9.7	9.7	19.0	19.0			镍/铝合金 Alloy SLM35-1	197	210		39	20
4N6	300	150	30	24.8	24.8	19.0	19.0				197	210		43	20
4N6	600	150	60	49.6	49.6	19.0	19.0	197			210		53	20	
4N6	900	300	90	74.5	74.5	49.6	19.0	249			233				
4N6	1500	300	150	124.1	124.1	49.6	19.0	249			233				
4N6	150	150	15	15.9	12.4	19.0	19.0	20号合金 alloy St. CN7M			197	210		39	20
4N6	300	150	30	41.4	32.1	19.0	19.0				197	210		43	20
4N6	600	150	60	82.7	64.1	19.0	19.0		197		210		53	20	
4N6	900	300	90	124.1	96.2	49.6	19.0		249		233				
4N6	1500	300	150	206.9	160.7	49.6	19.0		249		233				

(1) 温度高于 38°C 时的最大出口压力应不超过 ANSI/ASME B16.34 中规定的额定值。
Maximum back pressure limit at 38 °C, for higher temperatures, shall not be above rated values of ANSI/ASME B16.34.

先导式系列安全阀 Pilot Operated Safety Valve

参数表 Specification

进口 × 喉径 × 出口 Inlet × Orifice × Outlet	法兰等级 ANSI Flange Rating		型号中 出口压力 等级 Model Number	最大设定压力 (bar) Max.set pressure			最大出口压力 (bar) _m Max.Outlet pressure	阀体材料 Body Materials	代号 code name symbol					
	进口 Inlet	出口 Outlet		-26.8 -29	-29 -38	260			38	A _m	B _m	C	T	E
4P6	150	150	15	19.7	11.7	19.7	19.0	碳钢 C.St. WCB	197	210		39	20	
4P6	300	150	30	51.0	41.4	19.7	19.0		197	210		43	20	
4P6	600	150	60	102.0</										

先导式系列安全阀 Pilot Operated Safety Valve

参数表 Specification

进口 × 喉径 × 出口 Inlet × Orifice × Outlet	法兰等级 ANSI Flange Rating		型号 × 口径 × 力等级 Model Number	最大设定压力 (bar) Max. set pressure				筒体材料 Body Materials	代号 code name symbol				
	进口 Inlet	出口 Outlet		-268℃ --29℃	-29℃ -38℃	260℃	38℃		A ₀₀	B ₀₀	C	T	E
6Q8	150	150	15		19.7	11.7	19.7	碳钢 C.St. WCB	240	241		40	14
6Q8	300	150	30		51.0	41.4	19.7		240	241		51	14
6Q8	600	150	60		91.7	82.7	19.7		246	241		75	20
6Q8	600	300	60a		102.0	82.7	51.0		246	265		75	20
6Q8	150	150	15	19.0	19.0	11.7	19.0	奥氏体不锈钢 St.St. CF8M	240	241		40	14
6Q8	300	150	30	49.6	49.6	33.1	19.0		240	241		51	14
6Q8	600	150	60	88.6	88.6	65.8	19.0		246	241		75	20
6Q8	600	300	60a	99.3	99.3	65.8	49.6		246	265		75	20
6Q8	150	150	15		9.7	9.7	19.0	镍/铝合金 Alloy SLM35-1	240	241		40	14
6Q8	300	150	30		24.8	24.8	19.0		240	241		51	14
6Q8	600	150	60		49.6	49.6	19.0		246	241		75	20
6Q8	600	300	60a		49.6	49.6	49.6		246	265		75	20
6Q8	150	150	15		15.9	12.4	19.0	20号合金 alloy St. CN7M	240	241		40	14
6Q8	300	150	30		41.4	32.1	19.0		240	241		51	14
6Q8	600	150	60		82.7	64.1	19.0		246	241		75	20
6Q8	600	300	60a		82.7	64.1	49.6		246	265		75	20

(1) 温度高于38℃时的最大出口压力应不超过ANSI/ASME B16.34中规定的额定值。
Maximum back pressure limit at 38℃, for higher temperatures, shall not be above rated values of ANSI/ASME B16.34.
(2) A和B的公差为 ±1.6, Tolerances for A and B: ±1.6

参数表 Specification

进口 × 喉径 × 出口 Inlet × Orifice × Outlet	法兰等级 ANSI Flange Rating		型号 × 口径 × 力等级 Model Number	最大设定压力 (bar) Max. set pressure				筒体材料 Body Materials	代号 code name symbol				
	进口 Inlet	出口 Outlet		-268℃ --29℃	-29℃ -38℃	260℃	38℃		A ₀₀	B ₀₀	C	T	E
6R8	150	150	15		19.7	11.7	19.7	碳钢 C.St. WCB	240	241		40	14
6R8	300	150	30		51.0	42.4	19.7		240	241		51	14
6R8	600	150	60		63.1	63.1	19.7		246	241		75	20
6R8	150	150	15	19.0	19.0	11.7	19.0		240	241		40	14
6R8	300	150	30	19.0	49.6	33.1	19.0	奥氏体不锈钢 St.St. CF8M	240	241		51	14
6R8	600	150	60	49.6	61.0	61.0	19.0		246	241		75	20
6R8	150	150	15	61.0	9.7	9.7	19.0		240	241		40	14
6R8	300	150	30		24.8	24.8	19.0		240	241		51	14
6R8	600	150	60		49.6	49.6	19.0	镍/铝合金 Alloy SLM35-1	246	241		75	20
6R8	150	150	15		15.9	12.4	19.0		240	241		40	14
6R8	300	150	30		41.4	32.1	19.0		240	241		51	14
6R8	600	150	60		82.7	64.1	19.0		246	241		75	20

(1) 温度高于38℃时的最大出口压力应不超过ANSI/ASME B16.34中规定的额定值。
Maximum back pressure limit at 38℃, for higher temperatures, shall not be above rated values of ANSI/ASME B16.34.

先导式系列安全阀 Pilot Operated Safety Valve

参数表 Specification

进口 × 喉径 × 出口 Inlet × Orifice × Outlet	法兰等级 ANSI Flange Rating		型号 × 口径 × 力等级 Model Number	最大设定压力 (bar) Max. set pressure				筒体材料 Body Materials	代号 code name symbol				
	进口 Inlet	出口 Outlet		-268℃ --29℃	-29℃ -38℃	260℃	38℃		A ₀₀	B ₀₀	C	T	E
1F2	150	150	15		19.7	11.7	19.7	碳钢 C.St. WCB	105	114		46	28
1F2	300	150	30		51.0	41.4	19.7		111	114		46	28
1F2	600	150	60		102.0	82.7	19.7		111	114		53	28
1F2	900	300	90		153.1	123.8	51.0		125	121		63	28
1F2	2500	300	250		425.4	344.1	51.0	镍/铝合金 Alloy SLM35-1	125	121		70	28
1F2	150	150	15		19.7	11.7	19.7		124	121		49	28
1F2	300	150	30		51.0	41.4	19.7		124	121		49	28
1F2	600	150	60		102.0	82.7	19.7		124	121		58	28
1F2	900	300	90		153.1	123.8	51.0	奥氏体不锈钢 St.St. CF8M	149	140		67	28
1F2	1500	300	150		255.5	206.5	51.0		149	140		67	28
1F2	2500	300	250		425.4	344.1	51.0		149	140		80	28
1F2	150	150	15		19.0	11.7	19.0		105	114		46	28
1F2	300	150	30		49.6	33.1	19.0	镍/铝合金 Alloy SLM35-1	111	114		46	28
1F2	600	150	60		99.3	65.8	19.0		111	114		53	28
1F2	900	300	90		148.9	98.9	49.6		125	121		63	28
1F2	1500	300	150		248.2	164.8	49.6		125	121		63	28
1F2	150	150	15	19.0	19.0	11.7	19.0	奥氏体不锈钢 St.St. CF8M	124	121		49	28
1F2	300	150	30	49.6	49.6	33.1	19.0		124	121		49	28
1F2	600	150	60	99.3	99.3	65.8	19.0		124	121		58	28
1F2	900	300	90	148.9	148.9	98.9	49.6		124	121		67	28
1F2	1500	300	150	248.2	248.2	164.8	49.6	镍/铝合金 Alloy SLM35-1	149	140		67	28
1F2	150	150	15	15.9	12.4	19.0	19.0		149	140		67	28
1F2	300	150	30	41.4	32.1	19.0	19.0		149	140		67	28
1F2	600	150	60	82.7	64.1	19.0	19.0		149	140		67	28
1F2	900	300	90	124.1	96.2	49.6	49.6	20号合金 alloy St. CN7M	125	121		49	28
1F2	1500	300	150	206.9	150.7	49.6	49.6		125	121		53	28
1F2	2500	300	250	344.8	267.5	49.6	49.6		125	121		70	28
1F2	150	150	15	15.9	12.4	19.0	19.0		124	121		49	28
1F2	300	150	30	41.4	32.1	19.0	19.0	奥氏体不锈钢 St.St. CF8M	124	121		49	28
1F2	600	150	60	82.7	64.1	19.0	19.0		124	121		58	28
1F2	900	300	90	124.1	96.2	49.6	49.6		149	140		67	28
1F2	1500	300	150	206.9	160.7	49.6	49.6		149	140		67	28
1F2	2500	300	250	344.8	267.5	49.6	49.6	149	140		80	28	

(1) 温度高于38℃时的最大出口压力应不超过ANSI/ASME B16.34中规定的额定值。
Maximum back pressure limit at 38℃, for higher temperatures, shall not be above rated values of ANSI/ASME B16.34.

安全切换系列安全阀 Quick Crossover Safety Valve

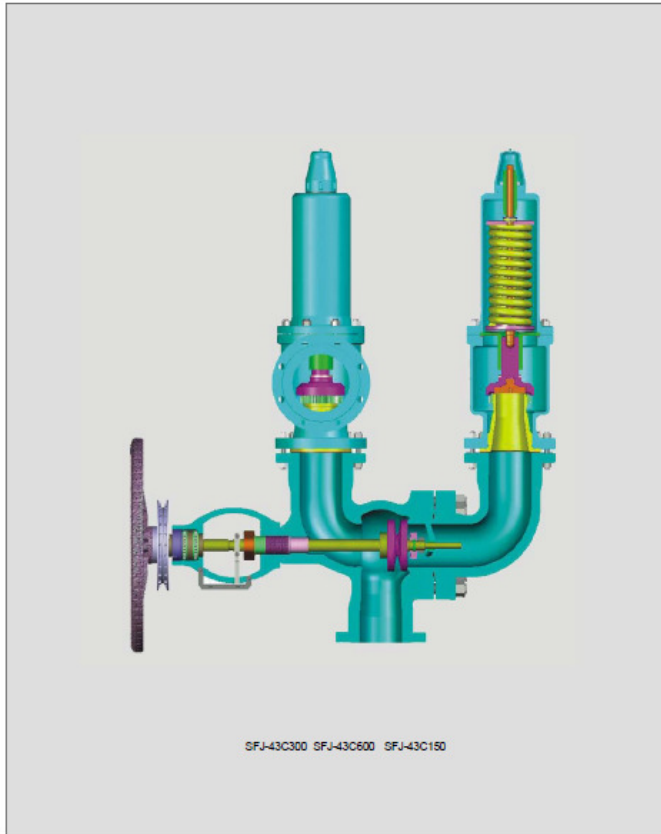

安全切换系列安全阀 Quick Crossover Safety Valve

特点

- 三通流路设计，一个工位安装两个相同的安全阀，其中一个在线进行超压保护，而另一个则作为维修备用，转向系统操作安全、简便、快捷。
- 快速切换无需装置停车，提供连续的超压保护，避免应急停车维修所带来的昂贵费用损失。
- 在每一个安全阀的下方，安装有一个泄出阀，用安全、有效的泄出待拆卸安全阀前的介质，并将其引入排放管中。
- 快速切换装置中设有平衡阀，因而操作轻便。
- 适用温度范围宽（低温至高温）。
- 密封可靠，多次动作后仍保持所需密封性。

Features

Three-way design provides dual pressure relief device system which is installed on one position, one is active for overpressure protection, the other is kept in reserve as a standby. The operation of crossover is safe, handy and fast. Process shutdown is not needed when crossover, so high cost due to unscheduled shutdown can be saved. A vent valve is provided under each safety valve, to relieve fluid out of the pipe before the isolated safety valve which is to be dismantled. Balance valve of the Quick Crossover Device Provides low actuation torque, so crossover is very handy. Applicable Temperature band is wide. Good seat tightness, even after switching many times.

序号 NO.	零部件名称 Part Name
1	切换阀 Selector Valve
2	安全阀 Safety Valve
3	平衡阀 Balance Valve
4	泄放阀 Vent Valve

- 平衡阀根据使用需要确定是否安装
- Whether balance valve should be installed or not depends on application need.

操作步骤

- 检查两路排放阀，使其处于关闭状态；
 - 打开平衡阀；
 - 转动手轮，完成切换；
 - 关闭平衡阀；
 - 打开处于备用位置的泄放阀，使这一侧安全阀前的介质排空；
 - 卸下需检修，更换的备用安全阀。
- Operation
- Check up two vent valve, they must be on closed position.
 - Open balance valve.
 - Rotate handwheel to switch.
 - Close balance valve.
 - Open vent valve on standby side, to relieve fluid out of the pipe under the standby safety valve.
 - Dismantle the standby safety valve.

制冷机用系列安全阀 Safety Valve for Refrigerator

制冷机用安全阀是用于制冷设备上，作为设备的超压保护装置，当设备运行压力升高超过允许值时，阀门能自动开启，并依照设备运行要求，排放规定量介质，以防止设备压力继续升高，起到保护整个系统作用。

上海赛门有限公司生产的SFA-22C150T/SFA-22C300T型的安全阀系列是为冷冻机冷藏器、蒸发器配套的超压保护装置，产品试验及性能符合美国ANSI B16.34、ANSI/ASHRAE 15-78及我国GB12241-12243等有关标准要求。

The valve is used for refrigeration equipment as a overpressure protective device. When the equipment system pressure goes beyond the rated pressure, the valve will consequently open and relieve the pressure down to the safety one according to the design requirement for protection of equipment.

Test and Performance Standard: ANSI B16.34, ANSI/ASHRAE 15-78/GB 12241-12243

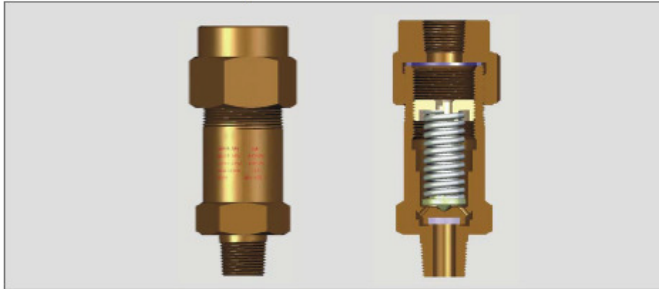

性能规范 Performance Specifications

公称直径 Nominal Diameter DN (mm)	公称压力 Nominal Pressure CL	强度试验压力 Shear Test Ph	额定压力 Set Pressure Test	性能指标 Performance Indicators			开启高度 Lift Height h mm	额定排量 Rated Capacity System	适用介质 Applicable Medium	适用温度 Applicable Temperature ℃	
				额定压力 Set Pressure Ps Mpa	超过压力 Over Pressure Po Mpa	启动压力 Blow Down Pb1 Mpa					密封试验压力 Close Test Pt Mpa
1/2 (15)	150	3.0	0.4-0.5	0.4			0.36	≥0.03	0.16	氟利昂及冷冻机油 freon freezing oil	-40~+150
				0.5			0.45				
				0.5			0.45				
				0.6			0.54				
				0.6			0.54				
				0.6-0.7			0.63				
				0.6			0.63				
				0.7			0.63				
				0.7-0.8			0.81				
				0.8			0.81				
				0.8			0.9				
				0.8-1.0			0.9				
				1.0			1.17				
				1.0-1.3			1.17				
1.3			1.44								
1.3-1.6			1.44								
1.6			1.44								
1.6-2.0			1.8								

内装式槽车用安全阀 BUILT-IN SAFETY VALVE FOR TANK WAGON

SFNA-42B25C1

结构特点 Structural Features

SFNA-42B25C1型安全阀采用内装式结构，所占空间位置极少，特别适用于槽车和罐车一类的设备上作为超压保护装置。本产品工作介质由阀瓣下泄入，多余介质直接向空间排放，调节螺母体积小，重量轻，开启压力的大小通过转动调节螺母来达到，使用和安装非常方便。

性能规范 Property Specifications

公称直径 (DN): 32, 40, 50mm
公称压力 (PN): 2.5MPa 强度试验压力 3.8MPa
工作温度 (℃): 55, 适用介质: 液化石油气
额定压力 (PK): 0.86, 1.08, 1.93, 2.37, Mpa
开启高度: > Do/4mm

SFNA-42B25C1 Type Built-in Safety Valves for Tank Wagon

Structural Features:
SFNA-42B25C1 type safety valve takes the built-in structure which occupies rather little space and is especially suited to be applied in tank wagons and the equipment of the same kind as a protecting device for overpressure.

The working medium of this product enters under the valve disc and the unnecessary medium is directly discharged to the air. The spring is fixed in the inside cavity of the valve disc, therefore it is compact in structure, small in size and light in weight. The required amount of relieving pressure is obtained by twisting the adjusting screw nut. It is quite convenient for you to operate an install it.

Nominal Diameter (DN): 32, 40, 50mm
Nominal Pressure (PN): 2.5MPa; the pressure of strength experiment: 3.8MPa
Working Temperature (℃): 55 Media available: Liquefied petroleum gas.
Set Pressure (PK): 0.86, 1.08, 1.93, 2.37MPa
Lift Height: > Do/4mm

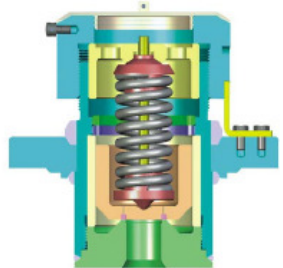

主要零部件材料

序号 No.	零件名称 Parts Name	材料 Material
1	阀座 Nozzle seat	25 (淬硬合金 Carbide hardfacing)
2	阀体 Body	20
3	阀瓣 Disc	2Cr13
4	衬套 Bushing	2Cr13
5	弹簧座 Spring Seat	35
6	弹簧 Spring	50CrVA
7	调节螺母 Adjusting nut	35

外型尺寸和链接尺寸 Dimensions (mm)

公称直径 (DN)	Do	D	K	g1	g2	g3/g4	b	f	f1	h	H	Z-φL	重量 Weight (kg)
32	25	195	160	135	120	105/100	24	3	4	≤104	~186	8-φ18	17
40	32	230	190	160	149	128/118	28	3	4.5	≤104	~215	8-φ23	20
50	40	270	220	188	175	150/138.5	30	3	4.5	≤104	~250	8-φ25	25

制冷机用系列安全阀 Safety Valve for Refrigerator

运输、安装和使用 Handling, installation and operation:

1. 运输时应避免震动，并应存放在通风干燥的室内，其进、出口应堵塞。
2. 阀门安装时必须仔细阅读阀门的标志是否与实际要求相符合。
3. 安全阀必须垂直安装，并且最好直接安装在垂直的管路上，接头内径不小于安全阀的进口直径。
4. 若安装排放管，其排放管的内径应小于安全阀的出口直径，排放管的阻力应尽可能小。
5. 安全阀全部调整完毕后，应进行铅封，以防止私自改变调整好的状态。
6. 当安全阀的额定压力调整完后，调整螺母应用粘胶剂加以固定，以防止调整好的额定压力发生变化。

主要零件材料

序号 No.	零件名称 Parts Name	材料 Material
1	阀体 Body	H62
2	阀瓣组合件 Valve assembly	H62+H-4
3	弹簧非簧座 Spring seat	1Cr13/STI
4	弹簧 Spring	50CrVA
5	调节螺母 Adjusting nut	H62
6	垫片 Gasket	T3
7	螺母 Nut	H62

主要性能参数

型号 Model	SFA-22C150T	SFA-22C300T
压力级 Pressure level	150psi	300psi
公称直径 Nominal Diameter DN	1/2"(15), 1"(25)	1/2"(15), 3/4"(20), 1"(25)
强度试验压力 Strength test pressure	3 Mpa	7.5 Mpa
排放压力 Discharge pressure	< 1.1倍额定压力	
密封压力 Sealing pressure	> 0.85倍额定压力	
密封性 Tightness	气密试验 2 分钟无泄漏	
适用温度 The application of temperature	-40℃ ~ +150℃	
适用介质 Applicable medium	R12, R22, R500等氟利昂及冷冻机油	

主要外形尺寸和性能参数

型号 Model	压力级 psi	公称直径 in(mm)	喉径 do mm	高度 H mm	进口处连接尺寸	出口处连接尺寸	排放压力 Mpa	密封压力 Mpa
SFA-22C150T	150	1/2"(15)	9.5	95	1/2"(MPT)	3/4"(FPT)		
SFA-22C150T1	150	1/2"(15)	11	115	1/2"(FPT)	1/2"(FPT)		
SFA-22C150T2	150	1/2"(15)	11	95	1/2"(FPT)	1/2"(FPT)		
SFA-22C150T3	150	1"(25)	18	145	1"(MPT)	1 1/4"(FPT)		
SFA-22C150T1	150	1"(25)	18	145	1"(MPT)	1 1/4"(FPT)		
SFA-22C150T2	150	1"(25)	18	145	1"(MPT)	1 1/4"(FPT)		
SFA-22C300T	300	1/2"(15)	6.5	92	1/2"(MPT)	7/8"(UNF)		
SFA-22C300T1	300	1/2"(15)	6.8	48	1/8"(UNF)		≤1.1Ps	≥90%Ps
SFA-22C300T	300	3/4"(20)	11	102	3/4"(MPT)	3/4"(FPT)		
SFA-22C300T1	300	3/4"(20)	9.5	95	3/4"(MPT)	3/4"(FPT)		
SFA-22C300T2	300	3/4"(20)	9.5	95	3/4"(MPT)	3/4"(FPT)		
SFA-22C300T3	300	3/4"(20)	11	102	3/4"(MPT)	3/4"(FPT)		
SFA-22C300T	300	1"(25)	18	145	1"(MPT)	1 1/4"(FPT)		
SFA-22C300T1	300	1"(25)	18	145	1"(MPT)	1 1/4"(FPT)		
SFA-22C300T2	300	1"(25)	13	105	1"(MPT)	1"(FPT)		

安全阀的选型方法 Selection of safety valve

选型 Sizing Formulas

$$\text{气体 Gas and vapor } A = W \sqrt{0.075 \times C \times K_d \times K_b \times P_d \times \left(\frac{M}{Z \times T} \right)}$$

$$\text{液体 Liquid } A = 11.78 \times Q \sqrt{K_d \times K_b \times K_v \times \left(\frac{G}{1.25 \times P_b - P_d} \right)} \quad (\text{注: 液体 } P_b \text{ 单位为 Kpa})$$

$$\text{蒸汽 Steam } A = W \sqrt{5.25 \times K_d \times P_d \times K_{sh} \times K_D}$$

符号 Nomenclature

- Wdr kg/h - 额定排量 Certified (discharge) capacity
- A mm² - 流通面积 Flow area, 见表 1 (see table 1)
- Ps MPa - 额定压力 Set pressure
- Pd MPa - 排放压力 (绝压) Relieving pressure (absolute)
- Pdr MPa - 额定排放压力 (绝压) Rated relieving pressure (absolute)
- Pb MPa - 背压 (绝压) Backpressure (absolute)
- M Kg/Kmol - 分子量 Molecular weight, 见表 2 (see table 2)
- K - 气体绝热指数 Specific heat ratio
- C - 气体特性系数 Coefficient determined by K, 见表 3 (see table 3)
- Z - 压缩系数 Compressibility factor
- TK - 绝对温度 Absolute temperature, K = °C + 273
- Wr kg/h - 所需排量 Required capacity
- Q l/min - 所需排量 Required capacity, (liquids)
- Kdr - 额定排量系数 Rated coefficient of discharge
- Kv - 粘度修正系数 Viscosity correction factor, 见表 5 (see figure 5)
- Kb - 背压修正系数 Backpressure correction factor, 见表 1-3, 表 4 (see figure 1-3/table 4)
- Kp - 超过压力系数修正系数 Over pressure correction factor, 见表 4 (see figure 4)
- G kg/m³ - 密度 Density of liquid
- Ksh - 过热修正系数 for saturated steam, 见表 5 (see table 5)

表 1 Table 1

流道口 Orifice	mm ²	in ²	dn ²
D	71.0	0.110	
E	126.5	0.196	
F	198.1	0.307	
G	324.5	0.503	
H	506.5	0.785	
J	830.3	1.287	
K	1185.8	1.838	
L	1840.6	2.853	
M	2322.6	3.600	
N	2800.0	4.340	
P	4116.1	6.380	
Q	7129.0	11.050	
R	10322.6	16.000	
T	16774.2	26.000	

附表Schedule

表2 table 2 分子量

气体 Gas	分子式 molecular formula	分子量 molecular weight	K	C
乙炔 Acetylene	C ₂ H ₂	26	1.28	345
空气 Air		29	1.40	356
氨气 Ammonia	NH ₃	17	1.33	351
氩气 Argon	Ar	40	1.66	377
苯 Benzene	C ₆ H ₆	78	1.21	338
二氧化碳 Carbon Dioxide	CO ₂	44	1.28	345
一氧化碳 Carbon Monoxide	CO	28	1.40	356
氯气 Chlorine	Cl ₂	71	1.36	352
环己烷 Cyclohexane	C ₆ H ₁₂	84	1.08	324
乙烷 Ethane	C ₂ H ₆	30	1.22	339
乙烯 Ethylene	C ₂ H ₄	28	1.20	337
氦气 Helium	He	4	1.66	377
己烷 Hexane	C ₆ H ₁₄	86	1.08	324
盐酸 Hydrochloric Acid	HCl	36.5	1.40	356
氢气 Hydrogen	H ₂	2	1.40	356
硫化氢 Hydrogen sulphide	H ₂ S	34	1.32	348
丁烷 Isobutane	C ₄ H ₁₀	58	1.11	328
甲烷 Methane	CH ₄	16	1.30	346
甲醇 Methyl Alcohol	CH ₃ OH	32	1.20	337
氯化甲 Methyl chloride	CH ₂ Cl	50.5	1.20	337
丁烷 N-Butane	C ₄ H ₁₀	58	1.11	328
天然气 Natural Gas		19	1.27	345
氮气 Nitrogen	N ₂	28	1.40	356
氧气 Oxygen	O ₂	32	1.40	356
丙烷 Propane	C ₃ H ₈	44	1.14	331
二氧化硫 Sulphur Dioxide	SO ₂	64	1.26	342
蒸汽 Water Vapor/steam	H ₂ O	18	1.30	347

表3 table 3 系数 C和K的值 Versus Gas Constant

K	C	K	C	K	C	K	C
1.00	315	1.26	343	1.52	366	1.78	386
1.01	317	1.27	344	1.53	367	1.79	386
1.02	318	1.28	345	1.54	368	1.80	387
1.03	319	1.29	346	1.55	369	1.81	388
1.04	320	1.30	347	1.56	369	1.82	389
1.05	321	1.31	348	1.57	370	1.83	389
1.06	322	1.32	349	1.58	371	1.84	390
1.07	323	1.33	350	1.59	372	1.85	391
1.08	324	1.34	351	1.60	373	1.86	391
1.09	325	1.35	352	1.61	373	1.87	392
1.10	327	1.36	353	1.62	374	1.88	393
1.11	328	1.37	353	1.63	375	1.89	393
1.12	329	1.38	354	1.64	376	1.90	394
1.13	330	1.39	355	1.65	376	1.91	395
1.14	331	1.40	356	1.66	377	1.92	395
1.15	332	1.41	357	1.67	378	1.93	396
1.16	333	1.42	358	1.68	379	1.94	397
1.17	334	1.43	359	1.69	379	1.95	397
1.18	335	1.44	360	1.70	380	1.96	398
1.19	336	1.45	360	1.71	381	1.97	398
1.20	337	1.46	361	1.72	382	1.98	399
1.21	338	1.47	362	1.73	382	1.99	400
1.22	339	1.48	363	1.74	383	2.00	400
1.23	340	1.49	364	1.75	384		
1.24	341	1.50	365	1.76	384		
1.25	342	1.51	366	1.77	385		

美标法兰标准 American Flange Standard ANSI B16.5

美标端法兰

Flange end to ASME B16.5

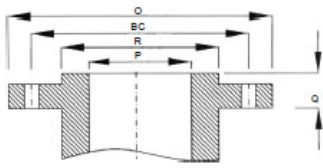

美标压力级150突面法兰

CLASS 150 RF FLANGE TO ASME B16.5

口径 NPS	法兰外径 OD of Flange " O "	螺栓中径 Diameter of Bolt Circle " BC "	突面外径 Diameter of RF " R "	阀门通道内径 Valve Port " P " >=	法兰厚度 Thickness of Flange " Q " >=	螺栓数量 Number of Bolt	螺栓内径 Diameter of Bolt Holes	螺栓外径 Diameter of Bolts
1/2	89	60.5	35	φ15	12	4	φ15	
3/4	98	70	43	φ20	12	4	φ15	
1	108	79.5	51	φ25	12	4	φ15	
1 1/4	117	89	64	φ32	13	4	φ15	
1 1/2	127	98.5	73	φ38	15	4	φ15	
2	152.4	120.7	91.9	φ50	19.1	4	φ19.1	5/8"
2 1/2	177.8	139.7	104.6	φ63	22.4	4	φ19.1	5/8"
3	190.5	152.4	127	φ76	23.9	4	φ19.1	5/8"
3 1/2	216	177.8	139.7	φ89	23.9	4	φ19.1	5/8"
4	228.6	190.5	157.2	φ100	23.9	8	φ19.1	5/8"
5	254	215.9	185.7	φ127	23.9	8	φ22.4	3/4"
6	279.4	241.3	215.9	φ150	25.4	8	φ22.4	3/4"
8	343	298.5	269.8	φ200	28.5	8	φ22.4	3/4"
10	406.4	362	323.9	φ250	30.2	12	φ25.4	3/4"
12	482.6	431.8	381	φ300	31.8	12	φ25.4	1"
14	533.4	476.3	412.8	φ336	35.1	12	φ28.5	1"
16	597	539.8	460.9	φ387	36.6	16	φ28.5	1 1/8"
18	635	577.9	533.4	φ438	39.6	16	φ31.8	1 1/8"
20	698.5	635	584.2	φ488	42.9	20	φ31.8	1 1/8"
24	812.8	749.3	692.2	φ600	47.8	20	φ35.1	1 1/4"
26	785.9	744.5	711.2	-	41.2	36	φ22.4	1 1/4"
28	836.7	795.3	762	-	44.5	40	φ22.4	3/4"
30	887.5	846.1	812.8	-	44.5	44	φ22.4	3/4"
32	941.3	900.2	863.6	-	46.0	48	φ22.4	3/4"
34	1004.8	957.4	920.8	-	49.3	40	φ25.4	3/4"
36	1057.2	1009.7	971.6	-	52.3	44	φ25.4	1"
38	1124	1069.9	1022.4	-	53.9	40	φ28.5	1"
40	1174	1120.5	1078.5	-	55.6	44	φ28.5	1"
42	1225.6	1171.5	1130.3	-	58.7	48	φ28.5	1"
44	1276.4	1222.3	1181.1	-	60.5	52	φ28.5	1 1/8"
46	1341.4	1284.2	1235	-	62.0	40	φ31.8	1 1/8"
48	1392.2	1335	1289.1	-	65.0	44	φ31.8	1 1/8"
50	1443	1385.8	1339.9	-	68.3	48	φ31.8	1 1/8"
52	1493.8	1436.6	1390.7	-	69.9	52	φ31.8	1 1/8"

附表Schedule

表4 背压修正系数 Kb Table 4 Backpressure correction factor

Pb/Pd	绝热指数 K Specific heat ratio																			
	0.4	0.5	0.6	0.7	0.8	0.9	1.001	1.1	1.2	1.3	1.4	1.5	1.6	1.7	1.8	1.9	2.0	2.1	2.2	
0.45																				
0.50																				
0.55																				
0.60																				
0.65																				
0.70																				
0.75																				
0.80																				
0.82																				
0.84																				
0.86																				
0.88																				
0.90																				
0.92																				
0.94																				
0.96																				
0.98																				
1.00																				

过压修正系数 Overpressure correction factor

绝对压力 Mpa	绝热指数 K Specific heat ratio	背压修正系数 Kb Backpressure correction factor																				
		200	220	240	260	280	300	320	340	360	380	400	420	440	460	480	500	520	540	560	580	600.0
0.4	1.44	0.99	0.97	0.95	0.93	0.91	0.90	0.88	0.86	0.85	0.84	0.82	0.81	0.80	0.79	0.78	0.76	0.75	0.74	0.73	0.73	0.72
0.7	1.65	0.99	0.98	0.96	0.94	0.92	0.90	0.88	0.87	0.86	0.85	0.84	0.83	0.81	0.80	0.79	0.78	0.76	0.75	0.74	0.73	0.72
1.0	1.80	1.00	0.99	0.98	0.96	0.94	0.92	0.90	0.88	0.87	0.86	0.85	0.84	0.83	0.81	0.80	0.79	0.78	0.77	0.76	0.75	0.74
1.3	1.92	1.00	0.99	0.97	0.94	0.92	0.91	0.89	0.87	0.86	0.84	0.83	0.81	0.80	0.79	0.78	0.77	0.76	0.75	0.74	0.73	0.72
1.6	2.01	1.00	0.99	0.97	0.94	0.93	0.91	0.89	0.88	0.86	0.84	0.83	0.82	0.80	0.79	0.78	0.77	0.76	0.75	0.74	0.73	0.72
1.9	2.10	1.00	0.98	0.96	0.93	0.91	0.89	0.88	0.86	0.85	0.83	0.82	0.80	0.79	0.78	0.77	0.76	0.75	0.74	0.73	0.72	0.71
2.2	2.17	1.00	0.98	0.96	0.94	0.92	0.90	0.88	0.86	0.85	0.83	0.82	0.80	0.79	0.78	0.77	0.76	0.75	0.74	0.73	0.72	0.71
2.5	2.21	1.00	0.99	0.97	0.94	0.92	0.90	0.88	0.87	0.85	0.84	0.82	0.80	0.79	0.78	0.77	0.76	0.75	0.74	0.73	0.72	0.71
3.0	2.34	1.00	0.99	0.96	0.93	0.90	0.89	0.87	0.85	0.84	0.82	0.81	0.79	0.78	0.77	0.76	0.75	0.74	0.73	0.72	0.71	0.70
3.5	2.42	1.00	0.98	0.96	0.93	0.91	0.89	0.87	0.85	0.84	0.82	0.81	0.79	0.78	0.77	0.76	0.75	0.74	0.73	0.72	0.71	0.70
4.0	2.50	1.00	0.99	0.97	0.94	0.92	0.90	0.88	0.86	0.84	0.83	0.81	0.80	0.79	0.78	0.77	0.76	0.75	0.74	0.73	0.72	0.71
4.5	2.58	1.00	0.99	0.97	0.94	0.92	0.90	0.88	0.86	0.84	0.83	0.81	0.80	0.79	0.78	0.77	0.76	0.75	0.74	0.73	0.72	0.71
5.0	2.64	1.00	0.99	0.96	0.93	0.91	0.89	0.87	0.85	0.83	0.82	0.80	0.79	0.78	0.77	0.76	0.75	0.74	0.73	0.72	0.71	0.70
5.5	2.70	1.00	0.99	0.96	0.93	0.91	0.89	0.87	0.85	0.84	0.82	0.81	0.79	0.78	0.77	0.76	0.75	0.74	0.73	0.72	0.71	0.70
6.0	2.76	1.00	0.99	0.97	0.94	0.92	0.90	0.88	0.87	0.85	0.84	0.82	0.81	0.80	0.79	0.78	0.77	0.76	0.75	0.74	0.73	0.72
6.5	2.81	1.00	0.99</																			

美标法兰标准 American Flange Standard ANSIB16.5

美标端法兰
Flange end to ASME B16.5

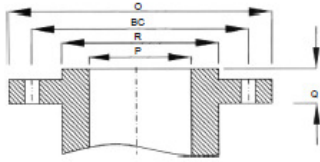

美标压力级900突面法兰
CLASS 900 RF FLANGE TO ASME B16.5

口径 NPS	法兰外径 OD of Flange * O *	螺栓孔直径 Diameter of Bolt Circle * BC *	突面外径 Diameter of RF * R *	阀门通道内径 Valve Port * P * ≥	法兰厚度 Thickness of Flange * Q * ≥	螺栓数量 Number of Bolt	螺栓孔直径 Diameter of Bolt Holes	螺栓外径 Diameter of Bolts
1/2	121	82.5	35	φ13	22.5	4	φ23	
3/4	130	88.9	43	φ17	25.5	4	φ23	
1	149	101.6	51	φ22	29	4	φ26	
1 1/4	159	111.1	64	φ28	29	4	φ26	
1 1/2	178	123.8	73	φ35	32	4	φ29	
2	215.9	165.1	91.9	φ47	38.1	8	φ25.4	7/8"
2 1/2	244.3	190.5	104.0	φ57	41.2	8	φ25.4	1"
3	241.3	190.5	127	φ72	38.1	8	φ25.4	7/8"
4	292.1	235	157.2	φ98	11.5	8	φ31.8	1 1/8"
6	381	317.5	215.9	φ146	56.6	12	φ31.8	1 1/8"
8	469.9	393.7	269.8	φ190	63.5	12	φ38.1	1 3/8"
10	546.1	469.9	323.9	φ238	69.9	16	φ38.1	1 3/8"
12	609.6	533.4	381	φ282	79.2	20	φ38.1	1 3/8"
14	641.4	568.8	412.8	φ311	85.9	20	φ41.2	1 1/2"
16	704.9	616	469.9	φ355	88.9	20	φ44.5	1 5/8"
18	787.4	685.8	533.4	φ400	101.6	20	φ50.8	1 7/8"
20	857.3	749.3	584.2	φ444	108	20	φ53.9	2"
24	1041.4	901.7	692.2	φ533	139.7	20	φ69.6	2 1/2"

美标压力级1500突面法兰
CLASS 1500 RF FLANGE TO ASME B16.5

口径 NPS	法兰外径 OD of Flange * O *	螺栓孔直径 Diameter of Bolt Circle * BC *	突面外径 Diameter of RF * R *	阀门通道内径 Valve Port * P * ≥	法兰厚度 Thickness of Flange * Q * ≥	螺栓数量 Number of Bolt	螺栓孔直径 Diameter of Bolt Holes	螺栓外径 Diameter of Bolts
1/2	121	82.5	35	φ13	22.5	4	φ23	
3/4	130	88.9	43	φ17	25.5	4	φ23	
1	149	101.6	51	φ22	29	4	φ26	
1 1/4	159	111.1	64	φ28	29	4	φ26	
1 1/2	178	123.8	73	φ35	32	4	φ29	
2	215.9	165.1	91.9	φ47	38.1	8	φ25.4	7/8"
2 1/2	244.3	190.5	104.0	φ57	41.2	8	φ25.4	1"
3	241.3	190.5	127	φ72	38.1	8	φ25.4	1 1/8"
4	292.1	235	157.2	φ92	53.9	8	φ35.1	1 1/4"
6	381	317.5	215.9	φ136	62.6	12	φ38.1	1 3/8"
8	469.9	393.7	269.8	φ180	69.9	12	φ38.1	1 3/8"
10	546.1	469.9	323.9	φ222	108	12	φ50.4	1 7/8"
12	609.6	533.4	381	φ263	124	16	φ53.9	2"
14	641.4	568.8	412.8	φ290	134.1	16	φ60.5	2 1/4"
16	704.9	616	469.9	φ330	141.4	16	φ65.5	2 1/2"
18	787.4	685.8	533.4	φ371	162.1	16	φ73.2	3"
20	857.3	749.3	584.2	φ415	177.8	16	φ79.3	3 1/4"
24	1041.4	901.7	692.2	φ468	203.2	16	φ92	3 1/2"

美标法兰标准 American Flange Standard ANSIB16.5

法兰密封面尺寸
Dim. of facing to ASME B16.5

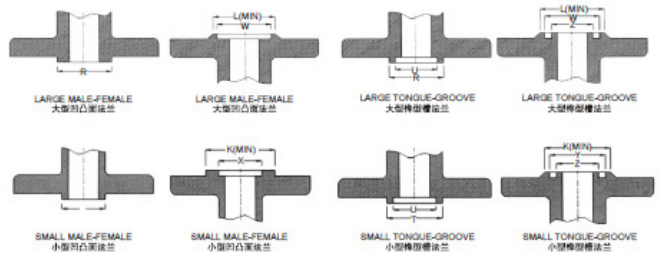

所有压力级之密封面尺寸

DIMENSIONS OF FACINGS (ALL PRESSURE RATING CLASSES)

口径 NPS	外径 OD			大槽式和小槽式内径 ID of large & Small Tongue U	突出部分外径 OD of raised portion ≥		外径 OD			大槽式和小槽式内径 ID of large & small groove Z
	大凸面和大槽式 Large male & Large tongue R	小凸面 Small male S	小槽式 Small tongue T		小凸面和小槽式 Small female & groove K	大凸面和大槽式 Large female & groove L	大凸面和大槽式 Large female & large groove W	小凸面 Small female X	小槽式 Small groove Y	
1/2	34.0	18.3	35.1	25.4	44	46	36.5	19.9	36.5	23.8
3/4	42.9	23.8	42.9	33.3	52	54	44.4	25.4	44.4	31.8
1	50.8	30.2	47.8	38.1	57	62	52.4	31.8	49.2	36.5
1 1/4	63.5	38.1	57.2	47.6	67	75	65.1	39.7	58.7	46
1 1/2	73	44.4	63.5	54	73	84	74.6	46	65.1	52.4
2	91.95	57.15	82.55	73.15	91.95	103.12	93.73	58.67	84.07	71.37
2 1/2	104.65	69.33	95.25	85.25	104.65	115.82	106.43	69.85	96.77	84.07
3	127.00	84.07	117.35	107.95	127.00	138.18	128.52	85.85	119.13	106.43
3 1/2	139.70	96.77	130.05	120.85	139.70	150.88	141.22	98.55	131.83	119.13
4	157.23	109.47	144.53	131.83	157.23	168.18	158.75	111.25	146.05	130.05
5	185.67	135.65	172.97	160.27	185.67	198.85	187.45	138.18	174.75	158.75
6	215.90	162.05	203.20	190.50	215.90	227.08	217.42	163.88	204.72	188.98
8	269.75	212.85	254.00	238.25	269.75	280.93	271.53	214.38	255.62	236.47
10	323.85	266.70	304.80	286.75	323.85	335.03	325.37	268.22	306.32	284.23
12	381.00	317.50	361.95	342.90	381.00	382.18	382.52	319.02	363.47	341.38
14	412.75	349.25	393.70	374.85	412.75	423.93	414.27	360.77	395.22	373.13
16	469.90	400.05	447.55	426.45	469.90	481.08	471.42	401.57	449.33	423.93
18	533.40	450.85	511.05	488.95	533.40	544.58	534.92	452.37	512.83	487.43
20	594.20	501.65	569.80	533.40	594.20	595.38	595.92	503.17	560.32	531.88
24	692.15	603.25	666.75	641.35	692.15	703.33	693.67	604.77	668.27	639.83

美标法兰标准 American Flange Standard ANSIB16.5

美标RTJ端法兰
RTJ Flange end to ASME B16.5

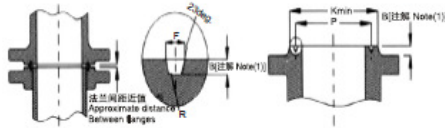

所有压力级的RTJ法兰尺寸
Dimensions of RTJ flange for all Class

口径 NPS	沟槽号 Groove No.	槽尺寸 Groove Dimensions		
		中径 Pitch dia. * P *	深度 Depth * E *	宽度 Width * F *
1/2	R11	34.14	6.54	7.14
3/4	R12	42.88	6.35	8.74
1	R13	50.8	6.35	8.74
1 1/4	R14	63.5	6.35	8.74
1 1/2	R15	73	6.35	8.74
2	R16	91.9	6.35	8.74
2 1/2	R17	104.6	6.35	8.74
3	R18	127	6.35	8.74
4	R19	157.2	6.35	8.74
6	R20	190.5	6.35	8.74
8	R21	235	7.92	11.91
10	R22	282.5	7.92	11.91
12	R23	323.9	7.92	11.91
14	R24	381	7.92	11.91
16	R25	444.5	7.92	11.91
18	R26	511.05	7.92	11.91
20	R27	584.2	7.92	11.91
24	R28	692.2	7.92	11.91

中华人民共和国机械行业标准 Chinese Machinery Industry Standard

JB/T2203-1999

弹簧式安全阀 结构长度 Structural length of spring type safety valve

1、范围 Scope

本标准规定了弹簧式安全阀（以下简称安全阀）的结构长度。本标准适用于公称压力PN1.0-32.0MPa，公称口径DN10-200mm的工业设备和管道用安全阀。

2、结构长度 Structure length

2.1进口为外螺纹、出口为内螺纹的微启式安全阀（图1）结构长度，按表1规定。



图1 Figure 1

表1 Figure 1

公称口径 Nominal Diameter DN	结构长度 Structure length			
	公称压力 Nominal pressure PN Mpa			
	1.0		1.6, 4.0	
	L	L1	L	L1
10	30	45	35	35
15	30	45	35	35
20	35	50	40	40
25	40	60	50	50
32	45	70		
40	50	80		

(1) 法兰突出高度等于槽深E，但其公差不同。Height or raised portion is equal to the depth of groove dimension E, the tolerances are different.
(2) 其它数据详见 ASME B16.5。See ASME B16.5 for the detailed data.

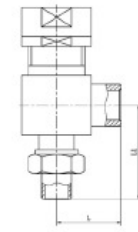
2、2进口为法兰、出口为内螺纹（图2）；进出口为法兰连接（图3）；进出口为螺纹法兰连接（图4）的微启式、双联微启式（图5）和全启式安全阀结构长度，按表2规定。



表1 Figure 1 mm

公称直径 Nominal Diameter DN	型式 Type																
	微启式 Low Lift								全启式 Full Lift								
	公称压力 Nominal pressure PN Mpa								公称压力 Nominal pressure PN Mpa								
	1.0, 1.6, 4.0, 16.0								1.6, 4.0, 16.0, 32.0								
	结构长度 Structure length																
	L	L1	L	L1	L	L1	L	L1	L	L1	L	L1	L	L1	L	L1	
15							42	75	95	95					95	95	
25			100	85													
32			115	100	125	100	130	130	130	130					150	150	
40			120	110	140	110					120	110	135	120	180	180	
50	85	130	135	120	135	120					135	120	160	130	165	155	
80	90	150	170	135	160	130			145	310	205	170	135	175	160	195	185
100									180	355	255	205	160	220	200		
150												250	210				
200												305	260				

微启式安全阀额定排量 Rated Capacity for Low Lift Safety Valve

工作介质:空气 Working medium:air
 温度:T=300° K Temperature:T=300° K
 超过压力:10% Over pressure:10%

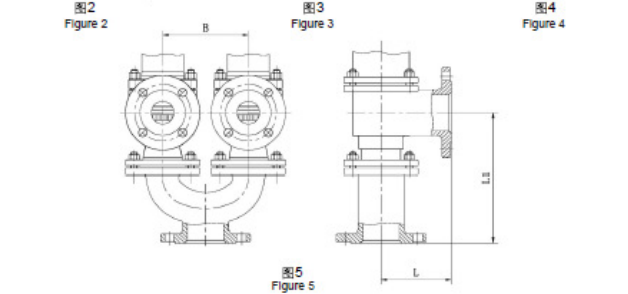
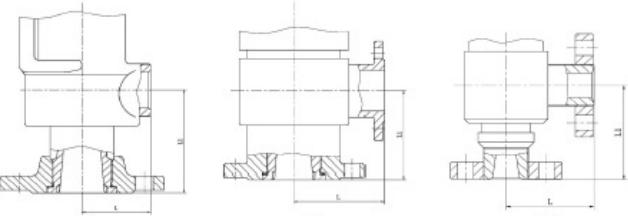
微启式安全阀额定排量 Rated Capacity for Low Lift Safety Valve (Kg/h)

额定压力 Rated pressure Ps(Mpa)	额定排量 Rated discharge Pressure (no) P=0.1(Mpa)	流通直径 Flow diameter											
		12	16	20	25	32	40	50	65	80	100	125	
0.06	0.166	11.0	19.6	30.7	95.8	157	245	383	648	981	1533	2395	
0.08	0.188	12.5	22.2	34.7	108	178	278	434	733	1111	1736	2712	
0.10	0.210	14	24.8	38.8	121	199	310	485	819	1241	1939	3030	
0.13	0.243	16.2	28.7	44.9	140	230	359	561	948	1436	2244	3506	
0.16	0.276	18.3	32.6	51	159	261	408	637	1077	1631	2549	3982	
0.20	0.320	21.3	37.8	59.1	185	303	473	739	1248	1891	2955	4617	
0.25	0.375	24.9	44.3	69.3	216	355	554	866	1463	2216	3463	5410	
0.30	0.430	28.6	50.8	79.4	248	407	635	993	1678	2541	3971	6204	
0.40	0.540	35.9	63.8	99.7	312	511	798	1247	2107	3191	4986	7791	
0.50	0.650	43.2	76.8	120	375	615	960	1500	2536	3841	6002	9378	
0.60	0.760	50.5	89.8	140	439	719	1123	1745	2965	4491	7018	10965	
0.70	0.870	57.8	103	161	502	823	1285	2008	3394	5141	8033	12552	
0.80	0.980	65.2	116	181	566	927	1448	2262	3823	5791	9049	14139	
0.90	1.090	72.5	129	201	629	1031	1610	2516	4252	6441	10065	15726	
1.0	1.200	79.8	142	222	693	1135	1773	2770	4682	7092	11081	17313	
1.1	1.31	87.1	155	242	756	1239	1935	3024	5111	7742	12096	18900	
1.2	1.42	94.4	168	262	819	1343	2096	3278	5540	8392	13112	20487	
1.3	1.53	102	181	283	883	1447	2260	3532	5969	9042	14128	22074	
1.4	1.64	109	194	303	946	1551	2423	3786	6398	9692	15143	23662	
1.5	1.75	116	207	323	1010	1655	2585	4040	6827	10342	16159	25249	
1.6	1.86	124	220	343	1073	1759	2748	4294	7256	10992	17175	26836	
1.8	2.08	138	246	384	1200	1967	3073	4802	8115	12292	19206	30010	
2.0	2.30	153	272	425	1327	2175	3398	5309	8973	13592	21238	33184	
2.2	2.52	168	298	465	1454	2383	3723	5817	9831	14892	23269	36358	
2.5	2.85	189	337	526	1645	2695	4211	6579	11119	16842	26316	41119	
2.8	3.18	211	376	587	1835	3007	4698	7341	12406	18793	29363	45880	
3.2	3.62	241	428	669	2089	3423	5348	8357	14123	21393	33426	52228	
3.6	4.06	270	480	750	2343	3839	5998	9372	15839	23993	37489	58577	
4.0	4.50	299	532	831	2597	4255	6648	10388	17556	26593	41552	64928	
4.5	5.05	336	597	933	2914	4775	7461	11658	19701	29844	46630	72860	
5.0	5.60	372	662	1034	3232	5295	8273	12927	21847	33094	51709	80795	
5.5	6.15	409	727	1136	3549	5815	9086	14197	23993	36344	56788	88731	
6.0	6.70	445	792	1237	3867	6335	9899	15467	26138	39594	61866	96666	
6.4	7.14	475	844	1319	4121	6751	10524	16482	27855	42195	65929	103014	
7.0	7.80	519	922	1440	4501	7375	11524	18006	30430	46095	72023	112536	
8.0	8.90	592	1052	1644	5136	8415	13149	20545	34721	52595	82180	128407	
9.0	10.00	665	1182	1847	5771	9455	14774	23084	39013	59096	92338	144277	
10.0	11.10	738	1312	2050	6406	10495	16399	25624	43304	65597	102495	160148	

全启式安全阀额定排量 Rated Capacity for Full Lift Safety Valve

工作介质:空气 Working medium:air
 温度:T=300° K Temperature:T=300° K
 超过压力:10% Over pressure:10%
 额定排量系数:kdr=0.72 Rated emission factor:kdr= 0.72

全启式安全阀额定排量 Rated Capacity for Full Lift Safety Valve(Kg/h)

额定压力 Rated pressure Ps(Mpa)	额定排量 Rated discharge Pressure (no) P=0.1(Mpa)	流通直径 Flow diameter										
		15	20	25	32	40	50	65	80	100	125	150
0.06	0.166	177	315	493	807	1261	1971	3331	5045	7883	12317	17737
0.08	0.188	201	357	558	914	1428	2232	3772	5714	8928	13950	20087
0.10	0.210	224	399	623	1021	1596	2493	4213	6382	9752	15582	22438
0.13	0.243	260	462	721	1182	1846	2885	4875	7385	11540	18031	25964
0.16	0.276	295	524	819	1342	2097	3277	5538	8368	13107	20479	29490
0.20	0.320	342	608	950	1556	2431	3799	6420	9726	15198	23744	34191
0.25	0.375	401	712	1113	1824	2849	4452	7524	11397	17808	27825	40068
0.30	0.430	459	817	1276	2091	3267	5105	8627	13069	20420	31906	45945
0.40	0.540	577	1026	1603	2626	4103	6411	10834	16412	25243	40068	57658
0.50	0.650	695	1325	1929	3161	4939	7717	13041	19755	30867	48230	69451
0.60	0.760	812	1444	2253	3696	5775	9023	15248	23098	36091	55392	81204
0.70	0.870	930	1635	2582	4231	6610	10329	17455	26441	41314	64554	92958
0.80	0.980	1047	1862	2909	4766	7446	11635	19662	29784	46338	72716	104711
0.90	1.090	1165	2070	3235	5300	8282	12940	21869	33128	51762	80878	116464
1.00	1.200	1282	2279	3562	5835	9118	14246	24076	36471	56985	89040	128217
1.1	1.31	1400	2488	3888	6370	9953	15552	26283	39814	62029	97202	139971
1.2	1.42	1517	2697	4215	6905	10789	16858	28490	43157	67433	103534	151724
1.3	1.53	1635	2905	4541	7440	11625	18164	30697	46500	72656	113526	163477
1.4	1.64	1752	3115	4868	7975	12461	19470	32904	49843	77880	121688	175230
1.5	1.75	1870	3324	5194	8510	13297	20776	35111	53186	83104	129850	186984
1.6	1.86	1987	3533	5520	9045	14132	22092	37319	56530	88328	138012	198737
1.8	2.08	2222	3951	6173	10115	15804	24694	41732	63216	98775	154336	222243
2.0	2.30	2457	4369	6826	11184	17476	27306	46146	69902	109222	170660	245750
2.2	2.52	2693	4787	7479	12254	19147	29917	50560	76588	119670	186984	269256
2.5	2.85	3045	5414	8459	13859	21654	33835	57181	86618	135341	211470	304516
2.8	3.18	3398	6040	9438	15464	24162	37753	63802	96618	150112	235956	339776
3.2	3.62	3868	6876	10744	17603	27505	42977	72630	110020	171906	268603	386789
3.6	4.06	4338	7712	12050	19743	30848	48200	81458	123393	192801	301251	433802
4.0	4.50	4808	8548	13356	21191	34191	53424	90286	136765	213696	333899	480815
4.5	5.05	5396	9693	14988	24557	38370	59953	101321	153481	239814	374709	539581
5.0	5.60	5993	10637	16621	27231	42549	66483	112356	170197	265932	415519	598346
5.5	6.15	6571	11692	18253	29906	46728	73013	123391	186912	292051	458328	657114
6.0	6.70	7159	12727	19896	32581	50907	79542	134426	203628	315159	497139	715880
6.4	7.14	7629	13563	21191	34120	54205	84766	143254	217001	339064	529787	762893
7.0	7.80	8334	14816	23150	37930	59265	92601	156496	237060	370406	578759	833413
8.0	8.90	9509	16906	26415	43279	67823	105661	178566	270491	422642	660379	950945
9.0	10.00	10685	18995	29680	48628	75981	118720	200636	303923	474879	741996	1068478
10.0	11.10	11860	21085	32945	53977	84339	131779	222706	337354	527116	823618	1186011
11.0	12.20	13035	23174	36210	59326	92696	144838	244776	370786	579352	905238	1303543
13.0	14.40	15386	27353	42739	70024	109412	170996	288916	437649	683826	1068478	1538608
16.0	17.70	18912	33621	52533	86071	134485	210134	355126	537943			

微启式安全阀额定排量Rated Capacity for Low Lift Safety Valve

工作介质:饱和水蒸汽 Working medium:saturated water vapor
 超过压力:3% Over pressure:3%

微启式安全阀额定排量Rated Capacity for Low Lift Safety Valve (Kg/h)

额定压力 Rated pressure Pg(Mpa)	额定排量 Rated discharge Pressure (no) Pg=0.1(Mpa)	流通直径 Flow diameter									
		25	32	40	50	65	80	100	125	150	
0.06	0.162	58.4	55.6	149	234	395	598	934	1459	2102	
0.08	0.182	65.8	108	168	263	445	674	1053	1645	2369	
0.10	0.203	73.2	120	187	293	495	750	1172	1831	2637	
0.13	0.234	84.4	138	216	338	570	864	1350	2110	3038	
0.16	0.265	95.5	157	245	382	646	978	1529	2388	3439	
0.20	0.306	110	181	283	442	746	1131	1766	2760	3974	
0.25	0.375	129	221	330	516	872	1321	2064	3225	4643	
0.30	0.409	148	242	378	590	998	1511	2361	3689	5312	
0.40	0.512	185	303	473	739	1249	1892	2956	4618	6650	
0.50	0.615	222	364	568	888	1500	2272	3550	5547	7988	
0.60	0.718	259	424	663	1036	1751	2653	4145	6476	9326	
0.70	0.821	296	485	758	1185	2002	3033	4739	7405	10654	
0.80	0.924	333	546	853	1333	2254	3414	5334	8334	12001	
0.90	1.027	371	607	949	1482	2505	3794	5929	9263	13339	
1.0	1.13	408	668	1044	1631	2756	4175	6523	10192	14677	
1.1	1.23	445	729	1139	1779	3007	4555	7118	11121	16015	
1.2	1.34	482	790	1234	1928	3258	4936	7712	12050	17353	
1.3	1.44	519	851	1329	2077	3510	5316	8307	12979	18690	
1.4	1.54	556	912	1424	2226	3761	5697	8901	13909	20028	
1.5	1.65	594	972	1519	2374	4012	6077	9495	14838	21366	
1.6	1.75	631	1033	1615	2523	4263	6458	10091	15767	22704	
1.8	1.95	705	1155	1805	2820	4766	7219	11280	17625	25380	
2.0	2.16	779	1277	1995	3117	5268	7980	12469	19483	28055	
2.2	2.37	854	1399	2185	3415	5771	8741	13658	21341	30731	
2.5	2.67	965	1581	2471	3960	6524	9883	15442	24128	34744	
2.8	2.98	1077	1764	2756	4306	7278	11024	17226	26915	38758	
3.2	3.40	1225	2007	3137	4901	8283	12547	19604	30631	44109	
3.6	3.81	1374	2251	3517	5496	9288	14069	21982	34347	49460	
4.0	4.22	1523	2495	3898	6090	10292	15591	24361	38064	54812	
4.5	4.73	1708	2799	4373	6833	11548	17494	27334	42709	61501	
5.0	5.25	1894	3103	4849	7577	12805	19396	30307	47354	68190	
5.5	5.77	2080	3408	5325	8320	14061	21299	33279	51999	74879	
6.0	6.28	2266	3712	5800	9063	15317	23202	36252	56644	81568	
6.4	6.69	2414	3956	6181	9658	16321	24724	38631	60360	86919	
7.0	7.31	2637	4321	6752	10550	17829	27007	42198	65935	94946	
8.0	8.34	3009	4930	7703	12036	20341	30812	48144	75225	108324	
9.0	9.37	3381	5539	8654	13522	22853	34618	54094	84516	121702	
10.0	10.40	3752	6418	9606	15009	25365	38423	60036	93806	135081	

微启式安全阀额定排量Rated Capacity for Low Lift Safety Valve

工作介质:水 Working medium:water
 超过压力:20% Over pressure:20%
 出口压力:大气压 Outlet pressure:atmospheric pressure

微启式安全阀额定排量Rated Capacity for Low Lift Safety Valve (Kg/h)

额定压力 Rated pressure Pg(Mpa)	额定排量 Rated discharge Pressure (no) Pg=0.1(Mpa)	流通直径 Flow diameter										
		12	16	20	25	32	40	50	65	80	100	125
0.06	0.072	342	608	950	2969	4865	7061	11876	20071	30403	47505	74227
0.08	0.096	395	702	1097	3428	5617	8777	23176	35107	54854	85710	132121
0.10	0.120	442	785	1227	3833	6280	9813	25912	39251	61329	95827	148121
0.13	0.156	503	895	1399	4370	7160	11188	17481	29544	44753	69926	109259
0.16	0.192	559	993	1552	4848	7944	12412	19394	32776	49649	77576	121212
0.20	0.240	624	1110	1735	5421	8881	13877	21683	36644	55009	86732	135519
0.25	0.300	698	1241	1939	6061	9930	15515	24242	40970	62061	96970	151515
0.30	0.360	765	1360	2125	6639	10877	16996	26556	44880	67984	106225	165977
0.40	0.480	883	1570	2453	7666	12560	19625	30665	51823	78501	122658	191653
0.50	0.600	987	1755	2743	8571	14043	21942	34284	57940	87767	137136	214275
0.60	0.720	1082	1932	3005	9389	15383	24036	37556	63470	96144	150225	234727
0.70	0.840	1168	2077	3245	10141	16616	25962	40565	68556	103847	162262	253534
0.80	0.960	1249	2220	3469	10842	17763	27754	43366	73289	111018	173465	271039
0.90	1.080	1325	2355	3660	11499	18840	29438	45997	77735	117752	183987	287480
1.0	1.20	1396	2482	3879	12121	19859	31030	48485	81940	124121	193940	303031
1.1	1.32	1465	2604	4068	12713	20829	32545	50851	89939	130180	203406	317821
1.2	1.44	1530	2719	4249	13278	21755	33992	53113	89760	135968	212450	331954
1.3	1.56	1592	2830	4423	13820	22643	35380	55281	93425	141520	221125	345808
1.4	1.68	1652	2937	4589	14342	23498	36716	57368	96952	146862	229473	358551
1.5	1.80	1710	3040	4751	14845	24323	38004	59382	100355	152017	237527	371138
1.6	1.92	1766	3140	4906	15332	25120	39251	61329	103646	157003	245316	383307
1.8	2.16	1873	3331	5204	16262	26544	41632	65049	109933	166526	260197	406558
2.0	2.40	1975	3511	5485	17142	28085	43884	68568	115880	175534	274272	428550
2.2	2.64	2071	3682	5753	17979	29456	46025	71915	121536	184102	287659	449467
2.5	3.00	2208	3925	6133	19165	31401	49063	76661	129558	196253	306646	479134
2.8	3.36	2337	4154	6490	20283	33231	51924	81131	137111	207695	324523	507067
3.2	3.84	2498	4441	6939	21683	35526	55509	86732	146578	222035	346930	542078
3.6	4.32	2649	4710	7359	22998	37681	58879	91994	155469	235504	367975	574960
4.0	4.80	2793	4965	7758	24242	39719	62061	96790	163879	248243	387879	606062
4.5	5.40	2962	5266	8228	25713	42128	65825	102852	173820	263301	411408	642825
5.0	6.00	3122	5551	8673	27104	44407	69386	108416	183222	277544	433662	677597
5.5	6.60	3275	5822	9097	28427	46574	72773	113707	192165	291091	454829	710670
6.0	7.20	3420	6081	9501	29691	48645	76009	118763	200710	304034	475053	742271
6.4	7.68	3533	6280	9813	30665	50241	78501	122658	207292	314005	490633	766614
7.0	8.40	3694	6568	10262	32070	52543	82099	128279	216792	326394	513116	801744
8.0	9.60	3950	7021	10971	34284	56171	87767	137136	231760	351068	548544	857100
9.0	10.80	4189	7447	11636	36364	59578	93091	145455	245819	372364	581819	909092
10.0	12	4416	7850	12266	38331	62801	98127	153323	259116	392506	613291	958267

安全阀特性试验曲线Characteristic test curve of safety valve

型号(Type):125CH1A42=420P编号(Valve No.):1438=07/1=1

