

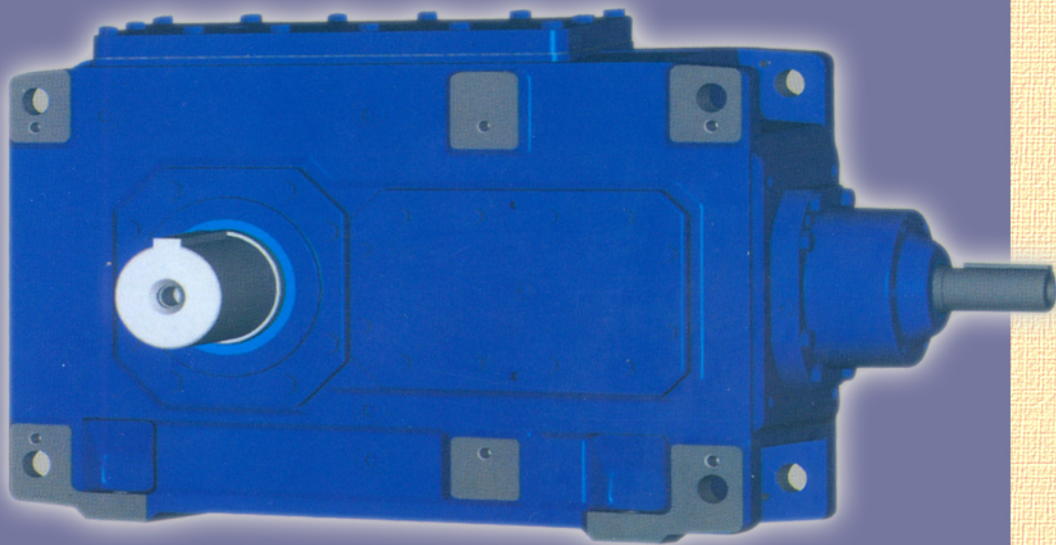

PV 系列通用齿轮箱

PV SERIES GEAR UNITS



山东国茂国泰减速机有限公司

SHANDONG GUOMAOGUOTAI REDUCER CO.,LTD

齿轮箱

基本类型概述

Gear Units

Summary of Basic position

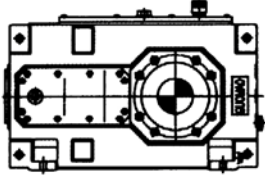
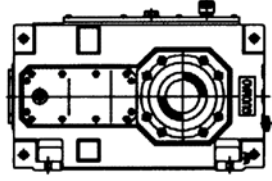
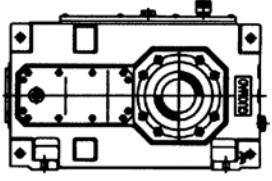
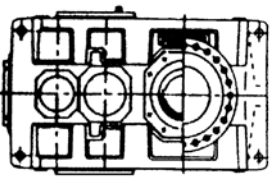
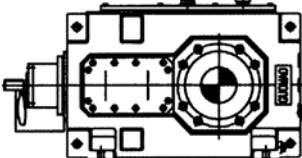
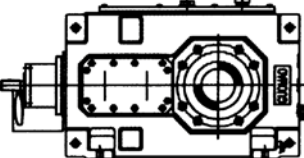
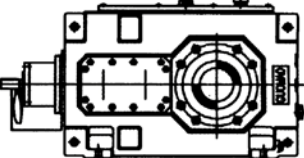
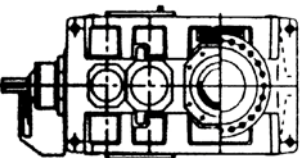
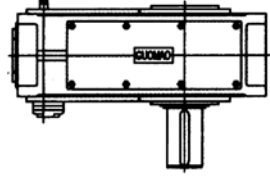
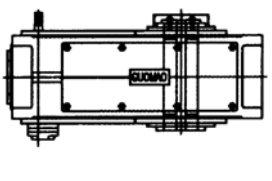
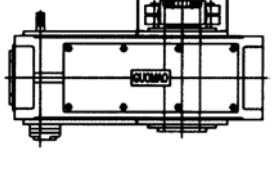
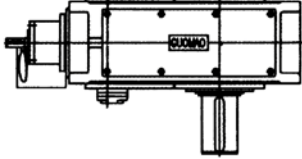
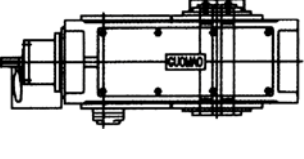
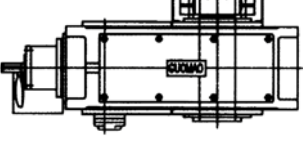
卧式安装		Horizontal mounting position	
平行轴齿轮箱 P1.H、P2.H、P3.H、P4.H 1、2、3、4级, $i_N=1.25-450$		Helical gear units Types P1.H、P2.H、P3.H、P4.H 1、2、3、4 stage, $i_N=1.25-450$	
P.SH 	P.HH 	P.DH 	P.HM P.DM 
垂直轴齿轮箱 V2.H、V3.H、V4.H 2、3、4级, $i_N=5-400$		Bevel-helical gear units Types V2.H、V3.H、V4.H 2、3、4 stage, $i_N=5-400$	
V.SH 	V.HH 	V.DH 	V.HM V.DM 
立式安装		Vertical mounting position	
平行轴齿轮箱 P2.V、P3.V、P4.V 2、3、4级, $i_N=6.3-450$		Helical gear units Types P2.V、P3.V、P4.V 2、3、4 stage, $i_N=6.3-450$	
P.SV 	P.HV 	P.DV 	
垂直轴齿轮箱 V2.V、V3.V、V4.V 2、3、4级, $i_N=5-400$		Bevel-helical gear units Types V2.V、V3.V、V4.V 2、3、4 stage, $i_N=5-400$	
V.SV 	V.HV 	V.DV 	

齿轮箱
基本类型概述

Gear Units
Summary of Basic Types

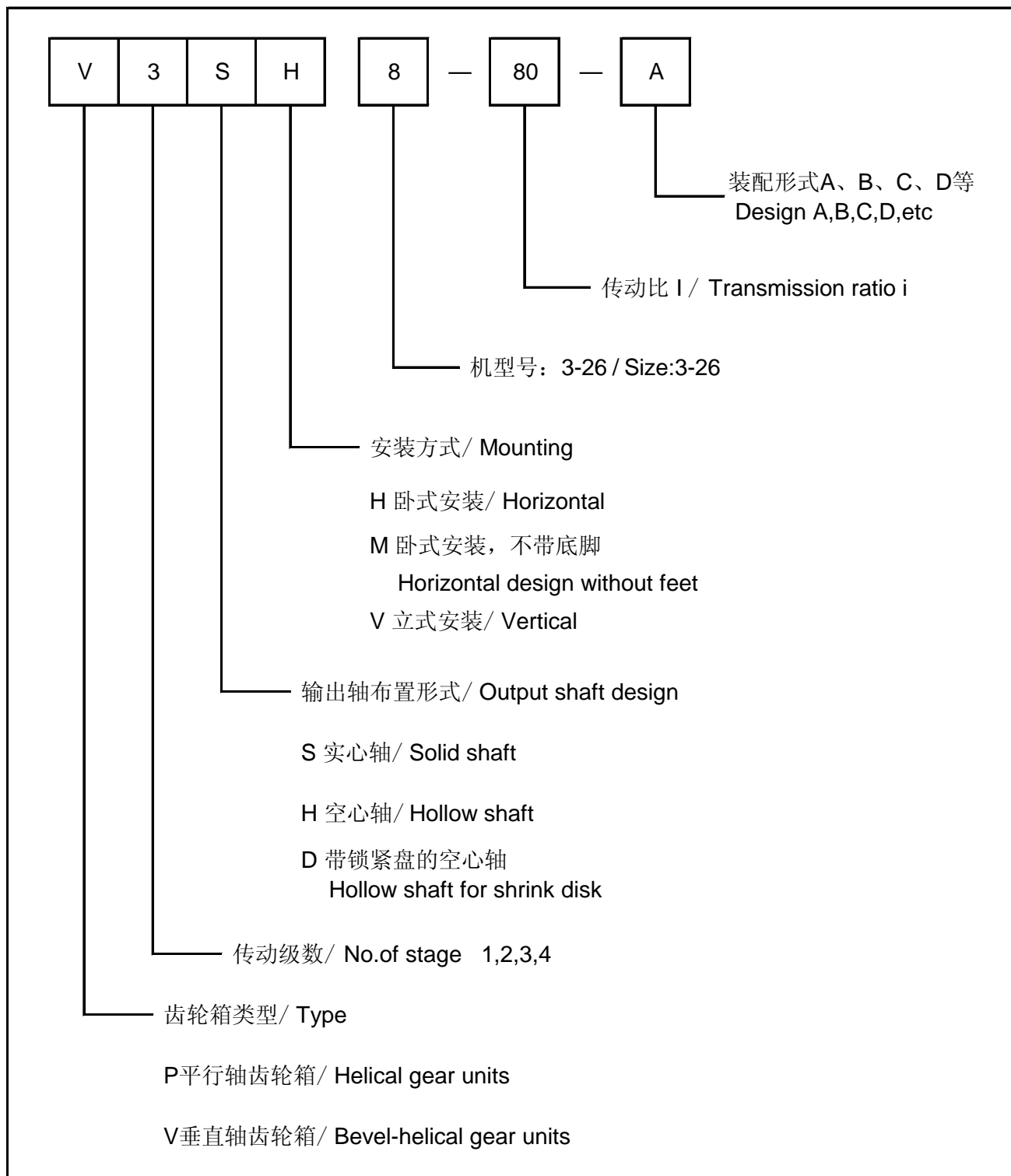

订货时需提供的其他信息:

1. 齿轮箱标准配置为自然冷却、浸油润滑，如需配置冷却装置或强制润滑时应注明。
2. 配置逆止器时应注明，并提供输出轴的旋转方向（面对输出轴）。
3. 输入、输出轴轴伸非标，或安装方式不符合标准时（如壁装或倾斜安装），需提供简图。

齿轮箱

Gear Units

目录

Contents

目录	Contents	页码
产品特性	Characteristic features	4
齿轮箱选型	Selection of gear units	
符号说明	Key to symbols	5
选型指南	Guidelines for the Selection	6
选型示例	Example	7
服务系数	Service Factors	8-9
功率表和热功率表	Tables: Powers and capacities	
P1SH	P1SH	10-12
P2..	P2..	13-17
P3..	P3..	18-22
P4..	P4..	23-25
V2..	V2..	26-28
V3..	V3..	29-34
V4..	V4..	35-37
实际传动比	Actual ratios	38-41
允许附加的径向力	Permissible additional radial forces	42-43
装配形式	Assemblies	44
齿轮箱外形安装尺寸	Gear units install dimensions	
P1SH	P1SH	45
P2.H	P2.H	46-47
P3.H	P3.H	48-49
P4.H	P4.H	50-51
V2.H	V2.H	52-53
V3.H	V3.H	54-55
V4.H	V4.H	56-57
P2.V	P2.V	58-59
P3.V	P3.V	60-61
P4.V	P4.V	62-63
V2.V	V2.V	64-65
V3.V	V3.V	66-67
V4.V	V4.V	68-69
冷却盘管尺寸	Gear units cooling coils	70-71
空心轴安装尺寸	Details on hollow shafts	
带锁紧盘的空心轴	Hollow shafts for shrink disks	72-73
带平键连接的空心轴	Hollow shafts for parallel key connection	74-75

齿轮箱

产品特性

Gear Units

Characteristic Features

设计

P、V系列齿轮箱参考国外同类产品，采用全新设计，主要表现在：

- 1) 高度模块化，零件种类较少而齿轮箱规格较多。
- 2) 传递功率大，运转可靠性高。

安装形式

P、V系列齿轮箱安装方式灵活，可卧式或立式安装，也可按用户要求进行其他形式的安装，敬请垂询。

使用寿命

在正确选型和正常使用、维护的条件下，齿轮箱（除易损件外）的主要零部件寿命一般不低于50000小时。

噪音

齿轮箱的主要零部件都经过精密加工；齿轮磨齿加工采用低噪音的修形技术；采用吸收噪音的箱体结构并通过精心组装和测试，因而齿轮箱噪音较低。

散热性能

P、V系列齿轮箱具有较好的散热性能，主要体现在：

- 1) 齿轮箱具有很高的传动效率
- 2) 设计时增大了箱体的表面积
- 3) 采用大风扇和新型的导流风扇、冷却盘管、油冷却器等多种冷却方式

Design

P、V series gear units are a completely new design. Advantages are:

- 1) Highly standard modular designed, more sizes with a reduced variety combined with increased power capacity.

Mounting position

The gear units can be supplied for either horizontal or vertical installation. Other arrangements are also possible on request.

Long service life

Under the condition of accurately selecting type size and the normal maintenance and use, main components (except those easily-disables parts) can last as long as up to more than 50,000 hours.

Low noise

All key components are finished by precisely machining; grinding the gears; designing noise-absorbing housing; accurate assembly, and finally tested, and therefore, fairly low noise is reached.

Thermal conduction

P、V series gear units a favourable Thermal conduction, because:

- 1) The gear units have a high efficiency.
- 2) Through enlarged housing surface areas.
- 3) Because large fans incorporating a new type of air conduction fan cowl are being used.

齿轮箱

符号说明

Gear Units

Key to Symbols

符号说明		Key to Symbols	
f_1	工作机系数 (表1) 见第8页	f_1	Factor for driven machine (table 1) page 8
f_2	原动机系数 (表2) 见第9页	f_2	Factor for prime mover (table 2) page 9
f_3	峰值扭矩系数 (表3) 见第9页	f_3	Peak torque factor (table 3) page 9
f_4	环境温度系数 (表4) 见第9页	f_4	Thermal factors (table 4) page 9
f_5	环境温度系数 (表5) 见第9页	f_5	Thermal factors (table 5) page 9
f_8	齿轮箱供油系数 对于立式安装齿轮箱见第9页 (表8) 对于卧式安装齿轮箱: $f_8 = 1$	f_8	Oil supply factor for vertical gear units (table 8), page 9 For horizontal gear units: $f_8 = 1$
s_f	可靠性系数 (表9)	s_f	Safety factor (table 9)
i	实际传动比	i	Actual ratio
i_N	公称传送比	i_N	Nominal ratio
i_s	要求传送比	i_s	Required ratio
n_1	输入转速 (rpm)	n_1	Input speed (rpm)
n_2	输出转速 (rpm)	n_2	Output speed (rpm)
P_G	需要的热功率	P_G	Required thermal capacity
P_{GA}	齿轮箱的基础热功率 不带辅助冷却装置	P_{GA}	Thermal capacity for gear units without auxiliary cooling
P_{GB}	齿轮箱的基础热功率 带冷却风扇	P_{GB}	Thermal capacity for gear units with fan cooling
P_{GC}	齿轮箱的基础热功率 带内置冷却盘管	P_{GC}	Thermal capacity for gear units with built-in cooling coil
P_{GD}	齿轮箱的基础热功率 同时带内置冷却盘管和冷却风扇	P_{GD}	Thermal capacity for gear units with built-in cooling coil and fan
P_{2N}	齿轮箱的公称功率 (KW)	P_{2N}	Nominal power rating of gear unit (KW)
P_2	工作机额定功率 (KW)	P_2	Power rating of driven machine (KW)
t	环境温度 (°C)	t	Ambient temperature (°C)
T_A	输入轴最大扭矩 例如峰值工作扭矩 起动扭矩或制动扭矩 (N.m)	T_A	Max. torque occurring on input shaft e.g. peak operating-, starting- or braking torque (N.m)
T_{2N}	公称输出扭矩 (KN.m)	T_{2N}	Nominal output torque (KN.m)

齿轮箱

Gear Units

选型指南

Guidelines for the selection

<p>1. 确定齿轮箱类型和规格 Determination for gear unit type and size</p>	<p>1.1 确定传动比 Find the transmission ratio $i_s = n_1/n_2$</p> <p>1.2 确定齿轮箱额定功率 Determine nominal power rating of the gear unit $P_{2N} \geq P_2 * f_1 * f_2 * S_f$</p> <p>1.3 校核最大扭矩，例如峰值工作扭矩，起动扭矩或制动扭矩： Check for maximum torque, e.g. peak operating-, starting or braking torque $P_{2N} \geq (T_A * n_1 / 9550) f_3$ 根据i_N和P_{2N}在额定功率表中确定的齿轮箱的规格和传动级数 Gear unit sizes and number of reduction stages are given in the rating tables depending on i_N and P_{2N}</p> <p>1.4 校核输出轴允许附加作用力，见第42和43页 Check whether additional forces on the output shaft are permissible; see page 42 and 43</p> <p>1.5 校核实际传动比，见第38至41页 Check whether actual ratio i as per tables on page 38~41 is acceptable</p>					
<p>2. 确定润滑方式 Determination of oil supply</p>	<p style="text-align: center;">安装方式/Mounting position</p> <table border="1" style="width: 100%; border-collapse: collapse;"> <thead> <tr> <th style="width: 50%; text-align: center;">卧式安装/Horizontal</th> <th style="width: 50%; text-align: center;">立式安装/Vertical</th> </tr> </thead> <tbody> <tr> <td style="vertical-align: top;"> <p>可供选择的润滑油供油方式</p> <p>飞溅润滑 浸油润滑 所有需润滑的零部件均浸在润滑油中 强制润滑</p> <p>All parts to be lubricated are lying in the oil or are splash lubricated Forced lubrication on request</p> </td> <td style="vertical-align: top;"> <p>可供选择的润滑油供油方式：</p> <p>浸油润滑 采用法兰泵或电动泵进行强制润滑</p> <p>Possible oil supply variations</p> <p>Dip lubrication Forced lubrication by means of flanged-on pump or motor pump</p> </td> </tr> </tbody> </table>		卧式安装/Horizontal	立式安装/Vertical	<p>可供选择的润滑油供油方式</p> <p>飞溅润滑 浸油润滑 所有需润滑的零部件均浸在润滑油中 强制润滑</p> <p>All parts to be lubricated are lying in the oil or are splash lubricated Forced lubrication on request</p>	<p>可供选择的润滑油供油方式：</p> <p>浸油润滑 采用法兰泵或电动泵进行强制润滑</p> <p>Possible oil supply variations</p> <p>Dip lubrication Forced lubrication by means of flanged-on pump or motor pump</p>
卧式安装/Horizontal	立式安装/Vertical					
<p>可供选择的润滑油供油方式</p> <p>飞溅润滑 浸油润滑 所有需润滑的零部件均浸在润滑油中 强制润滑</p> <p>All parts to be lubricated are lying in the oil or are splash lubricated Forced lubrication on request</p>	<p>可供选择的润滑油供油方式：</p> <p>浸油润滑 采用法兰泵或电动泵进行强制润滑</p> <p>Possible oil supply variations</p> <p>Dip lubrication Forced lubrication by means of flanged-on pump or motor pump</p>					
<p>3. 确定冷却方式 Cooling method</p>	<p>1. 如果满足一下条件，则齿轮箱不需要带辅助冷却装置 Adequate for gear units without auxiliary cooling, if: $P_G = P_{GA} * f_4 * f_8 > P_2$</p> <p>2. 如果满足一下条件，则齿轮箱带冷却风扇可满足要求 Adequate for gear units with fan cooling, if: $P_G = P_{GB} * f_4 * f_8 > P_2$</p> <p>3. 如果满足一下条件，则齿轮箱带冷却盘管可满足要求 Adequate for gear units with cooling coil, if: $P_G = P_{GC} * f_5 * f_8 > P_2$</p> <p>4. 如果满足一下条件，则齿轮箱带冷却盘管和风扇可满足要求 Adequate for gear units with cooling coil and fan, if: $P_G = P_{GD} * f_5 * f_8 > P_2$</p> <p>5. 如果不满足以上条件，则齿轮箱需要带冷却器才能满足要求，敬请垂询 Adequate for gear units with water-oil cooler for higher thermal capacities, on request</p>					

**齿轮箱
选型指南
计算示例**

**Gear Units
Guidelines for the selection
Calculation Example**

<p>已知:</p> <p>原动机 电机功率: P1 = 90kW 电机转速: n1 = 1500rpm 最大起动扭矩: TA = 850N.m</p> <p>工作机 皮带输送机功率: P2 = 82kW 转速: n2 = 30rpm 每天运动时间: 12h/日 每小时起动次数: 7</p> <p>每小时工作周期: ED = 100%/h</p> <p>环境温度: 30℃</p> <p>室内大空间安装: 风速 ≥1.4m/s</p> <p>海波高度: 海平面</p> <p>齿轮箱设计 垂直轴齿轮箱 安装方式: 卧式安装 输出轴d2: 位于齿轮箱右侧, 布置形式C 实心轴</p> <p>输出轴d2的 旋转方向: 逆时针旋转 中等可靠性要求</p>	<p>Known criteria:</p> <p>PRIME MOVER Electric motor: P1 = 90kW Motor speed: n1 = 1500rpm Max. starting torque: TA = 850N.m</p> <p>DRIVEN MACHINE Belt conveyor: P2 = 82kW Speed: n2 = 30rpm Duty: 12h/日 Starts per hour: 7 Operating cycle per hour: ED = 100%/h Ambient temperature: 30℃ Installation in a large hall: wind velocity ≥1.4m/s Altitude: sea level</p> <p>GEAR UNIT DESIGN Bevel-helical gear unit Mounting position: horizontal Output shaft d2: on right handside design C solid shaft</p> <p>Direction of rotation of output shaft d2: ccw</p>
---	--

选型步骤

Selecting steps

<p>1. 确定齿轮箱的规格和类型</p> <p>1.1 确定传动比</p> $i_s = \frac{n_1}{n_2} = \frac{1500}{30} = 50 \quad i_N = 50$ <p>1.2 确定齿轮箱额定功率</p> $P_{2N} \geq P_2 * f_1 * f_2 * S_f = 82 \times 1.3 \times 1 \times 1.4 = 149kW$ <p>从功率表中选择: V3SH11 对应公称功率: P2N = 189 Kw</p> <p>1.3 校核起动扭矩</p> $P_{2N} \geq \frac{T_A \times n_1}{9550} \times f_3 = \frac{850 \times 1500}{9550} \times 0.65 = 133.5kW$ $P_{2N} = 189kW > 133.5kW$ <p>2. 确定润滑方式 齿轮箱采用浸油润滑</p> <p>3. 确定冷却方式 PG=PGA*f4*f8=95.8×0.88×1=84.3kW>P2=82kW 所以齿轮箱不带辅助冷却装置 最终选定齿轮箱: V3SH11-50-C</p>	<p>1. Selection of gear unit and size</p> <p>1.1 Calculation of transmission ratio</p> $i_s = \frac{n_1}{n_2} = \frac{1500}{30} = 50 \quad i_N = 50$ <p>1.2 Determination of the gear unit nominal power rating</p> $P_{2N} \geq P_2 * f_1 * f_2 * S_f = 82 \times 1.3 \times 1 \times 1.4 = 149kW$ <p>Selected from power rating table: type V3SH11 with P2N = 189 Kw</p> <p>1.3 Checking the starting torque</p> $P_{2N} \geq \frac{T_A \times n_1}{9550} \times f_3 = \frac{850 \times 1500}{9550} \times 0.65 = 133.5kW$ $P_{2N} = 189kW > 133.5kW$ <p>2. Determination of oil supply Gear unit with dip lubrication</p> <p>3. Determination of required thermal capacity PG=PGA*f4*f8=95.8×0.88×1=84.3kW>P2=82kW So auxiliary cooling isn't necessary Type: V3SH11-50-C</p>
--	---

**齿轮箱
服务系数**

**Gear Units
Service Factors**

表1 工作机系数f1/Table1 Factor for driven machine f1

工作机 Driven machines		1) 日带载运行 1) Daily load operation			工作机 Driven machines		1) 日带载运行 1) Daily load operation		
		< 0.5	0.5-10	> 10			< 0.5	0.5-10	> 10
污水处理	Waste water treatment				输送机	Conveyors			
浓缩器(中心传动)	Thickeners(central drive)	-	-	1.2	斗式输送机	Bucket conveyors	-	1.4	1.5
压缩机	Filter presses	1.0	1.3	1.5	绞车	Hauling winches	1.4	1.6	1.6
絮凝器	Flocculation apparata	0.8	1.0	1.3	卷扬机	Hoists	-	1.5	1.8
爆气机	Aerators	-	1.8	2	皮带输送机≤150kW	Belt conveyors ≤150kW	1.0	1.2	1.3
搂集设备	Raking equipment	1.0	1.2	1.3	皮带输送机≥150kW	Belt conveyors ≥150kW	1.1	1.3	1.4
纵向、回转组合式	Combined longitudinal and rotary rakes	1.0	1.3	1.5	货用电梯*	Goods lifts	-	1.2	1.5
搂集装置	Pre-thickeners	-	1.1	1.3	客用电梯*	Passenger lifts	-	1.5	1.8
预浓缩器	Screw pumps	-	1.3	1.5	刮板式输送机	Apron conveyors	-	1.2	1.5
螺杆泵	Water turbines	-	-	2.0	自动扶梯	Escalators	1.0	1.2	1.4
水轮机	Pumps				轨道行走机构	Rail traveling gears	-	1.5	-
泵	Centrifugal pumps pumps	1.0	1.2	1.3	变频装置	Frequency converters	-	1.8	2.0
离心泵	Positive-displacement				柱塞式压缩机	Reciprocating compressors	-	1.8	1.9
容积式泵	1 piston	1.3	1.4	1.8	起重机械**	Cranes			
1个活塞	>1 piston	1.2	1.4	1.5	回转机构	Slewing gears	1.0	1.4	1.8
>1个活塞	Dredgers				俯仰机构	Luffing gears	1.0	1.1	1.4
挖泥机	Bucket conveyors	-	1.6	1.6	行走机构	Travelling gears	1.1		2.0
斗式输送机	Dumping devices	-	1.3	1.5	起升机构	Hoisting gears	1.0	1.1	1.4
倾卸装置	Carterpillar traveling gears*	1.2	1.6	1.8	转臂式起重机	Derricking iib cranes	1.0	1.2	1.6
履带式行走机构	Bucket wheel excavators				冷却塔	Cooling tower			
轮式挖掘机	as pick-up	-	1.7	1.7	冷却塔风扇	Cooling tower fans	-	-	2.0
用于料堆捡拾	for primitive material	-	2.2	2.2	风机(轴流和离心式)	Blowers(axial and radial)	-	1.4	1.5
用于原生岩土	Cutter heads	-	2.2	2.2	食品工业	Food industry			
采掘机机头	Traversing gear*	-	1.4	1.8	蔗糖生产	Cane sugar production			
采掘臂回转	Plate bending machines*				甘蔗切碎机*	Cane knives	-	-	1.7
弯板机	Chemical industry				甘蔗碾磨机	cane mills	-	-	1.7
化学工业	Extruders	-	-	1.6	甜菜糖生产	Beet sugar production			
挤出机	Dough mills				甜菜绞碎机	Beet cosettes	-	-	1.2
调浆机	Rubber calenders	-	1.8	1.8	榨取机	macerators	-	-	1.4
橡胶研光机	Cooling drums	-	1.5	1.5	机械制冷机	Extraction plants	-	-	1.4
冷却圆桶	Mixers for				蒸煮机	Mechanical retriboilers			
混合机、用于	Uniform media	1.0	1.3	1.4	甜菜清洗机	Juice boilers			
均匀介质	non-uniform media	1.4	1.6	1.7	甜菜切碎机	Sugar beet washing machines	-	-	1.5
非均匀介质	Agitators for media with				造纸机械	Sugar beet cutters			
搅拌机, 用于	uniform density	1.0	1.3	1.5	各种类型***	Paper machines			
均与介质	non-uniform density	1.2	1.4	1.6	碎浆机驱动装置(敬请垂询)	of all kind	-	1.8	2.0
不均匀介质	non-uniform gas absorption	1.4	1.6	1.8	离心式压缩机	Pulper drives (on request)	-	1.4	1.5
不均匀气体吸收	Toasters	1.0	1.3	1.5	索道缆车	Centrigugal compressors			
烘炉	Centrifuges	1.0	1.2	1.3	运货索道	Materal ropeways	-	1.3	1.4
离心机	Metal working mills				往复式空中索道	To-and-fro system aerial ropeways	-	1.6	1.8
金属加工设备	Plate tilters	1.0	1.0	1.2	拖牵式索道	T-bar lifts	-	1.3	1.4
翻板机	Ingot pushers	1.0	1.2	1.2	循环式索道	Continuous ropeways	-	1.4	1.6
推钢机	Winding machines	-	1.6	1.6	水泥工业	Cement industry			
绕线机	Cooling bed transfer frames	-	1.5	1.5	混凝土搅拌机	Concrete mixers	-	1.5	1.5
冷床横移架	Roller straighteners	-	1.6	1.6	破碎机*	Breakers	-	1.2	1.4
辊式矫直机	Roller table				回转窑	Rotary kilns	-	-	2.0
轨道	continuous	-	1.5	1.5	管式磨机	Tube mills	-	-	2.0
连续式	intermittent	-	2.0	2.0	选粉机	Separators	-	1.6	1.6
间歇式	Reversing tube mills	-	1.8	1.8	辊压机	Roll crushers	-	-	2.0
可逆式轧管机	Shears								
剪切机	continuous	-	1.5	1.5					
连续式	crank type	1.0	2.0	2.0					
曲柄式	continuous casting drivers	-	1.8	1.8					
连铸机驱动装置	Rolls blooming mills								
轧机	Reversing	-	2.5	2.5					
可逆式开坯机	Reversing	-	2.5	2.5					
可逆式板坯轧机	slabbing mills								
可逆式线材轧机	Reversing wire mills	-	1.8	1.8					
可逆式薄板轧机	Reversing sheet mills	-	2.0	2.0					
可逆式中厚板轧机	Reversing plate mills	-	1.8	1.8					
辊缝调节驱动装置	Roll adjustment drives	0.9	1.0	-					

齿轮箱 服务系数

Gear Units Service Factors

原动机类型	f_2
电机, 液压马达, 汽轮机	1.0
4-6缸活塞发动机 周期变化1:100至1:200	1.25
1-3缸, 活塞发动机 周期变化最高达1:100	1.5

Prime mover type	f_2
Electric motors, hydraulic motors, turbines	1.0
Piston engines 4-6 cylinders, cyclic variation 1:100 to 1:200	1.25
Piston engines 1-3 cylinders, cyclic variation up to 1:100	1.5

	每小时峰值载荷次数			
	1-5	6-30	31-100	>100
单向荷载	0.5	0.65	0.7	0.85
交变荷载	0.7	0.95	1.10	1.25

	Load peaks per hour			
	1-5	6-30	31-100	>100
Steady direction of load	0.5	0.7	0.7	0.85
Alternating direction of	0.7	1	1.10	1.25

环境温度 / Ambient	10°C	15°C	20°C	25°C	30°C	35°C	40°C	45°C	50°C
f_4	1.11	1.06	1.00	0.94	0.88	0.82	0.75	0.69	0.63

环境温度 / Ambient	10°C	15°C	20°C	25°C	30°C	35°C	40°C	45°C	50°C
f_5	1.05	1.03	1.00	0.97	0.93	0.90	0.87	0.84	0.81

齿轮箱类型 Gear unit type	供油方式 Oil supply	规格 / Sizes 4 - 12				规格 / Sizes 13 - 18			
		不带辅助冷却装置 without Auxiliary cooling	带冷却风扇 with Fan	带冷却盘管 with Cooling coil	带冷却风扇和冷却盘管 with Fan and cooling coil	不带辅助冷却装置 without Auxiliary	带冷却风扇 with Fan	带冷却盘管 with Cooling coil	带冷却风扇和冷却盘管 with Fan and cooling coil
P2.V, P3.V P4.V	浸油润滑 Dip lubrication	0.95		0.95	+	+	+	+	+
	强制润滑 Forced lubrication	1.15		1.05	+	1.15	+	1.05	+
V2.V, V3.V V4.V	浸油润滑 Dip lubrication	0.95	0.95	0.95	0.95	+	+	+	+
	强制润滑 Forced lubrication	1.15	1.10	1.10	1.10	1.15	1.10	1.10	1.10

低可靠性要求	1.2-1.3
中等可靠性要求	1.3-1.5
高可靠性要求	1.5-1.7

low	1.2-1.3
normal	1.3-1.5
high	1.5-1.7

+) 敬请垂询

+) On request

齿轮箱

公称功率和输出扭矩

类型 P1

规格 3-19

Gear Units

Nominal Power Rating and Output Torque

Type P1

Sizes 3-19

公称功率P _{2N} (kW)和公称输出扭矩T _{2N} (kN.m) / Nominal power ratings P _{2N} (kW) and output torque T _{2N} (kN.m)																				
iN	n1	n2	齿轮箱规格/Gear unit sizes (3-19)																	
			3		5		7		9		11		13		15		17		19	
			P _{2N}	T _{2N}	P _{2N}	T _{2N}	P _{2N}	T _{2N}	P _{2N}	T _{2N}	P _{2N}	T _{2N}	P _{2N}	T _{2N}	P _{2N}	T _{2N}	P _{2N}	T _{2N}	P _{2N}	T _{2N}
1.3	1500	1200	382		1055		2004		3258											
	1000	800	254	3.0	704	8.4	1337	16	2172	25.9										
	750	600	191		528		1002		1629											
1.4	1500	1071	364		965		1872		3014											
	1000	714	243	3.2	644	8.6	1247	16.7	2009	26.9										
	750	536	182		482		936		1507											
1.6	1500	938	340		886		1680		2794		4744									
	1000	625	226	3.4	590	9.0	1119	17.1	1862	28.4	3161	48.3	4322	66.0						
	750	469	170		443		840		1397		2372		2881							
1.8	1500	833	247		805		1593		2564		4359									
	1000	556	165	2.8	538	9.2	1064	18.3	1712	29.4	2910	50.0	4044	69.5						
	750	417	123		403		796		1282		2179		2696							
2	1500	750	215		723		1369		2208		3779									
	1000	500	143	2.7	482	9.2	912	17.4	1472	28.1	2519	48.1	3740	71.4						
	750	375	107		362		685		1104		1889		2493							
2.2	1500	670	192		660		1223		1973		3478									
	1000	446	127	2.7	439	9.4	814	17.4	1313	28.1	2316	49.5	3441	73.6						
	750	335	96		330		612		986		1739		2294							
2.5	1500	600	178		591		1096		1767		3115		4740							
	1000	400	119	2.8	394	9.4	730	17.4	1178	28.1	2077	49.6	3161	75.5	4655	111.1				
	750	300	89		295		548		883		1558		2370		3103					
2.8	1500	536	170		527		940		1495		2782		4235							
	1000	357	113	3.0	351	9.4	626	16.7	996	26.6	1853	49.6	2820	75.4	4261	113.9				
	750	268	85		264		470		748		1391		2117		2841					
3.2	1500	476	151		468		850		1372		2349		3570							
	1000	317	100	3.0	312	9.4	565	17.0	913	27.5	1564	47.1	2377	71.5	3910	117.6				
	750	238	75		234		425		686		1175		1785		2607					
3.6	1500	423	138		412		772		1241		2179		3229							
	1000	282	92	3.1	274	9.3	515	17.4	827	28.0	1452	49.2	2152	73.0	3534	119.8				
	750	211	69		206		386		620		1089		1615		2356					
4	1500	375	119		357		663		1070		1887		2823							
	1000	250	79	3.0	238	9.1	442	16.9	713	27.3	1258	48.0	1882	71.9	3233	123.5	4302	164.3		
	750	188	59		179		332		535		943		1412		2155		2868			
4.5	1500	333	83		255		523		814		1523		2040		3610					
	1000	222	55	2.4	169	7.3	349	15.0	542	23.3	1016	43.6	1359	58.4	2406	103.4	3223	138.5		
	750	167	41		127		261		407		761		1020		1805		2149			
5	1500	300	71		215		411		701		1154		1739		2835		3700			
	1000	200	48	2.3	143	6.8	275	13.1	467	22.3	770	36.7	1159	55.3	1890	90.2	2466	117.8	3461	165.3
	750	150	36		107		206		351		577		870		1417		1850		2307	
5.6	1500	268	61		183		349		536		973		1476		2409		3145		3999	
	1000	179	41	2.2	123	6.6	233	12.4	357	19.1	650	34.8	986	52.7	1609	86.1	2100	112.3	2670	142.8
	750	134	30		92		174		268		486		738		1205		1573		1999	

采取强制润滑

Forced lubrication required



齿轮箱

热功率

类型 P1

规格3-11

Gear Units

Thermal Capacities

Type P1

Sizes 3-11

热功率P _G (KW)/Thermal capacities P _G (KW)																
i _N	n1	齿轮箱规格/gear unit sizes 3-11														
		3			5			7			9			11		
		750	1000	1500	750	1000	1500	750	1000	1500	750	1000	1500	750	1000	1500
1.25	P _{GA}	68	63.2	*	*	*	*	*	*	*	*	*	*			
	P _{GB}	157	187	210	338	402	372	427	517	408	443	536	*			
	P _{GC}	234	271	307	553	639	686	798	911	946	1128	1288	1276			
	P _{GD}	312	377	472	773	934	1117	1080	1322	1537	1456	1783	1991			
1.4	P _{GA}	70	65.4	*	*	*	*	*	*	*	*	*	*			
	P _{GB}	156	186	212	344	409	392	441	534	447	477	578	375			
	P _{GC}	228	264	299	544	629	680	781	892	937	1119	1277	1285			
	P _{GD}	303	366	459	758	916	1104	1060	1298	1523	1437	1760	1992			
1.6	P _{GA}	73	68.6	*	*	*	*	*	*	*	*	*	*	*	*	*
	P _{GB}	154	183	213	346	412	420	446	540	500	520	630	495	602	729	*
	P _{GC}	215	248	284	515	595	655	730	833	894	1077	1230	1276	1802	2057	1944
	P _{GD}	287	347	438	720	870	1063	991	1214	1452	1393	1706	1982	2318	2838	3039
1.8	P _{GA}	85	79.9	*	*	*	*	*	*	*	*	*	*	*	*	*
	P _{GB}	172	205	241	344	410	435	463	561	554	541	655	575	678	821	*
	P _{GC}	233	269	309	485	561	625	717	819	894	1040	1187	1259	1774	2025	1990
	P _{GD}	311	376	478	684	827	1019	977	1196	1450	1348	1650	1953	2288	2802	3106
2	P _{GA}	84	78.5	*	111	104	*	*	*	*	*	*	*	*	*	*
	P _{GB}	165	197	234	333	397	427	453	549	553	538	651	590	704	852	509
	P _{GC}	221	256	295	459	531	593	682	778	852	990	1130	1207	1713	1955	1947
	P _{GD}	296	358	455	645	779	964	927	1135	1382	1285	1573	1873	2205	2700	3026
2.24	P _{GA}	74	78	*	104	109	*	*	*	*	*	*	*	*	*	*
	P _{GB}	159	189	227	321	382	422	430	520	544	533	645	620	733	887	631
	P _{GC}	208	241	278	429	496	558	617	704	779	931	1063	1151	1633	1864	1902
	P _{GD}	280	338	431	607	733	913	840	1029	1264	1213	1485	1790	2114	2588	2964
2.5	P _{GA}	69	72.8	*	103	108	*	*	*	*	*	*	*	*	*	*
	P _{GB}	147	175	211	304	362	405	408	494	525	513	621	614	730	884	676
	P _{GC}	187	216	251	397	459	518	569	649	723	864	986	1075	1536	1753	1810
	P _{GD}	252	304	388	562	679	848	776	950	1172	1128	1381	1674	1990	2437	2819
2.8	P _{GA}	66	69.6	50	100	105	*	138	133	*	*	*	*	*	*	*
	P _{GB}	138	164	199	286	340	384	422	511	553	536	649	658	714	865	705
	P _{GC}	172	199	231	362	419	475	574	655	733	871	994	1091	1424	1625	1698
	P _{GD}	233	281	359	513	620	777	783	959	1189	1135	1390	1695	1850	2265	2647
3.15	P _{GA}	70	73	63.8	121	127	*	196	189	*	226	217	*	*	*	*
	P _{GB}	135	161	200	292	348	415	496	601	702	604	731	828	842	1019	1055
	P _{GC}	167	193	226	360	416	481	674	769	881	956	1091	1237	1473	1682	1858
	P _{GD}	223	270	348	506	612	779	931	1140	1442	1264	1548	1941	1918	2349	2879
3.55	P _{GA}	64	67.6	59.8	121	127	*	185	178	*	217	209	*	*	*	*
	P _{GB}	123	147	183	286	340	407	457	553	649	563	682	778	784	949	998
	P _{GC}	151	174	204	344	398	460	604	689	791	865	988	1124	1331	1519	1685
	P _{GD}	202	244	314	484	585	746	839	1027	1301	1149	1407	1768	1738	2128	2617
4	P _{GA}	59	61.9	56.2	112	118	85.1	174	167	*	196	189	*	244	235	*
	P _{GB}	113	134	166	260	309	374	411	498	591	483	585	677	736	891	964
	P _{GC}	134	155	181	305	353	410	529	604	696	719	820	937	1202	1372	1534
	P _{GD}	180	217	280	431	521	665	737	902	1147	960	1175	1483	1574	1927	2387
4.5	P _{GA}	66	69.7	66.4	123	129	106	190	183	135	247	238	*	278	267	*
	P _{GB}	121	144	180	265	316	389	416	504	611	551	667	795	720	872	994
	P _{GC}	143	165	194	306	354	413	525	599	696	795	908	1049	1148	1310	1489
	P _{GD}	190	230	298	431	521	669	726	889	1137	1057	1294	1646	1515	1855	2330
5	P _{GA}	61	63.9	62.5	119	125	111	191	184	151	237	228	169	301	290	*
	P _{GB}	110	131	165	253	301	373	403	488	599	502	608	738	718	869	1020
	P _{GC}	127	147	173	288	333	390	494	564	659	702	801	930	1089	1243	1427
	P _{GD}	170	205	266	406	490	631	687	841	1080	935	1145	1464	1446	1770	2242
5.6	P _{GA}	55	57.2	56	106	111	98.8	173	166	136	229	220	163	288	277	*
	P _{GB}	97	116	146	223	266	330	359	435	535	480	581	704	680	823	967
	P _{GC}	111	128	151	249	288	337	433	494	577	653	745	866	1020	1164	1337
	P _{GD}	148	179	232	352	425	548	604	739	949	875	1071	1370	1358	1663	2106

*敬请垂询

P_{GA}(KW) 齿轮箱不带辅助冷却措施

P_{GB}(KW) 齿轮箱带冷却风扇

P_{GC}(KW) 齿轮箱带内置冷却盘管

P_{GD}(KW) 齿轮箱带冷却风扇和内置冷却盘管

*On request

P_{GA}(KW) Gear units without auxiliary cooling

P_{GB}(KW) Gear units with fan

P_{GC}(KW) Gear units with built-in cooling coil

P_{GD}(KW) Gear units with fan and built-in coil



齿轮箱
热功率
类型 P1
规格 13-19

Gear Units
Thermal Capacities
Type P1
Sizes 13-19

热功率P _G (KW)/Thermal capacities P _G (KW)													
i _N	n1	齿轮箱规格/gear unit sizes 13-19											
		13			15			17			19		
		750	1000	1500	750	1000	1500	750	1000	1500	750	1000	1500
1.25	P _{GA}												
	P _{GB}												
	P _{GC}												
	P _{GD}												
1.4	P _{GA}												
	P _{GB}												
	P _{GC}												
	P _{GD}												
1.6	P _{GA}	*	*	*									
	P _{GB}	431	510	*									
	P _{GC}	2154	2459	2060									
	P _{GD}	2733	3313	3187									
1.8	P _{GA}	*	*	*									
	P _{GB}	570	674	*									
	P _{GC}	2117	2417	2161									
	P _{GD}	2693	3264	3328									
2	P _{GA}	*	*	*	*	*	*	*	*	*	*	*	*
	P _{GB}	640	757	*	*	*	*	*	*	*	*	*	*
	P _{GC}	2074	2368	2161	1870	2073	1626	*	*	*	*	*	*
	P _{GD}	2632	3190	3313	2571	3116	2826	*	*	*	*	*	*
2.24	P _{GA}	*	*	*	*	*	*	*	*	*	*	*	*
	P _{GB}	720	851	*	442	523	*	*	*	*	*	*	*
	P _{GC}	2006	2290	2172	1847	2048	1719	*	*	*	*	*	*
	P _{GD}	2561	3104	3336	2535	3073	2963	*	*	*	*	*	*
2.5	P _{GA}	*	*	*	*	*	*	*	*	*	*	*	*
	P _{GB}	751	888	*	525	621	*	*	*	*	*	*	*
	P _{GC}	1904	2174	2102	1818	2016	1746	*	*	*	*	*	*
	P _{GD}	2438	2955	3228	2472	2996	2972	*	*	*	*	*	*
2.8	P _{GA}	*	*	*	*	*	*	*	*	*	*	*	*
	P _{GB}	763	902	*	598	707	*	423	500	*	*	*	*
	P _{GC}	1782	2034	2002	1765	1957	1748	2009	2203	1836	*	*	*
	P _{GD}	2285	2770	3075	2386	2892	2947	2659	3223	3087	*	*	*
3.15	P _{GA}	*	*	*	*	*	*	*	*	*	*	*	*
	P _{GB}	954	1128	1033	970	1146	816	880	1040	*	*	*	*
	P _{GC}	1818	2075	2221	1965	2179	2223	2295	2517	2487	*	*	*
	P _{GD}	2346	2844	3394	2619	3174	3634	2990	3624	4035	*	*	*
3.55	P _{GA}	*	*	*	*	*	*	*	*	*	*	*	*
	P _{GB}	912	1078	1014	964	1140	860	927	1096	678	*	*	*
	P _{GC}	1661	1896	2042	1828	2027	2087	2176	2387	2387	*	*	*
	P _{GD}	2147	2603	3123	2427	2942	3397	2815	3412	3829	*	*	*
4	P _{GA}	*	*	*	*	*	*	*	*	*	*	*	*
	P _{GB}	866	1024	1012	951	1124	938	958	1132	821	873	1032	623
	P _{GC}	1502	1715	1870	1670	1851	1943	2017	2212	2263	*	*	*
	P _{GD}	1950	2364	2866	2221	2692	3159	2605	3158	3625	*	*	*
4.5	P _{GA}	345	304	*	*	*	*	*	*	*	*	*	*
	P _{GB}	937	1107	1193	1090	1289	1261	1106	1307	1192	1078	1274	1069
	P _{GC}	1562	1783	1992	1721	1908	2075	2031	2227	2382	*	*	*
	P _{GD}	2041	2474	3062	2277	2760	3339	2615	3170	3779	*	*	*
5	P _{GA}	386	340	*	*	*	*	*	*	*	*	*	*
	P _{GB}	920	1087	1227	1114	1317	1395	1304	1541	1560	1341	1585	1526
	P _{GC}	1477	1686	1911	1642	1820	2022	2210	2424	2660	*	*	*
	P _{GD}	1937	2348	2942	2180	2642	3255	2844	3447	4202	*	*	*
5.6	P _{GA}	353	311	*	*	*	*	*	*	*	*	*	*
	P _{GB}	827	978	1104	1101	1195	1266	1198	1416	1433	1409	1665	1604
	P _{GC}	1295	1478	1675	1450	1608	1787	1967	2157	2367	*	*	*
	P _{GD}	1704	2065	2586	1629	2338	2880	2532	3069	3741	*	*	*

*敬请垂询

*On request

P_{GA}(KW) 齿轮箱不带辅助冷却措施

P_{GA}(KW) Gear units without auxiliary cooling

P_{GB}(KW) 齿轮箱带冷却风扇

P_{GB}(KW) Gear units with fan

P_{GC}(KW) 齿轮箱带内置冷却盘管

P_{GC}(KW) Gear units with built-in cooling coil

P_{GD}(KW) 齿轮箱带冷却风扇和内置冷却盘管

P_{GD}(KW) Gear units with fan and built-in coil



齿轮箱
公称功率和输出扭矩
类型 P2
规格4-15

Gear Units
Nominal Power Rating and output torque
Type P2
Sizes 4-15

公称功率 P_{2N} (KW) 和公称输出扭矩 T_{2N} (kn.m) / nominal power ratings P_{2N} (kw) and output torque T_{2N} (kn.m)

i_N	n1	n2	齿轮箱规格/gear unit sizes 4-15																							
			4		5		6		7		8		9		10		11		12		13		14		15	
			P_{2N}	T_{2N}	P_{2N}	T_{2N}	P_{2N}	T_{2N}	P_{2N}	T_{2N}	P_{2N}	T_{2N}	P_{2N}	T_{2N}	P_{2N}	T_{2N}	P_{2N}	T_{2N}	P_{2N}	T_{2N}	P_{2N}	T_{2N}	P_{2N}	T_{2N}	P_{2N}	T_{2N}
6	1500	238	165		279				530				881				1551				2250				3741	
	1000	159	109	6.6	187	11.2			354	21.3			589	35.4			1036	62.4			1503	90.4			2499	150
	750	119	82		140				265				442				777				1127				1874	
7	1500	211	150		259				470				781				1376				1995				3317	
	1000	141	100	6.8	173	11.7			314	21.3			522	35.4			919	62.3			1332	90.3			2217	150
	750	106	75		130				235				391				689				999				1662	
8	1500	188	138		231		278		419		528		696		872		1225		1525		1777		2211		2956	
	1000	125	91	7.0	153	11.7	185	14.1	278	21.3	352	26.9	462	35.4	580	44.3	815	62.3	1013	77.4	1181	90.2	1470	112	1965	150
	750	94	69		115		139		209		264		347		435		611		760		886		1103		1473	
9	1500	167	123		205		264		372		469		618		774		1088		1355		1578		1965		2625	
	1000	111	81	6.9	137	11.7	175	15.1	247	21.2	312	26.8	411	35.3	515	44.2	723	62.2	900	77.3	1049	90.2	1305	112	1745	150
	750	83	61		102		132		185		234		308		386		543		675		787		979		1309	
10	1500	150	96		161		237		312		422		518		695		912		1217		1323		1764		2201	
	1000	100	64	6.1	107	10.2	158	15.0	208	19.8	281	26.9	345	32.9	463	44.2	608	58	811	77.4	882	84.2	1176	112	1467	140
	750	75	48		80		118		156		211		259		347		456		608		662		882		1100	
11	1500	134	86		145		212		278		377		463		622		815		1087		1182		1576		1966	
	1000	89	57	6.1	96	10.3	141	15.0	185	19.8	250	26.7	308	32.9	413	44.1	541	57.9	721	77.2	785	84	1047	112	1305	140
	750	67	43		72		106		139		187		231		309		406		541		589		785		979	
13	1500	120	82		137		166		248		315		415		519		730		908		1058		1317		1760	
	1000	80	55	6.6	91	10.9	111	13.2	166	19.8	210	25	276	33	346	41.3	486	58	606	72.3	706	84.2	878	105	1173	140
	750	60	41		68		83		124		157		207		259		365		454		529		659		880	
14	1500	107	74		123		148		222		280		369		463		651		809		944		1174		1570	
	1000	71	48	6.4	81	10.9	98	13.1	147	19.7	186	24.9	245	32.8	307	41	431	57.7	537	71.8	626	83.7	779	104	1042	139
	750	54	36		61		74		110		140		184		230		323		403		470		584		781	
16	1500	94	64		108		138		195		245		324		407		571		711		829		1032		1379	
	1000	63	43	6.6	72	10.9	92	14.1	130	19.9	165	25.2	218	33.2	272	41.6	383	58.5	476	72.8	556	84.9	691	106	924	141
	750	47	32		54		69		98		123		163		204		287		357		417		518		693	
18	1500	83	53		89		123		162		218		286		359		505		628		732		910		1217	
	1000	56	35	6.1	60	10.3	82	14.2	109	18.7	147	25.3	193	33.2	242	41.6	340	58.5	423	72.8	494	84.9	614	106	821	141
	750	42	26		45		62		82		110		145		182		255		318		370		461		616	
20	1500	75	48		83		111		142		197		251		324		442		567		641		823		1067	
	1000	50	32	6.2	55	10.5	74	14.0	94	18.0	131	25.1	167	31.9	216	41.2	295	56.2	378	72.3	428	81.7	549	105	711	136
	750	38	24		41		55		71		98		125		162		221		284		321		412		533	
22	1500	67	42		72		92		131		165		220		290		389		507				735			
	1000	45	28	5.9	48	10.4	62	13.2	86	18.9	111	23.7	147	31.5	194	41.5	260	55.7	340	72.7			494	106		
	750	33	21		36		46		66		83		110		146		195		255				370			
25	1500	60					85				143				252				440				638			
	1000	40					56	13.4			95	22.7			167	39.9			294	70.1			426	102		
	750	30					42				71				125				220				319			
28	1500	54					74				134				223				389							
	1000	36					56	14.9			89	23.9			148	39.6			259	69.4						
	750	27					42				67				111				195							

采取强制润滑

Forced lubrication required



齿轮箱
公称功率和输出扭矩
类型 P2
规格 16-26

Gear Units
Nominal Power Rating and output torque
Type P2
Sizes 16-26

公称功率 P_{2N} (KW) 和公称输出扭矩 T_{2N} (kn.m) / nominal power ratings P_{2N} (kw) and output torque T_{2N} (kn.m)																								
i_N	n_1	n_2	齿轮箱规格/gear unit sizes 16-26																					
			16		17		18		19		20		21		22		23		24		25		26	
			P_{2N}	T_{2N}	P_{2N}	T_{2N}	P_{2N}	T_{2N}	P_{2N}	T_{2N}	P_{2N}	T_{2N}	P_{2N}	T_{2N}	P_{2N}	T_{2N}	P_{2N}	T_{2N}	P_{2N}	T_{2N}	P_{2N}	T_{2N}	P_{2N}	T_{2N}
6.3	1500	238			5102																			
	1000	159			3408	205			5104	307														
	750	119			2556				3828															
7.1	1500	211	3712		4523																			
	1000	141	2480	168	3023	205	3565	242	4527	307	5193	352												
	750	106	1860		2267		2674		3395		3895													
8	1500	188	3306		4030		4753																	
	1000	125	2199	168	2680	205	3161	241	4012	307	4603	352												
	750	94	1649		2010		2370		3009		3452													
9	1500	167	2937		3579		4222																	
	1000	111	1952	168	2379	205	2807	241	3563	306	4088	351	4670	401										
	750	83	1464		1784		2105		2672		3066		3502											
10	1500	150	2639		3001		3793		4494															
	1000	100	1759	168	2000	191	2528	241	2996	286	3682	352	4207	402	4699	449								
	750	75	1319		1500		1896		2247		2762		3155		3524									
11.2	1500	134	2200		2681		3162		4015		4606													
	1000	89	1461	156	1781	190	2100	225	2667	285	3059	327	3744	400	4183	447								
	750	67	1096		1335		1575		2000		2294		2808		3137									
12.5	1500	120	1970		2401		2832		3596		4125													
	1000	80	1313	157	1600	191	1887	225	2397	286	2750	328	3365	402	3759	449	4433	529						
	750	60	985		1200		1416		1798		2062		2524		2819		3324							
14	1500	107	1756		2140		2524		3107		3678		4501											
	1000	71	1165	156	1420	190	1675	224	2062	276	2440	326	2987	399	3337	446	3934	526	4517	604				
	750	54	874		1065		1256		1546		1830		2240		2503		2950		3388					
16	1500	94	1543		1881		2218		2730		3132		3833		4418									
	1000	63	1034	158	1260	193	1487	227	1830	280	2099	321	2569	393	2961	452	3491	533	4008	612				
	750	47	775		945		1115		1372		1574		1927		2220		2618		3006					
18	1500	83	1362		1660		1958		2410		2765		3385		3781		4458							
	1000	56	919	158	1120	193	1321	227	1626	280	1866	321	2284	393	2551	438	3008	517	3562	612	4344	747		
	750	42	689		840		991		1220		1399		1713		1913		2256		2672		3258			
20	1500	75	1231		1454		1770		2178		2499		3058		3416		4028		4626					
	1000	50	820	157	969	185	1180	225	1452	277	1665	318	2039	389	2277	435	2686	513	3084	589	3879	741	4377	
	750	38	615		727		885		1089		1249		1529		1708		2014		2313		2909		3282	
22.4	1500	67	1066				1532				2233				3052				4132					
	1000	45	715	153			1029	220			1499	321			2050	439			2775	594			3939	
	750	33	537				772				1124				1538				2081				2954	
25	1500	60																						
	1000	40																						
	750	30																						
28	1500	54																						
	1000	36																						
	750	27																						

采取强制润滑

Forced lubrication required



齿轮箱
热功率
类型 P2
规格 4-9

Gear Units
Ethermal Capacities
Type P2
Sizes 4-9

热功率 P_G (Kw)/Thermal capacities P_G (Kw)

i_N	n1	齿轮箱规格/Gear unit sizes (4-9)																	
		4			5			6			7			8			9		
		750	1000	1500	750	1000	1500	750	1000	1500	750	1000	1500	750	1000	1500	750	1000	1500
6.3	P_{GA}	52.8	54.1	48.5	64.9	66.5	48.8				99	90.3	*				128	116	*
	P_{GB}	88.8	106	132	120	143	172				183	221	256				242	293	322
	P_{GC}	103.8	120	146	164	190	226				267	305	357				416	475	542
	P_{GD}	134	162	210	212	256	327				341	417	525				511	626	774
7.1	P_{GA}	54.7	56.1	51.6	67.3	69	53.9				99	89.8	*				129	117	*
	P_{GB}	91.3	109	137	122	146	177				177	214	252				236	286	323
	P_{GC}	105	121	148	164	189	226				237	287	338				369	447	516
	P_{GD}	137	165	214	212	256	327				322	394	499				481	589	735
8	P_{GA}	53.1	54.4	51.4	66.7	68.3	56.4	72.7	74.5	59.2	98	89.1	64.9	109	99	*	130	118	*
	P_{GB}	87.1	104	132	119	142	175	132	157	191	172	208	249	194	235	276	230	279	322
	P_{GC}	99.5	115	140	158	182	219	170	197	236	238	272	323	273	312	367	372	425	496
	P_{GD}	128	155	202	203	245	316	220	266	341	307	376	479	350	428	542	459	562	707
9	P_{GA}	52.1	53.4	52.4	66.3	67.9	60.5	76.2	78.1	67.8	98	89.3	73.2	110	100	77.2	132	120	86.3
	P_{GB}	84.6	101	129	116	139	174	133	159	198	167	202	248	188	228	275	225	272	324
	P_{GC}	94.3	109	135	151	174	211	170	197	238	227	259	311	258	294	352	353	403	477
	P_{GD}	124	150	196	194	234	303	220	266	344	292	357	458	331	405	518	438	536	682
10	P_{GA}	47.1	51.1	51.4	60.3	65.4	61.1	71.4	77.4	70.9	86	88.3	77.7	98	100	84.2	116	119	96
	P_{GB}	80.2	95.7	123	110	131	165	131	156	196	159	193	241	183	222	273	216	262	320
	P_{GC}	88.3	102	126	138	160	196	164	189	230	213	243	295	245	280	338	331	378	453
	P_{GD}	115	139	182	180	217	282	211	255	331	275	337	436	315	386	498	412	505	648
11.2	P_{GA}	45.5	49.3	50.4	58.5	63.4	61.2	70.1	76	72.2	89	90.7	83.4	97	99	88	113	116	99.9
	P_{GB}	76.8	91.7	118	106	126	160	127	151	191	162	196	246	177	214	267	206	249	309
	P_{GC}	83.9	97	120	131	151	185	156	180	221	211	241	294	231	264	321	309	353	427
	P_{GD}	109	132	174	170	205	268	203	245	319	274	336	436	300	367	475	386	473	610
12.5	P_{GA}	44.1	47.8	49.5	58.1	63	62.1	66.7	72.3	70.5	88	90.2	85.6	93	95.6	88.3	113	116	104
	P_{GB}	73.4	87.6	113	103	123	157	119	142	181	158	191	242	169	205	258	202	244	305
	P_{GC}	81	93.6	116	129	149	183	143	165	204	207	236	289	219	250	305	300	342	415
	P_{GD}	104	126	166	166	201	263	187	226	295	267	327	425	283	346	450	372	455	589
14	P_{GA}	42	45.5	47.6	55.3	60	60.4	64.4	69.8	69.5	82	83.8	81.7	95	97.7	93.2	111	114	106
	P_{GB}	69.5	82.9	108	97.2	116	150	113	135	174	145	175	224	171	207	263	195	236	298
	P_{GC}	75.7	87.5	108	119	138	171	135	156	193	185	211	259	217	248	304	282	322	393
	P_{GD}	98	118	155	154	186	243	176	213	279	240	294	384	282	345	449	353	432	562
16	P_{GA}	38.5	41.8	44.1	52.2	56.6	57.8	63.5	68.9	69.8	77	79	78.6	95	97	94.9	105	108	104
	P_{GB}	63.4	75.7	98.9	90.5	108	140	110	131	169	135	163	210	166	201	257	183	221	281
	P_{GC}	68.2	78.8	98.1	109	126	157	133	154	191	170	194	239	212	242	297	258	295	362
	P_{GD}	89	107	141	142	171	225	172	208	273	220	269	352	274	336	438	324	397	518
18	P_{GA}	37	40.1	42.7	50.2	54.4	56.4	60.6	65.7	67.6	74	76.1	77.3	88	89.7	89.8	101	103	101
	P_{GB}	60.4	72.1	94.4	86.3	103	134	104	124	162	130	157	202	152	184	237	172	208	266
	P_{GC}	64.1	74.1	92.4	103	119	148	123	142	117	162	185	229	190	217	268	242	267	339
	P_{GD}	83	100	132	134	162	213	161	194	255	210	257	338	246	301	395	303	371	486
20	P_{GA}	36.2	39.3	42	47.1	51.1	53.3	56.9	61.7	64	70	71.3	73.1	83	85.2	86.3	98	100	100
	P_{GB}	58.8	70.2	92.1	81.1	96.8	126	96.4	115	150	120	145	188	145	172	222	165	200	257
	P_{GC}	62	71.1	89.4	96.1	111	138	113	131	162	148	169	209	174	199	247	231	264	326
	P_{GD}	81	97.4	128	124	150	198	148	179	235	193	236	310	225	276	363	290	355	465
22.4	P_{GA}	33.6	36.4	38.9	43.8	47.5	49.7	54.5	59	61.3	67	68.7	70.7	79	81.1	82.4	90	92.3	92.6
	P_{GB}	54.4	64.9	85.2	74.9	89.4	116	93	111	144	115	139	181	136	165	213	153	185	239
	P_{GC}	56.5	65.3	81.5	87.4	101	125	107	124	155	141	161	200	166	190	235	209	238	293
	P_{GD}	74	88.9	117	113	137	181	140	169	223	183	224	295	215	263	346	261	320	420
25	P_{GA}							51	55.3	57.6						74	75.8	77.2	
	P_{GB}							86.3	103	134						126	152	197	
	P_{GC}							98.7	114	142						152	174	216	
	P_{GD}							129	156	206						198	242	318	
28	P_{GA}							47.5	51.5	54.1						72	73.3	75.5	
	P_{GB}							80.3	95.8	125						121	146	190	
	P_{GC}							90	104	130						145	166	206	
	P_{GD}							118	142	187						188	230	302	

* 敬请垂询

P_{GA} (Kw) 齿轮箱不带辅助冷却措施
 P_{GB} (Kw) 齿轮箱带冷却风扇
 P_{GC} (Kw) 齿轮箱带内置冷却盘管
 P_{GD} (Kw) 齿轮箱带冷却风扇和内置冷却盘管

* On request

P_{GA} (Kw) Gear units without auxiliary cooling
 P_{GB} (Kw) Gear units with fan
 P_{GC} (Kw) Gear units with built-in cooling coil
 P_{GD} (Kw) Gear units with fan and built-in cooling coil



齿轮箱
热功率
类型 P2
规格 10-15

Gear Units
Thermal Capacities
Type P2
Sizes 10-15

		热功率 P_G (Kw)/Thermal capacities P_G (Kw)																	
i_N	n1	齿轮箱规格/Gear unit sizes (10-15)																	
		10			11			12			13			14			15		
		750	1000	1500	750	1000	1500	750	1000	1500	750	1000	1500	750	1000	1500	750	1000	1500
6.3	P_{GA}				148	134	*				*	*	*				*	*	*
	P_{GB}				372	450	428				490	579	442				476	563	*
	P_{GC}				610	696	746				1052	1201	1197				1293	1434	1267
	P_{GD}				777	951	1124				1281	1553	1739				1470	1782	1824
7.1	P_{GA}				160	145	*				*	*	*				*	*	*
	P_{GB}				375	454	453				498	588	493				500	591	338
	P_{GC}				559	677	740				1019	1163	1193				1256	1392	1289
	P_{GD}				760	931	1117				1246	1510	1728				1440	1746	1851
8	P_{GA}	132	120	*	167	152	*	177	161	*	*	*	*	*	*	*	*	*	*
	P_{GB}	240	290	328	371	449	469	420	509	501	500	591	537	555	656	580	519	613	422
	P_{GC}	414	472	545	566	646	720	775	884	961	973	1110	1171	1139	1263	1319	1216	1348	1306
	P_{GD}	505	618	772	731	895	1088	956	1170	1397	1200	1455	1700	1368	1658	1923	1399	1696	1860
9	P_{GA}	137	124	*	176	160	*	200	182	*	222	195	*	241	212	*	*	*	*
	P_{GB}	234	283	333	361	437	484	430	520	553	503	594	600	569	672	666	537	635	541
	P_{GC}	387	442	521	525	599	686	754	861	968	924	1055	1159	1104	1224	1335	1165	1292	1332
	P_{GD}	475	582	736	680	833	1033	938	1149	1405	1151	1395	1679	1329	1611	1927	1356	1644	1889
10	P_{GA}	122	125	95.3	160	164	*	188	193	*	212	209	*	237	234	*	203	200	*
	P_{GB}	230	278	335	350	424	489	426	516	577	497	587	631	569	673	715	542	640	612
	P_{GC}	370	422	503	494	564	657	719	821	943	875	999	1128	1053	1167	1309	1104	1224	1316
	P_{GD}	454	556	710	642	786	987	903	1106	1375	1094	1326	1628	1280	1551	1896	1296	1571	1861
11.2	P_{GA}	121	124	103	169	173	119	190	195	*	229	226	*	250	247	*	221	218	*
	P_{GB}	223	270	331	355	430	509	409	495	572	509	601	674	563	665	738	535	632	648
	P_{GC}	349	398	479	491	560	662	662	756	882	864	986	1135	1004	1113	1274	1035	1148	1269
	P_{GD}	431	528	679	640	784	995	833	1020	1283	1088	1319	1642	1223	1482	1838	1225	1485	1796
12.5	P_{GA}	119	122	106	174	178	135	189	194	*	229	226	*	255	252	*	238	235	*
	P_{GB}	214	259	322	351	425	512	392	475	562	484	572	660	548	648	742	539	637	685
	P_{GC}	329	375	454	481	549	655	622	710	837	794	906	1056	943	1046	1215	1017	1128	1272
	P_{GD}	407	498	644	626	766	978	784	960	1218	1000	1212	1523	1156	1401	1755	1204	1459	1790
14	P_{GA}	116	119	108	169	173	142	197	202	153	228	225	*	269	266	*	243	240	*
	P_{GB}	204	247	310	333	403	494	399	483	583	463	547	647	558	659	774	520	614	686
	P_{GC}	306	349	425	446	509	611	618	705	841	736	840	991	935	1037	1220	946	1049	1205
	P_{GD}	380	465	603	581	711	914	782	958	1223	933	1131	1434	1148	1392	1761	1126	1365	1697
16	P_{GA}	114	117	110	162	166	144	201	206	169	215	212	160	266	263	193	255	252	*
	P_{GB}	198	240	303	311	377	469	393	476	583	424	501	603	530	626	751	522	617	710
	P_{GC}	297	339	414	407	464	561	603	688	827	652	744	887	854	947	1125	926	1027	1196
	P_{GD}	367	449	584	531	650	839	761	932	1197	831	1007	1286	1053	1276	1626	1106	1341	1684
18	P_{GA}	111	114	111	152	156	143	195	200	175	222	219	181	262	259	209	251	248	170
	P_{GB}	191	231	296	291	352	443	372	450	560	428	506	621	506	598	731	493	583	690
	P_{GC}	280	319	392	379	432	527	556	635	769	655	747	899	795	881	1057	854	947	1119
	P_{GD}	347	425	555	497	609	790	706	864	1115	832	1009	1297	981	1189	1526	1026	1244	1578
20	P_{GA}	106	109	107	148	152	142	185	189	170	211	208	179	242	239	202	245	242	179
	P_{GB}	179	217	278	280	339	428	346	419	525	400	473	586	459	543	670	469	554	665
	P_{GC}	257	293	362	357	408	499	506	577	702	597	681	823	704	780	941	786	871	1036
	P_{GD}	320	392	512	470	575	747	642	786	1019	761	923	1191	871	1056	1360	942	1142	1455
22.4	P_{GA}	100	102	101	139	142	133	171	175	159				244	241	206			
	P_{GB}	168	203	261	259	314	397	322	390	489				460	544	673			
	P_{GC}	239	273	337	325	371	454	473	540	657				704	780	942			
	P_{GD}	299	366	478	428	524	682	601	736	954				872	1057	1362			
25	P_{GA}	97	99.4	98.9				166	170	155				230	227	195			
	P_{GB}	162	196	252				309	374	470				428	506	627			
	P_{GC}	162	196	252				443	506	617				643	713	862			
	P_{GD}	230	262	323				565	692	898				796	965	1245			
28	P_{GA}	90	92.5	93.4				156	160	150									
	P_{GB}	150	182	235				287	347	439									
	P_{GC}	207	236	292				402	459	562									
	P_{GD}	260	318	417				515	630	819									

* 敬请垂询
 P_{GA} (KW) 齿轮箱不带辅助冷却措施
 P_{GB} (KW) 齿轮箱带冷却风扇
 P_{GC} (KW) 齿轮箱带内置冷却盘管
 P_{GD} (KW) 齿轮箱带冷却风扇和内置冷却盘管

* On request
 P_{GA} (KW) Gear units without auxiliary cooling
 P_{GB} (KW) Gear units with fan
 P_{GC} (KW) Gear units with built-in cooling coil
 P_{GD} (KW) Gear units with fan and built-in coil

齿轮箱

热功率

类型 P2

规格 16-22

Gear Units

Thermal Capacities

Type P2

Sizes 16-22

		热功率 P_G (Kw)/Thermal capacities P_G (Kw)																					
i_N	n1	齿轮箱规格/Gear unit sizes (16-22)																					
		16			17			18			19			20			21			22			
		750	1000	1500	750	1000	1500	750	1000	1500	750	1000	1500	750	1000	1500	750	1000	1500	750	1000	1500	
6.3	P_{GA}				*	*	*					*	*	*				*	*	*	*	*	*
	P_{GB}				529	625	*					*	*	*				*	*	*	*	*	*
	P_{GC}				1583	1736	1410					*	*	*				*	*	*	*	*	*
	P_{GD}				1848	2240	2151					*	*	*				*	*	*	*	*	*
7.1	P_{GA}	*	*	*	*	*	*	*	*	*	*	*	*	*	*	*	*	*	*	*	*	*	
	P_{GB}	498	589	*	578	683	*	558	659	*	*	*	*	*	*	*	*	*	*	*	*	*	
	P_{GC}	1306	1448	1305	1540	1689	1458	1584	1737	1443	*	*	*	*	*	*	*	*	*	*	*	*	
	P_{GD}	1493	1810	1880	1803	2186	2199	1865	2260	2209	*	*	*	*	*	*	*	*	*	*	*	*	
8	P_{GA}	*	*	*	*	*	*	*	*	*	*	*	*	*	*	*	*	*	*	*	*	*	
	P_{GB}	525	620	390	620	733	*	608	719	*	*	*	*	*	*	*	*	*	*	*	*	*	
	P_{GC}	1269	1407	1332	1504	1649	1507	1544	1693	1500	*	*	*	*	*	*	*	*	*	*	*	*	
	P_{GD}	1432	1772	1910	1777	2154	2261	1817	2203	2260	*	*	*	*	*	*	*	*	*	*	*	*	
9	P_{GA}	*	*	*	*	*	*	*	*	*	*	*	*	*	*	*	*	*	*	*	*	*	
	P_{GB}	554	655	530	665	786	584	668	789	542	*	*	*	*	*	*	*	*	*	*	*	*	
	P_{GC}	1232	1366	1386	1469	1611	1593	1515	1662	1608	*	*	*	*	*	*	*	*	*	*	*	*	
	P_{GD}	1432	1736	1970	1749	2120	2360	1808	2191	2400	*	*	*	*	*	*	*	*	*	*	*	*	
10	P_{GA}	200	198	*	*	*	*	*	*	*	*	*	*	*	*	*	*	*	*	*	*	*	
	P_{GB}	565	668	617	687	812	710	702	830	691	*	*	*	*	*	*	*	*	*	*	*	*	
	P_{GC}	1175	1303	1383	1411	1548	1611	1469	1611	1649	*	*	*	*	*	*	*	*	*	*	*	*	
	P_{GD}	1381	1674	1964	1469	2053	2374	1768	2143	2447	*	*	*	*	*	*	*	*	*	*	*	*	
11.2	P_{GA}	225	222	*	232	229	*	226	223	*	*	*	*	*	*	*	*	*	*	*	*	*	
	P_{GB}	566	669	669	690	815	784	717	847	787	*	*	*	*	*	*	*	*	*	*	*	*	
	P_{GC}	1116	1237	1354	1338	1468	1582	1416	1553	1651	*	*	*	*	*	*	*	*	*	*	*	*	
	P_{GD}	1315	1594	1913	1615	1958	2323	1708	2070	2431	*	*	*	*	*	*	*	*	*	*	*	*	
12.5	P_{GA}	238	235	*	263	260	*	253	250	*	317	301	*	304	289	*	*	*	*	*	*	*	
	P_{GB}	555	656	691	705	833	851	714	844	840	*	*	*	*	*	*	*	*	*	*	*	*	
	P_{GC}	1050	1164	1302	1304	1430	1579	1340	1470	1605	*	*	*	*	*	*	*	*	*	*	*	*	
	P_{GD}	1242	1506	1836	1579	1914	2311	1621	1965	2355	*	*	*	*	*	*	*	*	*	*	*	*	
14	P_{GA}	255	252	*	277	274	*	285	281	*	345	328	*	350	333	*	*	*	*	*	*	*	
	P_{GB}	558	659	726	689	814	875	728	860	906	*	*	*	*	*	*	*	*	*	*	*	*	
	P_{GC}	1026	1138	1298	1221	1339	1511	1305	1431	1600	*	*	*	*	*	*	*	*	*	*	*	*	
	P_{GD}	1223	1482	1832	1487	1802	2211	1585	1921	2342	*	*	*	*	*	*	*	*	*	*	*	*	
16	P_{GA}	257	254	*	284	280	*	296	292	*	359	341	*	372	354	*	353	336	*	*	*	*	
	P_{GB}	536	634	721	662	782	873	708	837	919	*	*	*	*	*	*	*	*	*	*	*	*	
	P_{GC}	955	1059	1226	1135	1245	1429	1223	1341	1528	*	*	*	*	*	*	*	*	*	*	*	*	
	P_{GD}	1139	1381	1726	1386	1680	2088	1493	1810	2236	*	*	*	*	*	*	*	*	*	*	*	*	
18	P_{GA}	271	268	*	296	292	*	303	299	*	381	362	*	387	368	*	386	367	*	370	352	*	
	P_{GB}	540	638	748	650	768	888	681	805	919	*	*	*	*	*	*	*	*	*	*	*	*	
	P_{GC}	935	1037	1219	1084	1189	1387	1133	1243	1442	*	*	*	*	*	*	*	*	*	*	*	*	
	P_{GD}	1121	1359	1718	1325	1606	2020	1393	1689	2114	*	*	*	*	*	*	*	*	*	*	*	*	
20	P_{GA}	261	258	182	297	293	*	308	304	*	380	361	*	398	378	*	392	373	*	391	372	*	
	P_{GB}	507	599	712	635	751	882	666	787	915	*	*	*	*	*	*	*	*	*	*	*	*	
	P_{GC}	863	957	1133	1039	1140	1342	1077	1181	1382	*	*	*	*	*	*	*	*	*	*	*	*	
	P_{GD}	1037	1257	1597	1275	1546	1956	1322	1602	2019	*	*	*	*	*	*	*	*	*	*	*	*	
22.4	P_{GA}	251	248	179				304	300	*				388	369	*				381	362	*	
	P_{GB}	479	566	676				646	764	893				*	*	*				*	*	*	
	P_{GC}	791	877	1041				1033	1133	1329				*	*	*				*	*	*	
	P_{GD}	951	1153	1467				1268	1537	1939				*	*	*				*	*	*	
25	P_{GA}																						
	P_{GB}																						
	P_{GC}																						
	P_{GD}																						
28	P_{GA}																						
	P_{GB}																						
	P_{GC}																						
	P_{GD}																						

* 敬请垂询

P_{GA} (KW) 齿轮箱不带辅助冷却措施
 P_{GB} (KW) 齿轮箱带冷却风扇
 P_{GC} (KW) 齿轮箱带内置冷却盘管
 P_{GD} (KW) 齿轮箱带冷却风扇和内置冷却盘管

* On request

P_{GA} (KW) Gear units without auxiliary cooling
 P_{GB} (KW) Gear units with fan
 P_{GC} (KW) Gear units with built-in cooling coil
 P_{GD} (KW) Gear units with fan and built-in coil



齿轮箱

公称功率和输出扭矩

类型 P3

规格 5-15

Gear Units

Norminal Power Rating and output Torque

Type P3

Sizes 5-15

i _N	n1	n2	公称功率P _{2N} (Kw) 和工程输出扭矩T _{2N} (KN.m) /Nominal power ratings P _{2N} (Kw)and output torque T _{2N} (KN.m)																							
			5		6		7		8		9		10		11		12		13		14		15			
			P _{2N}	T _{2N}	P _{2N}	T _{2N}	P _{2N}	T _{2N}	P _{2N}	T _{2N}	P _{2N}	T _{2N}	P _{2N}	T _{2N}	P _{2N}	T _{2N}	P _{2N}	T _{2N}	P _{2N}	T _{2N}	P _{2N}	T _{2N}	P _{2N}	T _{2N}		
22.4	1500	67																	648				1127	162		
	1000	45																	435	93.0					756	
	750	33																	326						567	
25	1500	60	76				143				235					418			580				1009	160		
	1000	40	50	12.0			95	22.6			156	37.4			278	66.4			386	92.3					672	
	750	30	38				71				117				209				290						504	
28	1500	54	68				128				211				377			522			647		908	162		
	1000	36	45	12.1			85	22.7			141	37.6			251	67.1			348	92.9	431	115			605	
	750	27	34				64				106				188				261						454	
31.5	1500	61	61			81		114		143		188		231		335		407		464		574		807	162	
	1000	40	40	12.0	54	16.1	76	22.7		96	28.7	125	37.6	153	46.1	223	67.0	271	81.5	309	92.9	383	115			538
	750	30	30		40		57			72		94		115		167		203		232		287				403
35.5	1500	42	54		71		100		125		165		202		293		356		406		503		706	159		
	1000	28	36	12.1	47	16.0	66	22.4		83	28.1	109	37.0	134	45.6	195	66.2	237	80.5	271	91.8	335	114			470
	750	21	27		35		50			62		82		101		146		178		203		251				353
40	1500	38	45		60		84		106		139		171		247		301		343		424		596	150		
	1000	25	29	11.2	39	15.0	55	21.0		70	26.6	91	34.8	112	42.7	163	62.1	198	75.6	225	86.1	279	107			392
	750	19	22		29		41			52		68		84		122		148		169		209				294
45	1500	33	39		52		73		91		121		148		215		261		298		368		517	148		
	1000	22	25	11.0	34	14.7	48	20.6		61	26.1	80	34.5	98	42.1	143	61.5	173	74.5	198	85.1	246	106			345
	750	17	19		26		36			46		60		74		107		130		148		184				259
50	1500	30	35		47		67		83		110		134		195		237		270		335		470	150		
	1000	20	24	11.2	31	15.0	44	21.1		55	26.2	73	34.6	89	42.6	129	61.8	158	75.3	180	86.1	223	107			314
	750	15	18		24		33			41		54		67		97		118		135		168				235
56	1500	27	31		42		60		74		98		121		175		214		243		302		423	150		
	1000	18	21	11.0	28	15.2	39	21.0		49	26.2	65	34.6	80	43.0	117	62.4	141	75.5	161	86.0	200	107			280
	750	13	15		21		29			37		49		60		87		106		121		150				210
63	1500	24	28		37		53		67		87		108		156		190		217		268		376	150		
	1000	16	19	11.2	25	14.7	35	21.2		44	26.5	58	34.8	71	42.5	103	61.9	125	75.5	143	86.1	177	107			249
	750	12	14		18		26			33		43		53		77		94		107		133				187
71	1500	21	24		32		45		56		74		91		132		161		183		227		319	145		
	1000	14	26	11.0	21	14.2	30	20.6		38	25.8	49	33.5	61	41.2	88	59.9	107	72.8	123	83.1	152	103			214
	750	11	12		16		23			29		37		46		66		81		92		114				160
80	1500	19	21		29		40		50		67		82		119		143		164		203		286	145		
	1000	13	14	10.9	19	14.5	27	20.3		33	25.4	44	33.4	54	41.4	79	60.2	96	73.3	109	83.5	135	103			190
	750	9.4	11		14		20			25		33		41		59		72		82		101				143
90	1500	17	19		26		32		45		57		72		105		127		145		181		254	145		
	1000	11	12	10.6	17	14.7	22	18.8		29	25.3	38	32.7	48	40.8	69	59.6	85	72.7	97	83.3	120	103			168
	750	8.3	9		13		16			22		29		36		52		63		73		90				126
100	1500	15			21				40				65				115					162			103	
	1000	10			14	13.6			27	25.4			43	40.8			76	72.6				108				
	750	7.5			11				20				32				57					81				
112	1500	13			20				33				57				103					144			103	
	1000	8.9			12	13.2			22	23.4			37	39.6			67	72.1				96				
	750	6.7			9				16				28				51					72				

采取强制润滑

Forced lubrication required



齿轮箱
公称功率和输出扭矩
类型 P3
规格 16-26

Gear Units
Normal Power Rating and output Torque
Type P3
Sizes 16-26

i _N	n1	n2	公称功率P _{2N} (Kw) 和工程输出扭矩T _{2N} (KN.m) /Nominal power ratings P _{2N} (Kw)and output torque T _{2N} (KN.m)																							
			16		17		18		19		20		21		22		23		24		25		26			
			P _{2N}	T _{2N}	P _{2N}	T _{2N}	P _{2N}	T _{2N}	P _{2N}	T _{2N}	P _{2N}	T _{2N}	P _{2N}	T _{2N}	P _{2N}	T _{2N}	P _{2N}	T _{2N}	P _{2N}	T _{2N}	P _{2N}	T _{2N}	P _{2N}	T _{2N}		
22.4	1500	67			1473				2209				3093				4124									
	1000	45			989	212			1484	317			2078	445			2770	593			3957	847				
	750	33			742				1113				1558				2077				2968					
25	1500	60	1140		1319		1582		1978		2275		2770		3100		3694		4221							
	1000	40	760	181	879	210	1055	252	1319	315	1517	362	1847	441	2066	493	2462	588	2814	672	3518	840	3957	945		
	750	30	570		659		791		989		1138		1385		1550		1847		2111		2638		2968			
28	1500	54	1027		1187		1425		1781		2048		2493		2790		3324		3799		4749					
	1000	36	685	183	791	211	949	254	1187	317	1365	365	1662	444	1860	497	2216	592	2533	677	3166	847	3562	952		
	750	27	513		593		712		890		1024		1247		1395		1662		1899		2374		2671			
31.5	1500	61	912		1055		1266		1582		1821		2216		2480		2955		3377		4221		4749			
	1000	40	608	183	704	212	844	254	1055	317	1214	365	1477	444	1653	497	1970	593	2251	677	2814	847	3166	952		
	750	30	456		528		633		791		910		1108		1240		1477		1688		2111		2374			
35.5	1500	42	798		923		1108		1385		1593		1939		2170		2585		2955		3694		4156			
	1000	28	532	180	615	209	738	250	923	313	1062	360	1293	438	1447	491	1723	584	1970	668	2462	835	2770	939		
	750	21	399		461		554		692		796		969		1085		1292		1477		1847		2077			
40	1500	38	674		779		935		1169		1345		1638		1833		2183		2495		3119		3509			
	1000	25	443	169	513	196	615	235	769	294	885	338	1077	411	1205	460	1436	548	1642	627	2052	784	2309	882		
	750	19	332		384		462		577		664		808		904		1077		1231		1539		1732			
45	1500	33	585		677		812		1015		1168		1422		1592		1896		2167		2709		3047			
	1000	22	390	168	451	194	541	232	677	291	778	334	948	407	1060	456	1264	543	1445	621	1805	776	2032	873		
	750	16.7	293		338		406		508		584		711		795		948		1083		1354		1524			
50	1500	30	532		615		738		923		1061		1293		1446		1724		1970		2463		2770			
	1000	20	355	169	410	196	492	235	615	294	708	338	861	411	964	460	1149	548	1313	627	1642	784	1846	882		
	750	15	266		307		369		462		531		646		723		861		985		1231		1385			
56	1500	27	479		554		664		831		956		1163		1301		1551		1773		2216		2493			
	1000	17.9	318	170	367	196	440	235	551	295	633	339	771	412	862	461	1028	550	1175	628	1469	786	1652	884		
	750	13.4	238		275		330		413		475		578		647		771		881		1102		1239			
63	1500	24	425		492		591		738		850		1034		1157		1379		1576		1970		2216			
	1000	15.9	282	170	325	196	391	235	489	294	563	338	685	412	766	461	913	550	1044	628	1304	785	1468	883		
	750	11.9	212		244		293		367		432		514		575		685		783		978		1101			
71	1500	21	361		417		501		626		720		877		981		1169		1337		1671		1880			
	1000	14.1	242	164	280	190	336	228	420	285	484	328	589	399	658	446	785	532	897	608	1122	761	1262	855		
	750	10.6	182		210		252		315		363		442		494		589		673		841		946			
80	1500	18.8	323		373		448		561		645		785		879		1047		1196		1495		1682			
	1000	12.5	215	164	248	189	298	228	372	285	428	327	522	398	584	446	695	531	795	607	995	760	1119	855		
	750	9.4	161		186		224		279		321		391		438		522		596		746		839			
90	1500	16.7	287		332		398		482		573		680		780		930		1063		1328		1494			
	1000	11.1	191	164	220	189	264	227	320	275	380	327	452	389	519	446	618	531	706	607	883	759	994	854		
	750	8.3	143		165		198		240		285		339		389		463		529		662		745			
100	1500	15	257				336				500				694				955				1324			
	1000	10	172	164			224	214			333	318			462	441			637	608			895	855		
	750	7.5	129				168				249				346				477				671			

采取强制润滑

Forced lubrication required



齿轮箱
热功率
类型 P3
规格 5-10

Gear Units
Thermal Capacities
Type P3
Sizes 5-10

热功率P_G (Kw)/Thermal capacities P_G (Kw)

i _N	n ₁	齿轮箱规格/Gear unit sizes (5-10)																	
		5			6			7			8			9			10		
		750	1000	1500	750	1000	1500	750	1000	1500	750	1000	1500	750	1000	1500	750	1000	1500
22.4	P _{GA}																		
	P _{GB}																		
	P _{GC}																		
	P _{GD}																		
25	P _{GA}	46.0	49.9	52.5				68.5	73.5	76.1				92.6	99.3	100			
	P _{GB}	62.1	73.4	92.4				90.9	110	138				126	152	187			
	P _{GC}	91.1	105	130				147	169	208				214	247	302			
	P _{GD}	103	125	163				164	201	261				239	293	378			
28	P _{GA}	44.3	48	50.9				69.2	74.2	77.5				92.3	99	101			
	P _{GB}	59.8	70.7	89.4				92.5	112	140				124	150	186			
	P _{GC}	86.5	99.7	123				145	167	207				207	239	294			
	P _{GD}	97.7	118	155				163	200	261				232	284	368			
31.5	P _{GA}	43.1	46.7	49.9	49.8	54	57.4	66.6	71.4	75.3	73.8	79.1	82.8	90.4	96.9	100	93.3	100	102
	P _{GB}	57.9	68.5	86.9	66.5	78.6	99.6	88.4	107	135	97.5	118	148	121	146	183	125	151	188
	P _{GC}	83.0	95.6	118	94.6	109	135	137	158	195	150	173	214	200	230	283	248	286	352
	P _{GD}	94.3	114	149	108	130	170	155	190	248	168	206	268	223	273	355	272	333	432
35.5	P _{GA}	41.7	45.2	48.6	47.9	51.9	55.7	64.7	69.4	73.9	74.3	79.7	84.4	87.6	93.9	98.7	93.1	99.8	104
	P _{GB}	56.0	66.2	84.3	63.9	75.6	96.2	85.9	104	132	98.3	119	150	117	142	178	123	149	186
	P _{GC}	79.2	91.3	113	89.4	103	127	131	151	188	148	171	211	190	219	271	241	278	343
	P _{GD}	90.2	109	143	102	123	161	149	183	239	167	205	268	214	262	342	264.6	324	421
40	P _{GA}	39.4	42.7	46.1	46.5	50.4	54.3	61.6	66	70.6	71.4	76.6	81.4	82.9	88.9	93.9	90	96.5	101
	P _{GB}	52.7	62.3	79.5	62.0	73.3	93.4	81.7	98.9	125	98.1	113	144	111	134	170	120	145	182
	P _{GC}	73.6	84.8	105	85.8	98.8	122	122	141	175	140	161	200	177	204	252	230	265	327
	P _{GD}	83.6	101	133	96.8	117	154	139	170	223	158	1944	254	199	244	319	253	310	404
45	P _{GA}	37.6	40.8	44.2	44.9	48.7	52.5	59.3	63.6	68.2	69.3	74.3	79.2	79.8	85.6	90.8	87.7	94	99.1
	P _{GB}	50.4	59.6	76.1	59.8	70.7	90.2	78.5	95	120	90.9	110	140	106	128	162	116	141	177
	P _{GC}	69.5	80.1	99.7	81.9	94.4	117	116	134	167	135	155	192	168	193	239	220	254	314
	P _{GD}	79.4	96	126	93.5	113	148	132	162	212	152	186	243	189	232	303	243	298	388
50	P _{GA}	36.5	39.6	43.2	42.5	46.1	50.1	56.0	60.1	65.2	66.1	70.9	76.6	78.5	84.2	90.6	83.4	89.4	95.9
	P _{GB}	48.6	57.5	73.8	56.4	66.7	87.5	74.0	89.6	114	85.9	104	133	104	126	160	110	133	169
	P _{GC}	67.1	77.3	96.4	76.1	87.7	109	109	126	157	126	145	181	164	189	235	205	236	293
	P _{GD}	76.8	92.8	122	86.9	105	138	124	152	200	142	174	228	184	225	295	226	277	362
56	P _{GA}	34.7	37.6	41.2	40.9	44.3	48.5	53.6	57.5	62.7	63.8	68.4	74.4	75.0	80.4	87.3	80.4	86.2	93.4
	P _{GB}	46.1	54.5	70.1	54.0	63.9	82.2	70.4	85.2	109	82.6	100	129	99.1	120	153	106	128	164
	P _{GC}	63.0	72.6	90.6	72.0	83	103	102	118	148	120	138	172	153	176	219	194	223	278
	P _{GD}	71.8	86.7	114	82.5	99.7	131	117	143	188	136	166	218	173	212	278	214	262	344
63	P _{GA}	32.7	35.5	39.1	39.4	42.7	47	50.1	53.7	59	60.3	64.7	71	71.2	76.2	83.5	78.9	84.6	92.5
	P _{GB}	43.3	51.2	66.1	51.9	61.4	79.2	65.6	79.4	102	78.6	95.1	122	92.5	112	145	102	124	160
	P _{GC}	58.4	67.3	84.1	69.5	80.1	100	94.6	109	136	112	129	161	141	163	204	189	218	272
	P _{GD}	66.7	80.6	106	79.6	96.2	126	106	130	172	127	156	205	161	197	259	210	257	338
71	P _{GA}	32.4	35.1	38.7	37.4	40.5	44.6	48.6	52.1	57.3	57.4	61.6	67.7	69.6	74.6	81.8	75.1	80.5	88.2
	P _{GB}	42.8	50.6	65.3	49.1	58.1	75	63.4	76.7	98.9	74.7	90.4	116	90.9	110	142	98.3	119	153
	P _{GC}	57.7	66.5	83.1	65.2	75.1	93.8	90.3	104	130	104	120	151	139	160	200	177	204	255
	P _{GD}	66.0	79.7	105	74.4	89.9	118	103	126	166	118	145	192	156	191	252	195	239	315
80	P _{GA}	30.7	33.3	36.8	35.2	38.2	42.1	47.5	50.9	56	53.7	57.6	63.3	65.8	70.6	77.6	71.0	76.1	83.5
	P _{GB}	40.5	47.9	61.9	46.1	54.5	70.3	61.9	74.9	96.6	69.5	84.1	108	85.9	104	134	91.7	111	143
	P _{GC}	53.6	61.8	77.3	60.5	69.7	87.2	86.8	100	125	96.3	111	139	128	148	185	164	189	236
	P _{GD}	61.4	74.2	97.9	69.2	83.6	110	98.8	121	160	109	134	177	146	179	236	181	222	293
90	P _{GA}	30.3	32.9	36.3	34.9	37.8	41.8	44.9	48.1	53.1	51.9	55.7	61.4	62.6	67.1	73.8	69.3	74.3	81.6
	P _{GB}	40.0	47.3	61.1	45.7	54.1	69.8	58.4	70.7	91.3	67.0	81.1	104	81.6	98.8	127	89.2	108	140
	P _{GC}	52.2	60.1	75.1	60.0	69.1	86.4	80.8	93.1	116	92.9	107	133	120	138	172	161	185	231
	P _{GD}	59.8	72.3	95.5	68.5	82.8	109	91.5	112	148	105	129	171	136	166	219	177	217	286
100	P _{GA}				33.1	35.9	39.7							50.9	54.6	60.4			65.9
	P _{GB}				43.3	51.2	66.2							65.7	79.5	102			85.1
	P _{GC}				55.7	64.2	80.3							89.4	103	129			149
	P _{GD}				63.9	77.2	101							102	125	165			165
112	P _{GA}				32.7	35.5	39.3							48.2	51.7	57.2			62.7
	P _{GB}				42.9	50.7	65.6							62.1	75.2	97.3			81.2
	P _{GC}				54.2	62.5	78.3							83.1	95.8	119			138
	P _{GD}				62.2	75.2	99.4							94.7	116	153			154

* 敬请垂询

P_{GA}(KW) 齿轮箱不带辅助冷却措施
 P_{GB}(KW) 齿轮箱带冷却风扇
 P_{GC}(KW) 齿轮箱带内置冷却盘管
 P_{GD}(KW) 齿轮箱带冷却风扇和内置冷却盘管

* On request

P_{GA}(KW) Gear units without auxiliary cooling
 P_{GB}(KW) Gear units with fan
 P_{GC}(KW) Gear units with built-in cooling coil
 P_{GD}(KW) Gear units with fan and built-in coil



齿轮箱
热功率
类型 P3
规格 11-16

Gear Units
Thermal Capacities
Type P3
Sizes 11-16

热功率Pg(KW)/Thermal capacities Pg(KW)																			
iN	n1	齿轮箱规格/Gear unit sizes (11-16)																	
		11			12			13			14			15			16		
		750	1000	1500	750	1000	1500	750	1000	1500	750	1000	1500	750	1000	1500	750	1000	1500
22.4	PGA							189	196	169				249	258	193			
	PGB							256	303	346				366	432	463			
	PGC							487	561	668				784	903	1050			
	PGD							536	650	811				860	1043	1267			
25	PGA	135	145	138				184	191	167				244	253	192	256	265	193
	PGB	190	230	275				249	294	338				355	420	453	375	443	470
	PGC	364	419	507				463	533	636				738	850	992	792	913	1059
	PGD	402	492	626				509	617	771				813	986	1201	870	1055	1277
28	PGA	132	142	137				180	186	169	207	214	191	245	254	206	255	264	207
	PGB	183	222	268				242	286	334	277	327	380	353	417	463	367	434	475
	PGC	340	392	477				434	500	600	509	586	701	712	820	966	746	860	1008
	PGD	379	464	593				481	583	734	561	680	854	790	957	1179	824	999	1224
31.5	PGA	129	138	137	153	164	159	178	184	173	204	211	196	243	252	217	256	265	222
	PGB	178	215	263	211	255	308	236	279	332	270	319	377	348	411	468	366	432	487
	PGC	325	374	457	374	431	523	417	480	580	483	556	670	680	783	930	720	829	981
	PGD	362	443	570	416	509	650	462	560	710	534	647	819	757	917	1143	799	969	1202
35.5	PGA	125	134	135	148	159	158	174	180	175	199	206	198	235	244	222	255	264	235
	PGB	172	208	257	203	246	300	229	271	328	263	311	374	334	395	461	360	425	493
	PGC	307	354	434	350	403	492	396	456	555	454	523	634	629	725	870	687	792	948
	PGD	345	422	544	392	480	617	441	534	683	505	612	781	705	854	1075	771	934	1171
40	PGA	120	129	132	145	155	156	168	174	172	194	201	197	229	237	221	244	253	232
	PGB	164	199	248	197	238	293	221	261	318	256	302	366	322	380	449	344	406	476
	PGC	289	333	410	333	384	470	374	431	525	433	499	608	593	683	823	637	734	882
	PGD	324	397	514	373	457	589	417	506	649	483	586	750	667	809	1024	715	867	1094
45	PGA	119	128	132	139	149	151	161	167	166	187	194	192	229	237	223	236	245	227
	PGB	164	199	247	189	229	283	212	250	306	246	291	355	320	378	450	330	390	460
	PGC	283	326	401	316	364	447	352	405	495	412	475	579	581	669	809	601	693	835
	PGD	318	389	505	354	434	561	392	475	611	460	557	714	654	793	1006	674	817	1034
50	PGA	118	127	134	135	145	151	160	166	171	183	190	195	233	241	240	240	249	246
	PGB	161	195	246	183	222	278	207	245	306	239	283	352	320	378	462	333	393	479
	PGC	277	319	395	299	344	425	342	394	485	389	448	551	575	662	809	588	678	827
	PGD	311	381	497	336	411	534	384	465	603	436	529	686	648	785	1009	664	805	1033
56	PGA	110	118	127	135	145	154	155	161	170	177	183	192	224	232	239	241	250	256
	PGB	150	181	230	183	221	280	201	238	300	229	271	341	305	361	449	330	390	484
	PGC	251	289	359	292	337	417	324	373	461	365	421	521	536	617	759	581	669	822
	PGD	282	345	452	329	403	527	364	441	574	412	499	650	606	735	952	656	795	1028
63	PGA	105	113	122	133	143	154	149	154	166	174	180	194	214	222	235	234	242	255
	PGB	141	171	219	178	216	276	191	226	288	224	265	338	290	343	434	317	375	473
	PGC	233	268	334	286	330	411	301	347	432	356	410	510	495	570	706	540	622	770
	PGD	262	321	421	323	395	518	339	411	538	401	486	637	562	681	889	615	746	973
71	PGA	103	110	120	124	133	144	145	150	162	168	174	188	208	216	230	221	229	243
	PGB	137	166	213	165	200	256	185	219	279	216	255	325	282	333	422	299	353	447
	PGC	224	258	322	259	298	371	287	331	412	338	389	484	476	548	680	501	577	715
	PGD	252	309	407	292	357	469	324	393	515	380	461	605	540	655	857	569	690	902
80	PGA	97	104	113	117	125	136	140	145	158	159	165	178	201	208	223	214	222	237
	PGB	129	156	201	155	188	241	180	213	272	204	241	308	271	320	406	289	342	434
	PGC	207	238	297	240	277	345	277	319	398	313	361	449	449	517	642	482	555	688
	PGD	234	286	377	271	332	437	312	378	496	354	429	564	512	620	812	547	663	868
90	PGA	93	100	110	115	123	134	131	136	148	154	160	173	189	196	211	208	215	231
	PGB	125	151	194	151	183	235	168	199	255	197	233	298	255	301	383	278	328	418
	PGC	198	228	285	231	267	333	254	293	365	299	345	430	416	479	595	455	524	651
	PGD	225	275	362	262	321	422	287	348	458	337	409	537	473	573	752	518	628	823
100	PGA				108	116	128						151	156	171				221
	PGB				143	173	223						192	227	293				397
	PGC				214	247	308						288	332	415				604
	PGD				243	297	392						325	394	520				764
112	PGA				104	112	124						141	146	161				
	PGB				139	168	216						180	213	274				
	PGC				206	237	296						266	306	382				
	PGD				234	286	377						300	364	479				

* 敬请垂询
PGA(KW) 齿轮箱不带辅助冷却措施
PGB(KW) 齿轮箱带冷却风扇
PGC(KW) 齿轮箱带内置冷却盘管
PGD(KW) 齿轮箱带冷却风扇和内置冷却盘管

* On request
PGA(KW) Gear units without auxiliary cooling
PGB(KW) Gear units with fan
PGC(KW) Gear units with built-in cooling coil
PGD(KW) Gear units with fan and built-in cooling coil



齿轮箱
热功率
类型 P3
规格 17-22

Gear Units
Thermal Capacities
Type P3
Sizes 17-22

热功率 P_G (Kw)/Thermal capacities P_G (Kw)																			
iN	n1	齿轮箱规格/Gear unit sizes (17-22)																	
		17			18			19			20			21			22		
		750	1000	1500	750	1000	1500	750	1000	1500	750	1000	1500	750	1000	1500	750	1000	1500
22.4	PGA	261	270	180				317	325	*				342	350	*			
	PGB	372	440	450				*	*	*				*	*	*			
	PGC	784	903	1035				*	*	*				*	*	*			
	PGD	849	1029	1228				*	*	*				*	*	*			
25	PGA	254	263	180	266	276	*	315	323	*	325	333	*	354	363	*	335	343	*
	PGB	361	427	442	382	451	455	*	*	*	*	*	*	*	*	*	*	*	*
	PGC	739	851	979	786	906	1035	*	*	*	*	*	*	*	*	*	*	*	*
	PGD	802	972	1164	852	1033	1227	*	*	*	*	*	*	*	*	*	*	*	*
28	PGA	256	265	198	264	274	196	318	326	222	330	338	*	371	380	*	361	370	*
	PGB	360	425	455	373	441	464	*	*	*	*	*	*	*	*	*	*	*	*
	PGC	711	819	953	741	854	988	*	*	*	*	*	*	*	*	*	*	*	*
	PGD	77	942	1145	809	981	1182	*	*	*	*	*	*	*	*	*	*	*	*
31.5	PGA	254	263	212	266	276	216	319	327	246	333	341	249	385	394	*	380	389	*
	PGB	354	418	463	372	440	480	*	*	*	*	*	*	*	*	*	*	*	*
	PGC	681	785	924	717	826	967	*	*	*	*	*	*	*	*	*	*	*	*
	PGD	747	906	1116	785	952	1165	*	*	*	*	*	*	*	*	*	*	*	*
35.5	PGA	246	255	221	264	274	232	317	325	268	334	342	276	394	404	273	394	404	*
	PGB	339	401	459	366	433	489	*	*	*	*	*	*	*	*	*	*	*	*
	PGC	629	725	863	685	789	935	*	*	*	*	*	*	*	*	*	*	*	*
	PGD	696	844	1052	756	916	1137	*	*	*	*	*	*	*	*	*	*	*	*
40	PGA	238	247	221	255	264	231	309	317	272	328	336	283	391	401	293	397	407	269
	PGB	327	387	449	349	412	474	*	*	*	*	*	*	*	*	*	*	*	*
	PGC	595	685	820	634	730	871	*	*	*	*	*	*	*	*	*	*	*	*
	PGD	659	799	1003	704	853	1066	*	*	*	*	*	*	*	*	*	*	*	*
45	PGA	237	246	224	245	254	227	308	316	276	318	326	280	384	393	297	392	402	278
	PGB	324	383	448	336	397	460	*	*	*	*	*	*	*	*	*	*	*	*
	PGC	582	670	804	598	689	823	*	*	*	*	*	*	*	*	*	*	*	*
	PGD	645	782	985	663	804	1009	*	*	*	*	*	*	*	*	*	*	*	*
50	PGA	239	248	242	250	259	250	312	320	304	324	332	313	400	410	360	400	410	344
	PGB	322	381	462	338	399	480	*	*	*	*	*	*	*	*	*	*	*	*
	PGC	568	655	797	582	671	815	*	*	*	*	*	*	*	*	*	*	*	*
	PGD	636	771	987	654	793	1012	*	*	*	*	*	*	*	*	*	*	*	*
56	PGA	232	240	243	249	258	260	304	311	310	324	332	329	391	401	379	411	421	387
	PGB	311	367	453	333	394	485	*	*	*	*	*	*	*	*	*	*	*	*
	PGC	533	614	752	573	660	808	*	*	*	*	*	*	*	*	*	*	*	*
	PGD	596	723	934	641	777	1001	*	*	*	*	*	*	*	*	*	*	*	*
63	PGA	222	230	241	241	250	262	288	295	307	316	324	336	384	393	397	403	413	411
	PGB	295	349	439	320	378	474	*	*	*	*	*	*	*	*	*	*	*	*
	PGC	492	567	700	535	616	760	*	*	*	*	*	*	*	*	*	*	*	*
	PGD	554	672	876	602	730	950	*	*	*	*	*	*	*	*	*	*	*	*
71	PGA	213	221	234	229	237	249	285	292	306	296	303	316	364	373	381	388	397	400
	PGB	283	334	422	302	357	450	*	*	*	*	*	*	*	*	*	*	*	*
	PGC	470	542	671	496	571	706	*	*	*	*	*	*	*	*	*	*	*	*
	PGD	531	644	841	558	676	881	*	*	*	*	*	*	*	*	*	*	*	*
80	PGA	206	213	227	220	228	241	270	277	292	292	299	315	349	358	369	368	377	384
	PGB	272	321	406	290	343	433	*	*	*	*	*	*	*	*	*	*	*	*
	PGC	444	512	635	474	546	676	*	*	*	*	*	*	*	*	*	*	*	*
	PGD	502	608	795	535	648	846	*	*	*	*	*	*	*	*	*	*	*	*
90	PGA	194	201	215	211	219	233	257	263	280	276	283	300	341	349	263	352	361	372
	PGB	256	302	384	278	329	417	*	*	*	*	*	*	*	*	*	*	*	*
	PGC	411	474	588	448	516	640	*	*	*	*	*	*	*	*	*	*	*	*
	PGD	465	564	738	507	614	803	*	*	*	*	*	*	*	*	*	*	*	*
100	PGA				201	208	226				266	272	294				348	356	379
	PGB				262	310	397				*	*	*				*	*	*
	PGC				415	478	595				*	*	*				*	*	*
	PGD				469	569	748				*	*	*				*	*	*
112	PGA																		
	PGB																		
	PGC																		
	PGD																		

* 敬请垂询
PGA (KW) 齿轮箱不带辅助冷却措施
PGB (KW) 齿轮箱带冷却风扇
PGC (KW) 齿轮箱带内置冷却盘管
PGD (KW) 齿轮箱带冷却风扇和内置冷却盘管

* On request
PGA (KW) Gear units without auxiliary cooling
PGB (KW) Gear units with fan
PGC (KW) Gear units with built-in cooling coil
PGD (KW) Gear units with fan and built-in cooling coil



齿轮箱

公称功率和输出扭矩

类型 P4

规格 7-16

Gear Units

Nominal Power Rating and output Torque

Type P4

Sizes 7-16

公称功率 P_{2N} (Kw)和公称输出扭矩 T_{2N} (KN.m)/Nominal power ratings P_{2N} (Kw) and output torque T_{2N} (KN.m)																										
iN	n1	n2	齿轮箱规格/Gear unit sizes (7-16)																							
			7		8		9		10		11		12		13		14		15		16					
			P_{2N}	T_{2N}	P_{2N}	T_{2N}	P_{2N}	T_{2N}	P_{2N}	T_{2N}	P_{2N}	T_{2N}	P_{2N}	T_{2N}	P_{2N}	T_{2N}	P_{2N}	T_{2N}	P_{2N}	T_{2N}	P_{2N}	T_{2N}				
100	1500	15	35.7	22.1			59	37.1			101	64.2			149	94.3			252	160						
	1000	10	23.1				39				67				99				168							
	750	7.5	17.3				29				50				74				126							
112	1500	13.4	31.5	22.5			53	37.1			90	64.0			133	94.3			225	159	254	181				
	1000	8.9	21				35				60				88				149					169		
	750	6.7	15.8				26				45				66				112					127		
125	1500	12	28.4	22.6	36		46	36.3	58		81	63.9	103		119	94.0	148		202	160	228	180				
	1000	8	18.9		23	27.6	30		39	46.4	54		63.9	68	81.5		79	94.0	99		118		134	160	151	
	750	6	14.2		17	23	29		40	51	59		74	101	113											
140	1500	10.7	25.2	22.5	32		41	36.5	51		72	63.2	91		106	94.1	132		180	159	203	180				
	1000	7.1	16.8		21	28.1	27		34	44.9	47		63.2	60	80.0		70	94.1	88		118		119	159	134	
	750	5.4	12.6		16	20	25		35	45	53		66	89	101											
160	1500	9.4	22.1	22.5	27		37	36.9	45		63	46.5	80		93	94.7	117		158	160	179	183				
	1000	6.3	14.7		18	27.3	24		30	46.5	42		64.2	54	81.8		62	94.7	78		119		105	160	120	
	750	4.7	11		13	18	23		32	40	46		58	79	90											
180	1500	8.3	17.6	20.2	22.5		30.4	33.7	37.2		52	42.1	66		76	89.3	96		129	150	147	170				
	1000	5.6	11.8		14.7	25.3	19.6		33.7	24.5	42.1		35	60.6	44		75.8	52	89.3		65		111	87	150	99
	750	4.2	8.8		11	14.7	18.4		26	33	39		49	65	74											
200	1500	7.5	16.7	20.6	20.6		27.4	33.7	33.3		47	43.1	60		70	88.0	86		118	150	132	168				
	1000	5	10.8		13.7	26.2	17.6		33.7	22.5	43.1		31	59.9	39		74.9	46	88.0		58		110	78	150	88
	750	3.8	8.1		10.3	13.2	16.9		24	29	35		43	59	66											
224	1500	6.7	14.7	21.0	18.6		24.5	33.5	30.4		42	41.9	53		62	88.0	77		105	151	119	170				
	1000	4.5	9.8		11.8	25.2	15.7		33.5	19.6	41.9		28	60.8	35		75.5	41	88.0		52		111	71	151	79
	750	3.3	7.4		8.8	11.8	14.7		21	26	31		39	53	60											
250	1500	6	12.7	21.1	16.7		21.6	32.8	26.5		37	42.1	48		55	86.6	69		94	150	106	168				
	1000	4	8.8		10.8	25.7	13.7		32.8	17.6	42.1		25	58.5	31		74.9	36	86.6		46		110	63	150	71
	750	3	6.6		8.1	10.3	13.2		18	24	27		35	47	53											
280	1500	5.4	11.4	20.6	14.3		19	33.0	22.8		32	40.6	42		48	86.4	60		82	145	92	165				
	1000	3.6	7.7		9.5	25.4	12.4		33.0	15.2	40.6		22	58.4	28		73.7	32	86.4		40		107	54	145	62
	750	2.7	5.8		7.1	9.3	11.4		16	21	24		30	41	46											
315	1500	4.8	9.5	20.6	12.4		16.2	31.4	20.9		29	40.0	37		43	85.7	53		72	146	82	163				
	1000	3.2	6.8		8.6	56.0	10.5		31.4	13.3	40.0		19	57.2	25		74.3	29	85.7		35		106	48	146	54
	750	2.4	5.1		6.5	7.8	10		14	19	21		26	36	41											
355	1500	4.2	8.2	18.4	10.5		14.3	32.2	18.1		26	38.6	32		37	83.7	47		58	132	72	161				
	1000	2.8	5.4		7.5	25.4	9.5		32.2	11.4	38.6		17	58.0	21		70.9	25	83.7		31		106	39	132	48
	750	2.1	4.1		5.6	7.1	8.6		13	16	19		24	31	36											
400	1500	3.8		25.8	9.5		16.2	39.9	16.2		29	39.9	29		29	72.6	42		59	105	39	149				
	1000	2.5			6.7		10.5		39.9	19	72.6		19	28	105		39									
	750	1.9			5.1		7.8		14	21	28		39													
450	1500	3.3		23.7	8.3		13.3	40.0	13.3		25	40.0	25		37	69.4	42		59	106	39	149				
	1000	2.2			5.5		9.3		40.0	16	69.4		16	25	106		39									
	750	1.7			4.1		7		12	19	25		39													



齿轮箱

公称功率和输出扭矩

类型 P4

规格 17-26

Gear Units

Nominal Power Rating and output Torque

Type P4

Sizes 17-26

公称功率 P_{2N} (Kw)和公称输出扭矩 T_{2N} (KN.m)/Nominal power ratings P_{2N} (Kw) and output torque T_{2N} (KN.m)

iN	n1	n2	齿轮箱规格/Gear unit sizes (17-26)																						
			17		18		19		20		21		22		23		24		25		26				
			P _{2N}	T _{2N}	P _{2N}	T _{2N}	P _{2N}	T _{2N}	P _{2N}	T _{2N}	P _{2N}	T _{2N}	P _{2N}	T _{2N}	P _{2N}	T _{2N}	P _{2N}	T _{2N}	P _{2N}	T _{2N}	P _{2N}	T _{2N}			
100	1500	15	330	210			495	315			692	440			923	588			1319	839					
	1000	10	219				330				461				615				615				879		
	750	7.5	165				247				346				461				461				659		
112	1500	13.4	294	209	353	250	441	313	508	361	618	439	692	492	824	585	943	669	1178	837	1325	941			
	1000	8.9	195		234		293		337		411		460		547		626		669		782		880		
	750	6.7	146		176		220		253		308		345		410		469		587		660				
125	1500	12	264	209	316	252	395	315	455	362	553	440	620	493	738	588	844	672	1055	840	1187	944			
	1000	8	175		211		264		303		369		413		492		563		672		704		791		
	750	6	132		158		198		228		276		309		369		422		528		593				
140	1500	10.7	235	208	281	250	353	313	405	359	494	438	552	490	658	584	753	667	941	834	1058	939			
	1000	7.1	155		187		234		269		328		366		437		499		624		702				
	750	5.4	117		140		176		202		246		275		328		374		468		527				
160	1500	9.4	206	210	248	253	310	316	356	364	434	444	485	497	579	592	660	677	826	846	929	951			
	1000	6.3	138		166		207		238		291		326		387		443		553		623				
	750	4.7	103		124		155		179		218		244		291		332		415		467				
180	1500	8.3	170	197	204	236	255	295	293	340	358	414	400	463	476	553	545	632	681	790	766	888			
	1000	5.6	115		137		172		198		241		270		321		368		460		516				
	750	4.2	86		103		129		148		181		202		241		276		345		387				
200	1500	7.5	154	195	184	234	230	294	265	337	322	410	362	460	430	548	492	627	615	782	692	882			
	1000	5	102		123		154		176		215		241		287		328		410		462				
	750	3.8	76		92		115		132		161		181		215		246		307		346				
224	1500	6.7	137	197	165	237	206	296	237	340	288	413	322	463	384	551	440	631	550	788	618	889			
	1000	4.5	92		111		138		159		193		217		258		295		368		416				
	750	3.3	69		83		104		119		145		162		193		221		276		312				
250	1500	6	123	194	147	234	184	292	212	337	258	409	289	459	344	548	394	627	492	784	554	880			
	1000	4	81		98		123		141		172		192		229		263		328		368				
	750	3	61		74		92		106		129		144		172		197		246		276				
280	1500	5.4	107	191	128	229	161	287	185	330	225	401	252	450	300	536	343	612	429	765	483	861			
	1000	3.6	71		86		107		124		150		168		200		229		286		322				
	750	2.7	53		64		81		93		113		126		150		172		214		242				
315	1500	4.8	95	191	114	229	143	286	164	329	200	400	224	449	267	534	305	612	382	766	429	860			
	1000	3.2	64		76		95		109		133		149		178		203		255		286				
	750	2.4	48		57		71		82		100		112		133		152		191		214				
355	1500	4.2	80	180	100	225	121	274	143	325	171	386	196	441	234	528	267	602	333	754	375	847			
	1000	2.8	53		67		81		96		114		130		156		178		222		250				
	750	2.1	40		50		61		72		86		98		117		133		167		187				
400	1500	3.8		210	84				126	316			176	439			241	606			340	853			
	1000	2.5			55				83				115				159				223				
	750	1.9			41				62				86				119				167				
450	1500	3.3																							
	1000	2.2																							
	750	1.7																							



齿轮箱
热功率
类型 P4
规格 7-26

Gear Units
Thermal Capacities
Type P4
Sizes 7-26

n1=750rpm

n1=750rpm

热功率PG (KW)/Thermal capacities PG (kW)

i _N		齿轮箱规格/Gear unit sizes (7-26)																				
		7	8	9	10	11	12	13	14	15	16	17	18	19	20	21	22	23	24	25	26	
100	PGA	40.7		56.8		84.2		112		150		168		236		323		*		*		
112	PGA	39.2		54.4		83.5		109		144		155	162	173	227	243	318	327	*	*	*	*
125	PGA	38.1	43.7	52.7	57.1	80.1	93.1	106	120	139	149	156	165	220	233	308	321	*	*	*	*	
140	PGA	36.1	41.9	51.0	54.6	77.5	92.4	103	117	135	143	150	160	212	225	292	321	*	*	*	*	
160	PGA	34.7	40.7	48.2	53.0	73.8	89.0	97.1	113	129	138	144	154	204	217	281	296	*	*	*	*	
180	PGA	33.1	38.7	46.1	51.3	71.2	85.7	93.4	110	127	133	141	148	194	209	277	281	*	*	*	*	
200	PGA	32.1	37.3	44.6	48.4	67.3	81.8	91.7	104	123	130	136	146	188	200	262	280	*	*	*	*	
224	PGA	30.3	35.7	42.9	46.3	64.5	78.8	87.5	99.9	115	127	127	141	180	192	250	264	*	*	*	*	
250	PGA	29	34.6	40.9	45.0	61.3	74.4	83.2	97.1	109	118	121	132	171	185	236	252	*	*	*	*	
280	PGA	28.1	32.4	39.7	43.2	58.9	71.6	80.6	92.6	106	112	118	124	164	176	227	238	*	*	*	*	
315	PGA	27.5	31.1	37.8	41.2	57.5	67.9	77.3	89.2	101	108	113	121	161	169	218	229	*	*	*	*	
355	PGA	26.2	30.2	37.2	40.0	54.7	65.3	73.7	85.8	99	101	110	116	153	165	207	220	*	*	*	*	
400	PGA		29.5		38.1		63.8	0.0	82.5		102		113		157		210		*		*	
450	PGA		28.1		37.5		60.6	0.0	78.6										*		*	

n1=1000rpm

n1=1000rpm

热功率PG (KW)/Thermal capacities PG (kW)

i _N		齿轮箱规格/Gear unit sizes (7-26)																			
		7	8	9	10	11	12	13	14	15	16	17	18	19	20	21	22	23	24	25	26
100	PGA	43.6		60.8		90.1		120		161		180		253		346		*		*	
112	PGA	42		58.2		89.4		117		154	166	173	185	243	260	340	350	*	*	*	*
125	PGA	40.8	46.8	56.4	61.1	85.8	99.7	114	128	149	160	167	177	235	249	330	344	*	*	*	*
140	PGA	38.7	44.9	54.6	58.5	83	98.9	110	125	144	153	161	171	227	241	313	344	*	*	*	*
160	PGA	37.2	43.6	51.6	56.7	79	95.3	104	121	138	148	154	165	218	232	301	317	*	*	*	*
180	PGA	35.8	41.4	49.1	54.9	76.2	91.8	100	118	136	142	151	158	208	224	297	304	*	*	*	*
200	PGA	34.4	39.9	47.8	51.8	72	87.6	98.2	111	132	139	146	156	201	214	280	300	*	*	*	*
224	PGA	32.1	38.2	45.9	49.6	69	84.4	93.7	107	123	136	136	151	193	206	268	283	*	*	*	*
250	PGA	31	37	43.8	48.2	65.6	79.7	89.1	104	117	126	130	141	183	198	253	270	*	*	*	*
280	PGA	30.1	34.7	42.5	46.2	63.1	76.7	86.3	99.1	113	120	126	133	176	188	243	255	*	*	*	*
315	PGA	29.4	33.3	40.5	44.1	58.6	72.7	82.8	95.5	108	116	121	130	172	181	233	245	*	*	*	*
355	PGA	28.1	32.3	39.8	42.8		69.9	78.9	91.9	106	111	118	124	164	177	222	236	*	*	*	*
400	PGA		31.6		40.8		68.3		88.3		109		121		168		225		*		*
450	PGA		30.1		40.1		61.9		84.2										*		*

n1=1500rpm

n1=1500rpm

热功率PG (KW)/Thermal capacities PG (kW)

i _N		齿轮箱规格/Gear unit sizes (7-26)																			
		7	8	9	10	11	12	13	14	15	16	17	18	19	20	21	22	23	24	25	26
100	PGA	48.7		67.6		99.1		130		172		190		264		348		*		*	
112	PGA	47.1		65.1		99.1		129		167	179	186	198	259	276	352	358	*	*	*	*
125	PGA	45.8	52.5	63.1	68.3	95.5	110	126	142	163	174	181	192	254	268	348	359	*	*	*	*
140	PGA	43.5	50.5	61.3	65.6	92.8	110	123	139	158	169	176	188	248	263	336	356	*	*	*	*
160	PGA	41.9	49.1	58	63.7	88.5	106	116	135	153	164	171	182	240	255	327	342	*	*	*	*
180	PGA	40.4	46.7	55.8	61.9	85.8	103	113	132	152	159	169	177	232	249	329	335	*	*	*	*
200	PGA	38.9	45.1	54	58.5	81.3	98.9	110	126	149	157	164	175	226	240	314	335	*	*	*	*
224	PGA	36.7	43.2	52	56.2	78.1	95.5	106	121	140	154	154	170	219	233	303	321	*	*	*	*
250	PGA	35.1	41.9	49.6	54.5	74.2	90.2	100	118	132	143	147	159	208	224	287	305	*	*	*	*
280	PGA	34	39.3	48.2	52.3	71.4	86.8	97.7	112	128	135	143	151	199	213	276	289	*	*	*	*
315	PGA	33.3	37.6	45.9	49.9	69.7	82.2	93.7	108	122	131	136	147	195	204	264	278	*	*	*	*
355	PGA	31.8	36.5	45.1	48.5	66.3	79.2	89.4	104	120	126	133	141	186	200	252	267	*	*	*	*
400	PGA		35.8		46.2		77.3		100		123		138		190		255		*		*
450	PGA		34		45.4		73.5		95.3										*		*

*敬请垂询

PGA (kW) 齿轮箱不带辅助冷却措施

*On request

PGA (kW) Gear units without auxiliary cooling



齿轮箱
 公称功率和输出扭矩
 类型V2
 规格4-18

Gear Units
 Nominal Power Rating and output Torque
 Type V2
 Size 4-18

公称功率P2N(kW)和公称输出扭矩T2N(kN. m)/Nominal power ratings P2N(kW) and output torque T2N(kN. m)																																
i _N	n1	n2	齿轮箱规格/Gear unit sizes (4-18)																													
			4		5		6		7		8		9		10		11		12		13		14		15		16		17		18	
			P _{2N}	T _{2N}	P _{2N}	T _{2N}	P _{2N}	T _{2N}	P _{2N}	T _{2N}	P _{2N}	T _{2N}	P _{2N}	T _{2N}	P _{2N}	T _{2N}	P _{2N}	T _{2N}	P _{2N}	T _{2N}	P _{2N}	T _{2N}	P _{2N}	T _{2N}	P _{2N}	T _{2N}	P _{2N}	T _{2N}	P _{2N}	T _{2N}		
5	1500	300	201		310				626				986			1517			2262			4024										
	1000	200	133	6.4	206	9.8			417	20			657	31		1011	48		1508	72.0		2682	128									
	750	150	100		154				313				493			758			1131			2011										
5.6	1500	268	182		278				560				881			1416			2051			3594			3977							
	1000	179	122	6.5	185	9.9			374	20			588	31		946	51		1369	73.2		2400	13		2657	14.2	3837	205				
	750	134	91		139				280				141			710			1027			1800			1992		2878					
6.3	1500	238	162		246		314		497		623		782		994		1314		1538		1931		2229		3401		3689		5102			
	1000	159	108	6.5	164	9.9	209	13	332	20	416	25.0	522	31	664	40	877	53	1027	62	1289	77.6	1489	90	2272	137	2464	148	3408	205		
	750	119	81		123		157		249		312		391		498		658		770		967		1117		1704		1848		2556			
7.1	1500	211	133		203		260		411		515		647		822		1134		1318		1642		1889		2858		3139		4222			
	1000	141	89	135	135	9.2	173	12	274	19	432	23.3	432	29	550	37	758	51	881	60	1098	74.4	1262	86	1909	129	2097	1142	2821	191	3327	226
	750	106	67		101		130		206		324		324		412		568		661		823		947		1432		1573		2116		2945	
8	1500	188	120		181		231		367		459		576		733		1042		1217		1543		1765		2546		2855		3761		4436	
	1000	125	79	101	121		154	12	243	19	305	23.3	383	29	487	37	692	53	809	62	1026	78.4	1173	90	1692	129	1898	145	2501	191	2950	225
	750	94	60		90		115		182		229		287		365		519		606		770		880		1269		1424		1876		2212	
9	1500	167	106		161		205		325		408		512		651		925		1117		1390		1621		2262		2536		3341		3941	
	1000	111	71	6.1	107		136	12	216	19	270	23.2	340	29	432	37	614	53	742	64	923	79.3	1077	93	1503	129	1686	145	2221	191	2620	225
	750	83	53		80		102		162		203		255		324		461		556		692		808		1127		1261		1666		1963	
10	1500	150	95		144		184		292		366		460		584		831		1020		1248		1520		2032		2278		3001		3540	
	1000	100	63	6.0	96		123	12	194	19	244	23.3	307	29	389	37	554	53	680	65.0	832	79.5	1013	97	1554	129	1518	145	2000	191	2360	225
	750	75	47		72		92		146		183		230		292		415		510		624		760		1016		1139		1500		1770	
11	1500	134	82		124		160		253		316		398		506		719		884		1080		1351		1759		1972		2599		3066	
	1000	89	54	5.8	83		105	11	168	19	210	28.2	264	28	336	36.0	478	51	586	63	717	76.7	897	96	1169	125	1310	140	1726	185	2036	218
	750	67	41		62		79		126		157		198		252		358		440		538		673		876		983		1295		1527	
13	1500	120					143				284				453				791				1210				1766				2746	
	1000	80					95	11			189				302	36			527	63			807	96			1177	141			1830	218
	750	60					71				142				227				395				605				883				1372	
14	1500	107					127				253				404				705				1079									
	1000	71					85	11			167				268	36			467	63			715	96								
	750	54					63				125				201				351				537									

采取强制润滑

Forced lubrication required



齿轮箱

Gear Units

热功率

Thermal Capacities

类型 V2

Type V2

规格 4-11

Sizes 4-11

热功率 P_G (Kw)/Thermal capacities P_G (Kw)

齿轮箱规格/Gear unit sizes (4-11)

i_N	n1	齿轮箱规格/Gear unit sizes (4-11)																							
		4			5			6			7			8			9			10			11		
		750	1000	1500	750	1000	1500	750	1000	1500	750	1000	1500	750	1000	1500	750	1000	1500	750	1000	1500	750	1000	1500
5	P_{GA}	47.1	48.3	35.3	57.2	58.6	*				85.3	77.4	*				95.9	87.1	*				*	*	*
	P_{GB}	94.7	113	139	130	155	184				203	246	283				245	297	328				402	487	478
	P_{GC}	119	137	159	178	206	238				280	319	368				349	398	459				593	677	774
	P_{GD}	161	194	249	241	291	366				382	468	581				472	578	705				804	984	1144
5.6	P_{GA}	46.6	47.7	38.6	58.4	59.8	*				86.2	78.3	*				99.4	90.2	*				132	120	*
	P_{GB}	91.3	109	135	128	153	185				192	232	274				233	282	322				397	481	504
	P_{GC}	114	132	154	172	199	231				257	293	340				322	367	424				563	643	738
	P_{GD}	155	187	241	233	282	359				353	432	543				437	535	662				770	943	1126
6.3	P_{GA}	45.9	47	40	57.3	58.7	*	66.7	68.3	*	83.5	75.8	*	99.0	89.9	*	98.5	89.4	*	108	98.3	*	134	122	*
	P_{GB}	88.0	105	132	121	145	178	142	170	206	178	216	259	216	261	308	219	265	310	248	300	345	364	441	479
	P_{GC}	109	126	147	160	185	215	228	264	306	233	266	308	340	388	449	292	333	385	403	460	531	496	566	651
	P_{GD}	148	179	231	218	263	336	297	359	456	321	393	497	448	548	690	399	489	612	525	643	799	681	834	1010
7.1	P_{GA}	43.9	45	40.6	55.8	57.2	44	67.3	69	50.6	81.8	74.3	*	97.9	88.9	*	98.1	89.1	*	109	99.3	*	145	132	*
	P_{GB}	82.9	99	125	115	137	169	139	166	204	168	203	248	203	246	298	207	250	299	235	284	336	360	436	493
	P_{GC}	100	116	135	148	171	199	222	257	298	214	244	284	313	357	414	268	306	354	370	422	488	478	545	629
	P_{GD}	136	164	213	201	243	313	289	349	447	296	362	462	413	506	642	368	451	570	485	594	747	660	808	996
8	P_{GA}	41.8	42.8	39.9	53.5	54.8	45.1	65.6	67.2	53.4	79.4	72.1	53	94.8	86.1	*	96.3	87.4	*	108	97.7	*	142	129	*
	P_{GB}	77.8	92.9	117	107	128	160	132	157	195	159	192	236	189	229	280	196	237	287	221	267	321	330	400	463
	P_{GC}	93	107	124	136	157	182	205	237	276	198	226	263	283	323	375	248	283	328	336	383	444	422	482	557
	P_{GD}	126	152	198	186	225	290	268	324	417	274	336	430	375	459	586	342	419	533	442	541	686	587	719	896
9	P_{GA}	40.0	41	39.3	51.4	52.7	45.7	62.9	64.5	54.4	77.3	70.2	55.8	91.1	82.7	61.6	94.5	85.8	59.6	105	95.3	*	142	129	*
	P_{GB}	73.6	87.8	111	101	121	153	124	148	186	150	182	226	178	215	266	187	226	277	207	251	306	316	383	452
	P_{GC}	86	98.8	115	125	144	168	189	218	253	186	212	246	260	297	346	234	267	310	308	352	409	398	454	526
	P_{GD}	117	141	183	170	206	267	247	299	386	258	316	407	346	424	543	323	396	507	408	500	637	555	679	853
10	P_{GA}	31.9	34.6	33.7	45.5	49.3	44	56.3	61.1	53.3	64.8	66.4	55.1	77.3	79.2	62.3	80.0	81.9	60.8	89.5	91.7	63.9	122	125	*
	P_{GB}	61.0	72.8	92.8	93	111	140	116	138	174	140	169	211	167	202	251	175	212	261	196	237	291	297	359	429
	P_{GC}	68	78.9	91.9	112	129	150	173	200	233	168	192	224	240	274	318	214	244	284	285	325	377	365	417	483
	P_{GD}	93	112	147	153	185	240	228	276	356	235	288	372	320	392	505	296	363	465	377	462	591	511	626	791
11	P_{GA}	30.9	33.5	33	40.9	44.4	40.4	53.9	58.4	52.1	58.4	59.8	51	74.3	76.1	61.9	72.7	74.5	57.7	86.9	89	65.2	111	114	*
	P_{GB}	58.9	70.3	89.8	83	99.5	125	110	131	165	124	150	188	159	192	240	154	187	232	187	226	279	263	318	382
	P_{GC}	65	75.4	87.9	98	113	131	158	183	213	147	168	195	225	257	298	186	212	246	269	307	356	316	361	418
	P_{GD}	89	107	140	134	162	210	209	252	327	206	252	326	301	368	474	258	316	406	358	438	561	443	543	688
13	P_{GA}							50.3	54.5	50.1				70.5	72.2	61.7				83.1	85.1	66.9			
	P_{GB}							100	119	151				148	179	224				175	212	264			
	P_{GC}							141	163	189				205	234	272				245	280	326			
	P_{GD}							186	225	292				275	337	435				327	401	515			
14	P_{GA}							45.2	49	46				63.6	65.2	57.4				75.2	77	63.1			
	P_{GB}							89	106	135				131	159	200				156	189	236			
	P_{GC}							123	142	166				180	205	238				213	243	283			
	P_{GD}							162	196	255				239	293	380				284	348	449			

* 敬请垂询

* On request

P_{GA} (KW) 齿轮箱不带辅助冷却措施

P_{GA} (KW) Gear units without auxiliary cooling

P_{GB} (KW) 齿轮箱带冷却风扇

P_{GB} (KW) Gear units with fan

P_{GC} (KW) 齿轮箱带内置冷却盘管

P_{GC} (KW) Gear units with built-in cooling coil

P_{GD} (KW) 齿轮箱带冷却风扇和内置冷却盘管

P_{GD} (KW) Gear units with fan and built-in cooling coil

齿轮箱

Gear Units

热功率

Thermal Capacities

类型 V2

Type V2

规格 12-18

Sizes 12-18

热功率 P_G (Kw)/Thermal capacities P_G (Kw)																						
i_N	n1	齿轮箱规格/Gear unit sizes (12-18)																				
		12			13			14			15			16			17			18		
		750	1000	1500	750	1000	1500	750	1000	1500	750	1000	1500	750	1000	1500	750	1000	1500	750	1000	1500
5	P_{GA}				*	*	*				*	*	*									
	P_{GB}				579	684	574				667	788	486									
	P_{GC}				1178	1344	1524				1642	1821	2040									
	P_{GD}				1516	1838	2019				1966	2383	2386									
5.6	P_{GA}				*	*	*				*	*	*				*	*	*			
	P_{GB}				582	688	646				680	804	618				727	859	565			
	P_{GC}				1163	1289	1470				1590	1763	1992				1874	2055	2307			
	P_{GD}				1476	1789	2044				1925	2333	2489				2218	2689	2739			
6.3	P_{GA}	156	142	*	*	*	*	*	*	*	*	*	*	*	*	*	*	*	*	*	*	*
	P_{GB}	459	556	581	539	637	633	652	771	753	659	779	664	709	838	684	719	850	646			
	P_{GC}	855	976	1120	992	1132	1295	1273	1411	1613	1467	1627	1847	1607	1782	2019	1741	1909	2155			
	P_{GD}	1094	1340	1596	1299	1574	1839	1612	1954	2267	1789	2168	2393	1952	2366	2574	2087	2530	2689			
7.1	P_{GA}	174	158	*	172	151	*	200	176	*	*	*	*	*	*	*	*	*	*	*	*	*
	P_{GB}	451	546	601	539	637	676	650	768	804	640	756	720	690	815	754	709	838	740	759	897	760
	P_{GC}	816	931	1072	961	1097	1261	1219	1352	1552	1360	1508	1722	1484	1645	1875	1629	1787	2031	1750	1919	2177
	P_{GD}	1044	1278	1556	1271	1541	1848	1563	1895	2261	1673	2028	2331	1818	2204	2505	1968	2386	2666	2110	2558	2817
8	P_{GA}	171	155	*	175	154	*	206	181	*	*	*	*	*	*	*	*	*	*	*	*	*
	P_{GB}	411	498	564	498	588	646	597	705	768	597	705	713	663	784	775	671	793	756	740	874	808
	P_{GC}	716	817	942	882	978	1126	1069	1185	1364	1223	1356	1553	1381	1531	1751	1478	1621	1851	1635	1793	2043
	P_{GD}	922	1129	1392	1134	1375	1674	1372	1663	2016	1510	1830	2152	1699	2059	2400	1794	2174	2499	1982	2402	2729
9	P_{GA}	178	162	*	181	159	*	220	193	*	192	169	*	200	176	*	*	*	*	*	*	*
	P_{GB}	405	490	568	478	565	640	591	699	785	579	684	724	618	730	759	655	774	782	696	823	812
	P_{GC}	693	791	915	801	914	1055	1039	1152	1329	1157	1283	1474	1234	1368	1570	1406	1542	1766	1481	1624	1858
	P_{GD}	893	1094	1363	1069	1296	1598	1341	1625	1996	1436	1741	2085	1529	1853	2204	1714	2078	2444	1805	2188	2549
10	P_{GA}	149	153	*	159	157	*	190	188	*	174	172	*	184	182	*	177	175	*	*	*	*
	P_{GB}	369	447	525	453	535	616	543	642	734	544	643	698	596	704	753	624	737	770	676	799	818
	P_{GC}	613	700	810	741	846	978	918	1018	1176	1055	1170	1347	1169	1296	1490	1305	1431	1642	1410	1546	1772
	P_{GD}	794	972	1218	990	1200	1490	1191	1444	1787	1317	1596	1933	1452	1760	2118	1596	1935	2306	1720	2085	2464
11.2	P_{GA}	146	150	*	147	145	*	187	185	*	164	162	*	183	181	*	171	169	*	189	187	*
	P_{GB}	352	426	506	403	476	555	519	613	709	492	581	641	560	662	721	566	669	714	643	760	797
	P_{GC}	577	659	764	643	734	849	859	952	1101	929	1030	1186	1066	1182	1360	1155	1267	1457	1312	1439	1652
	P_{GD}	750	918	1156	863	1046	1306	1119	1356	1688	1164	1411	1722	1333	1616	1960	1419	1720	2068	1601	1940	2315
12.5	P_{GA}	142	145	*				185	183	*				177	175	*				188	186	*
	P_{GB}	330	400	481				490	579	681				506	598	669				585	691	749
	P_{GC}	529	604	701				796	882	1021				937	1039	1198				1163	1276	1468
	P_{GD}	690	845	1070				1035	1255	1574				1180	1430	1754				1427	1730	2093
14	P_{GA}	128	131	*				170	168	*												
	P_{GB}	292	353	428				435	514	611												
	P_{GC}	457	522	605				688	763	884												
	P_{GD}	599	733	931				901	1092	1377												

* 敬请垂询

 P_{GA} (KW) 齿轮箱不带辅助冷却措施

 P_{GB} (KW) 齿轮箱带冷却风扇

 P_{GC} (KW) 齿轮箱带内置冷却盘管

 P_{GD} (KW) 齿轮箱带冷却风扇和内置冷却盘管

* On request

 P_{GA} (KW) Gear units without auxiliary cooling

 P_{GB} (KW) Gear units with fan

 P_{GC} (KW) Gear units with built-in cooling coil

 P_{GD} (KW) Gear units with fan and built-in cooling coil



齿轮箱
公称功率和输出扭矩
类型V3
规格4-11

Gear Units
Nominal Power Rating and output torque
Type v3
Sizes 4-11

公称功率P2N(KW) 和公称输出扭矩t2n(kn.m) /nominal power ratings p2n(kw) and output torque t2n(kn.m)																		
in	n1	n2	齿轮箱规格/gear unit sizes (4-11)															
			4		5		6		7		8		9		10		11	
			P2n	T2n	P2n	T2n	P2n	T2n	P2n	T2n	P2n	T2n	P2n	T2n	P2n	T2n	P2n	T2n
12.5	1500	120	72		124				224				369				691	
	1000	80	48		82				149				246				460	
	750	60	36	5.8	61	9.8			112	17.8			184	29.3			345	
14	1500	107	70		114				213				347				667	
	1000	71	46		76				142				230				442	
	750	54	35	6.2	57	10.1			106	19.0			172	30.7			332	
16	1500	94	67		108		124		204		222		320		368		618	
	1000	63	45		72		83		137		148		214		246		415	
	750	47	34	6.9	54	11.1	62	12.7	102	20.9	111	22.6	161	32.7	184	37.5	311	
18	1500	83	61		103		114		192		210		309		341		565	
	1000	56	41		69		77		129		142		208		230		381	
	750	42	31	7.0	52	11.9	57	13.2	97	22.2	106	24.4	156	35.7	172	39.5	286	
20	1500	75	55		96		108		179		206		294		323		523	
	1000	50	37		63		72		119		137		195		215		349	
	750	38	28	7.0	47	12	54	13.8	89	22.7	102	26.1	146	37.3	161	41.1	261	
22.4	1500	67	49		85		104		160		194		263		308		467	
	1000	45	33		57		69		107		130		176		206		314	
	750	33	24	7.0	43	12.1	52	14.8	80	22.9	98	27.9	132	37.7	154	44	235	
25	1500	60	41		71		95		133		167		220		270		390	
	1000	40	27		47		63		88		111		146		179		260	
	750	30	21	6.6	35	11.2	47	15	66	21.1	83	26.4	110	34.9	135	42.8	195	
28	1500	54	36		64		85		120		150		197		242		352	
	1000	36	25		42		57		79		100		131		162		234	
	750	27	18	6.6	32	11.3	43	15.2	60	21.2	75	26.7	98	35.1	121	43.2	176	
31.5	1500	48	32		57		75		107		133		175		216		313	
	1000	32	22		37		50		71		89		117		143		208	
	750	24	16	6.5	28	11.2	37	15	53	21.2	67	26.8	87	35.1	107	43	156	
35.5	1500	42	28		50		67		93		117		154		188		273	
	1000	28	19		33		44		62		77		102		125		182	
	750	21	14	6.3	25	11.3	33	15	46	20.9	58	26.2	76	34.6	94	42.5	137	
40	1500	38	25		45		60		84		106		139		171		247	
	1000	25	17		29		39		55		70		91		112		163	
	750	18.8	12	6.4	22	11.2	29	15	41	21.0	52	26.6	68	34.8	84	42.7	122	
45	1500	33	23		39		52		73		91		121		148		215	
	1000	22	15		25		34		48		61		80		98		143	
	750	16.7	11	6.3	19	11	26	14.7	36	20.6	46	26.1	60	34.5	74	42.1	107	
50	1500	30	20		34		46		65		81		106		130		189	
	1000	20	13		23		30		43		53		70		86		125	
	750	15	10	6.4	17	10.9	23	14.5	32	20.4	40	25.4	53	33.6	65	41.3	94	
56	1500	27	17		30		41		58		72		95		117		170	
	1000	17.9	11		20		28		38		48		63		78		113	
	750	13.4	8.6	6.1	15	10.7	21	14.7	29	20.3	36	25.4	47	33.5	58	41.7	85	
63	1500	24	15		27		36		50		65		85		105		151	
	1000	15.9	10		17		24		33		43		56		68		100	
	750	11.9	7.1	5.7	13	10.3	18	14.3	25	20.0	32	25.7	42	33.7	51	41.2	75	
71	1500	21	13		23		32		41		56		70		91		124	
	1000	14.1	9		15		21		28		38		48		61		84	
	750	10.6	6.9	6.2	11	10.3	16	14.2	21	18.7	29	25.8	36	32.2	46	41.2	63	
80	1500	18.8					26				49				82			
	1000	12.5					17				33				54			
	750	9.4					13	13.1			25	25.4			41	41.4		
90	1500	16.7					23				42				71			
	1000	11.1					15				28				47			
	750	8.3					11	13.1			21	23.7			35	40		



齿轮箱

公称功率和输出扭矩

类型V3

规格4-11

Gear Units

Nominal Power Rating and output torque

Type v3

Sizes 12-19

公称功率P2N(KW) 和公称输出扭矩T2n(kn.m) /nominal power ratings p2n(kw) and output torque T2n(kn.m)																		
in	n1	n2	齿轮箱规格/gear unit sizes (4-11)															
			12		13		14		15		16		17		18		19	
			P2n	T2n	P2n	T2n	P2n	T2n	P2n	T2n	P2n	T2n	P2n	T2n	P2n	T2n	P2n	T2n
12.5	1500	120			1048				1741				2573				3298	
	1000	80			698				1160				1715				2199	
	750	60			524	83.4			870	139			1286	205			1649	262
14	1500	107			960				1611			1741		2293		2705	3082	
	1000	71			636				1069			1155		1521		1794	2044	
	750	54			477	85.1			802	143.0		1141	154	1141	203	1346	240	1533
16	1500	94	685		865		1072		1467			1591		2066		2376	2841	
	1000	63	459		580		688		983			1066		1385		1593	1905	
	750	47	344	70.1	435	88.6	516	105	737	150.0		799	163	1039	212	1195	243	1429
18	1500	83	634		791		930		1350			1460		1825		2189	2628	
	1000	56	427		533		628		910			985		1231		1477	1772	
	750	42	321	73.5	400	91.7	471	108	683	156.0		739	169	923	212	1108	254	1329
20	1500	75	599		748		865		1261			1377		1649		1978	2474	
	1000	50	399		498		576		841			918		1099		1319	1649	
	750	38	695	76.2	373	95.1	432	110	631	161.0		688	175	825	210	989	252	1236
22.4	1500	67	557		668		795		1127			1274		1473		1767	2209	
	1000	45	374		448		533		756			856		989		1187	1484	
	750	33	280	80.0	336	95.9	400	114	567	162.0		642	183	742	212	890	254	1113
25	1500	60	475		558		695		942			1064		1231		1477	1846	
	1000	40	317		371		464		627			710		820		985	1231	
	750	30	237	75.6	279	88.7	348	111	470	150.0		532	169	615	196	739	235	923
28	1500	54	417		502		625		848			958		1107		1330	1662	
	1000	36	285		334		417		564			639		738		886	1107	
	750	27	214	76.3	251	89.4	312	111	423	151.0		479	171	553	197	664	237	831
31.5	1500	48	380		446		556		754			852		985		1182	1477	
	1000	32	253		297		370		502			567		657		788	985	
	750	24	190	76.1	223	89.3	278	111	376	151.0		426	171	492	198	591	237	739
35.5	1500	42	332		390		486		659			745		861		1034	1293	
	1000	28	221		260		324		439			497		574		689	861	
	750	21	166	75.1	195	88	243	110	329	149.0		373	168	431	195	517	234	646
40	1500	38	301		353		440		596			674		779		935	1169	
	1000	25	198		232		289		392			443		513		615	769	
	750	18.8	148	75.6	174	88.7	217	110	294	150.0		332	169	384	196	462	235	577
45	1500	33	261		307		382		517			585		677		812	1015	
	1000	22	173		204		255		345			390		451		541	677	
	750	16.7	130	74.5	153	87.6	191	110	259	148.0		293	168	338	194	406	232	508
50	1500	30	230		270		336		456			516		597		715	895	
	1000	20	153		180		224		304			344		397		477	597	
	750	15	115	73.0	135	85.7	168	107	228	145.0		258	164	298	190	358	228	447
56	1500	27	207		243		303		410			465		537		644	806	
	1000	17.9	137		162		200		272			308		355		427	534	
	750	13.4	103	73.2	121	86.4	150	107	204	145.0		231	165	266	190	320	228	400
63	1500	24	184		216		269		365			412		477		573	715	
	1000	15.9	122		143		179		241			274		315		379	474	
	750	11.9	91	73.2	108	86.3	134	107	181	145.0		205	165	237	190	284	228	356
71	1500	21	161		189		236		319			361		417		501	626	
	1000	14.1	107		126		158		214			242		280		336	420	
	750	10.6	81	72.8	95	85.7	118	107	160	145.0		182	164	210	190	252	228	315
80	1500	18.8	143				211					323				448		
	1000	12.5	96				140					215				298		
	750	9.4	72	73.3			105	107				161	164			224	228	
90	1500	16.7	124				187											
	1000	11.1	83				124											
	750	8.3	62	71.0			93	107										



齿轮箱

公称功率和输出扭矩

类型V3

规格4-11

Gear Units

Nominal Power Rating and output torque

Type v3

Sizes 20-26

公称功率P2N(KW) 和公称输出扭矩T2n(kn.m) /nominal power ratings p2n(kw) and output torque T2n(kn.m)																
in	n1	n2	齿轮箱规格/gear unit sizes (4-11)													
			20		21		22		23		24		25		26	
			P2n	T2n	P2n	T2n	P2n	T2n	P2n	T2n	P2n	T2n	P2n	T2n	P2n	T2n
12.5	1500	120				4489										
	1000	80				2990										
	750	60				2243	357									
14	1500	107	3470			4235			4764							
	1000	71	2303			2810			3161							
	750	54	1727	308		2107	376		2370	423						
16	1500	94	3183			3927			4361							
	1000	63	2133			2631			2922							
	750	47	1599	326		1973	402		2192	447						
18	1500	83	2920			3650			3996							
	1000	56	1970			2462			2696							
	750	42	1477	339.0		1847	423		2022	464						
20	1500	75	2737			3463			3752		4617					
	1000	50	1825			2308			2501		3078			4397		
	750	38	1369	349.0		1731	441		1876	478	2308	588.0		3298	840	
22.4	1500	67	2541			3093			3462		4124		4715			
	1000	45	1706			2078			2325		2770		3166		3957	4452
	750	33	1280	365.0		1558	445		1744	497	2077	593.0	2374	677	2968	847
25	1500	60	2124			2585			2893		3448		3940			
	1000	40	1416			1724			1929		2298		2626		3283	3694
	750	30	1062	338.0		1293	412		1446	460	1724	549.0	1970	627	2462	784
28	1500	54	1911			2327			2604		3103		3546		4433	
	1000	36	1274			1551			1736		2068		2364		2955	3324
	750	27	956	341.0		1164	415		1302	464	1551	553.0	1773	632	2216	790
31.5	1500	48	1699			2068			2315		2758		3152		3940	4433
	1000	32	1133			1379			1543		1838		2101		2626	2955
	750	24	850	341.0		1034	415		1157	464	1379	553.0	1576	632	1970	790
35.5	1500	42	1487			1810			2026		2413		2758		3448	3879
	1000	28	991			1206			1350		1608		1838		2298	2585
	750	21	743	336.0		905	409		1013	458	1206	545.0	1379	623	1724	779
40	1500	38	1345			1638			1833		2183		2495		3119	3509
	1000	25	885			1077			1205		1436		1642		2052	2309
	750	18.8	664	338.0		808	411		904	460	1077	548.0	1231	627	1539	784
45	1500	33	1168			1422			1592		1896		2167		2709	3047
	1000	22	778			948			1060		1264		1145		1805	2032
	750	16.7	584	334.0		711	407		795	456	948	543.0	1083	621	1354	776
50	1500	30	1029			1253			1402		1671		1910		2387	2683
	1000	20	686			835			935		1113		1273		1591	1790
	750	15	514	328.0		626	399		701	446	835	532.0	955	608	1193	760
56	1500	27	926			1128			1262		1504		1719		2148	2417
	1000	17.9	614			748			836		997		1139		1424	1602
	750	13.4	460	328.0		561	400		627	447	747	533.0	854	609	1068	762
63	1500	24	824			1002			1122		1337		1528		1910	2148
	1000	15.9	545			664			743		885		1012		1264	1423
	750	11.9	409	328.0		498	400		557	447	664	533.0	759	609	948	761
71	1500	21	720			877			981		1169		1337		1671	1880
	1000	14.1	484			589			658		785		897		1122	1262
	750	10.6	363	328.0		442	399		494	464	589	532.0	673	608	841	761
80	1500	18.8	645						897				1196			1682
	1000	12.5	428						584				795			1119
	750	9.4	321	327.0					438	446			596	607		839
90	1500	16.7														
	1000	11.1														
	750	8.3														

齿轮箱
热功率
类型 V3
规格 4-9

Gear Units
Thermal capacities
type v3
sizes 4-9

热功率 PG(KW)/ Thermal capacities PG (KW)

IN	n1	齿轮箱规格/gear unit sizes (4-9)																	
		4			5			6			7			8			9		
		750	1000	1500	750	1000	1500	750	1000	1500	750	1000	1500	750	1000	1500	750	1000	1500
12.5	PGA	35.1	38.1	39.4	46.8	50.8	50.4				74.3	79.7	76.7				96.1	103	95.4
	PGB	55.5	66.3	84.8	78.7	93.9	118				124	150	186				169	204	250
	PGC	66.7	76.8	94.7	108	124	151				189	218	265				280	323	390
	PGD	82.8	100	131	133	161	209				229	280	362				337	413	529
14	PGA	34.2	37.1	38.6	45.6	49.4	49.6				72.2	77.4	75.7				94.2	101	95.2
	PGB	54	64.4	82.6	76.2	90.9	114				119	144	180				164	198	244
	PGC	64.7	74.5	91.9	103	119	146				182	210	257				272	313	380
	PGD	80.4	97.2	127	128	155	202				221	270	350				326	399	514
16	PGA	32.5	35.2	36.8	44.2	47.9	48.3	51.1	55.4	55.4	69	74	72.9	80.4	86.2	83.3	92.7	99.4	94.3
	PGB	51.4	61.3	78.6	73.3	87.5	110	83.8	100	126	113	137	172	131	158	196	159	193	239
	PGC	61.4	70.8	87.4	99.8	115	141	111	129	157	174	200	244	19.4	223	272	264	304	369
	PGD	76.3	92.2	121	123	149	195	137	165	216	210	257	334	233	285	369	317	388	500
18	PGA	31.6	34.3	35.9	42.9	46.5	47.2	49.5	53.7	54.1	66.9	71.7	71.1	77.6	83.2	81.1	90	96.5	92.5
	PGB	49.9	59.5	76.4	71	84.8	107	81.4	97.1	122	110	133	167	126	153	191	154	187	232
	PGC	59.5	68.5	84.7	96.3	111	136	106	122	150	167	192	235	188	217	265	254	293	357
	PGD	74.1	89.5	117	119	144	189	132	159	208	202	247	322	226	277	359	306	375	485
20	PGA	29.9	32.4	34	41.1	44.6	45.6	47.9	51.9	52.6	64.3	68.9	68.8	74	79.4	78	86.5	92.8	89.8
	PGB	47	56.1	72.1	68.1	81.3	103	78.3	93.5	118	105	127	161	120	145	182	148	179	223
	PGC	56.2	64.8	80.1	92.9	107	131	102	118	145	160	184	225	177	204	249	243	280	342
	PGD	69.8	84.3	111	114	138	181	127	154	201	193	236	307	213	261	340	294	360	466
22.4	PGA	29.1	31.6	33.3	40.6	44	45.1	46.5	50.4	51.4	62.3	66.8	67.2	72.2	77.4	76.7	84.6	90.7	88.6
	PGB	45.7	54.6	70.3	67	80	101	76	90.7	115	102	123	155	116	141	177	145	175	218
	PGC	54.7	63	77.9	91.1	105	130	100	115	142	154	178	218	172	198	242	236	272	332
	PGD	68	82.2	108	113	137	180	123	149	195	185	226	296	207	253	330	284	348	452
25	PGA	27.8	30.1	31.9	38.5	41.8	43.3	44.8	48.6	50.1	60.6	65	66.2	69.7	74.7	75.2	81.4	87.3	86.9
	PGB	43.3	51.7	66.7	63.3	75.5	96.6	72.8	86.9	110	98.3	119	151	111	134	170	137	166	209
	PGC	51.6	59.4	73.6	86.3	99.4	122	95.5	110	135	147	169	208	164	189	232	220	253	310
	PGD	64.1	77.4	102	106	128	168	118	142	186	177	217	284	198	243	317	265	324	422
28	PGA	26.7	29	30.9	37.4	40.6	42.5	44.3	48	50	57.9	62.1	64.1	67.8	72.7	74.4	78.2	83.9	85
	PGB	41.4	49.4	63.9	60.9	70.7	93.3	71.6	85.5	109	92.5	112	143	107	130	165	130	157	199
	PGC	48.6	56	69.4	81.6	94	116	94.6	109	134	135	156	193	159	183	225	204	235	288
	PGD	60.5	73.1	96.7	100	121	159	117	141	185	164	201	264	191	234	306	247	302	395
31.5	PGA	25.4	27.5	29.4	35.6	38.6	40.7	42	45.5	47.8	55.2	59.2	61.7	65.6	70.3	72.7	75.2	80.6	82.7
	PGB	39.2	46.8	60.7	57.6	68.7	88.5	67.5	80.6	103	87.6	106	136	103	125	160	123	149	190
	PGC	45.6	52.5	65.2	76	87.6	108	88.5	102	126	127	146	180	151	174	215	191	220	271
	PGD	56.8	68.6	90.8	93.5	113	149	110	133	175	154	188	247	181	222	292	230	282	370
35.5	PGA	23.9	25.9	27.8	33.6	36.4	38.6	40.6	44	46.4	52.6	56.4	59.1	62.5	67	69.8	71.7	76.9	79.6
	PGB	36.7	43.8	56.8	53.9	64.3	83	64.9	77.5	99.8	82.6	100	129	98.3	119	152	116	141	181
	PGC	41.9	48.3	59.9	69.6	80.2	99.3	84	96.8	119	117	135	167	141	162	200	174	201	248
	PGD	52.2	63.1	83.7	86.1	104	138	104	126	166	142	174	229	169	207	272	212	260	341
40	PGA	20.8	22.6	24.3	29.2	31.7	33.7	38.5	41.8	44.3	46.1	49.4	52	59.8	64.1	67.1	67.2	72.1	75
	PGB	31.9	38.1	49.4	46.5	55.5	71.6	61.4	73.3	94.6	72	87.1	112	92.5	112	144	108	131	168
	PGC	35.3	40.7	50.5	57.9	66.7	82.7	78.5	90.4	111	97.2	112	138	131	151	187	158	182	224
	PGD	44	53.2	70.6	72	87	115	96.8	117	155	118	144	191	158	193	254	192	235	309
45	PGA	20.4	22.1	23.8	28.5	30.9	32.9	36.2	39.3	41.8	44.8	48	50.8	56.8	60.9	64	61.9	66.4	69.4
	PGB	31.2	37.2	48.3	45.2	54	69.8	57.4	68.5	88.5	69.5	84.1	108	87.6	106	137	99.1	120	154
	PGC	34.3	39.5	49	55.8	64.3	79.7	72	82.9	102	93.7	108	133	121	139	172	142	164	202
	PGD	42.9	51.8	68.7	69.5	84	111	88.6	107	142	114	139	183	146	179	236	172	211	279
50	PGA	20.7	22.4	24.2	28.4	30.8	33	31.7	34.4	36.8	44.4	47.6	50.7	50	53.6	56.9	61.1	65.5	69.3
	PGB	31.3	27.4	48.7	44.7	53.3	69.2	49.8	59.4	76.9	68.2	82.5	106	76.4	92.5	119	96.7	117	151
	PGC	34.3	39.5	49.1	54.3	62.6	77.7	60.1	69.2	85.8	90.3	104	129	101	116	144	135	156	194
	PGD	42.7	51.6	68.5	67.8	81.9	108	74.7	90.3	119	109	134	177	122	149	197	166	203	269
56	PGA	19.1	20.7	22.4	26.3	28.5	30.7	31	33.6	36.2	41.3	44.3	47.5	48.6	52.1	55.7	56.6	60.7	64.8
	PGB	28.8	34.4	44.8	41.3	49.3	64	48.4	57.8	75.1	63.4	76.7	99.5	74	89.6	116	89.2	108	140
	PGC	30.9	35.6	44.2	49	56.4	70.1	57.9	66.7	82.9	82.2	94.7	117	96.3	111	138	122	140	174
	PGD	38.7	46.8	62.1	61.3	74.1	98.3	72.2	87.2	115	100	122	162	117	143	190	149	182	241
63	PGA	18.4	19.9	21.6	25.3	27.4	29.5	30.8	33.4	36	39.9	42.8	46.1	48	51.5	55.2	54.7	58.7	62.8
	PGB	27.7	33.1	43.2	39.6	47.3	61.6	47.8	57.1	74.2	61.2	74.1	96.2	72.8	88.1	114	85.9	104	135
	PGC	29.2	33.7	41.9	46.3	53.3	66.2	56.4	65	80.8	77.9	89.8	111	93.7	108	134	115	132	164
	PGD	36.7	44.3	58.9	58	70.1	93	70.4	85.1	112	95	116	154	114	140	185	141	173	229
71	PGA	17	18.4	20	24.1	26.1	28.2	28.4	30.8	33.3	38	40.8	43.9	44.6	47.8	51.4	51.3	55	59
	PGB	25.7	30.7	40	37.6	44.9	58.5	44.1	52.6	68.4	58.2	70.5	91.7	67.5	81.7	106	80.8	97.8	126
	PGC	26.6	30.6	38	42.8	49.3	61.3	51	58.8	73	72.1	83.1	103	85.3	98.3	122	103	119	148
	PGD	33.4	40.4	53.7	54	65.2	86.5	63.8	77.1	102	88	108	143	104	127	168	128	157	209
80	PGA								27.2	29.5	31.9				43.1	46.2	49.7		
	PGB								42.4	50.6	65.9				65.3	79	102		
	PGC								48.1	55.4	68.8				80.9	93.2	115		
	PGD								60.2	72.8	96.7				98.8	121	160		
90	PGA								26	28.2	30.5				41	44	47.4		
	PGB								40.3	48.1	62.7				62	75.1	97.6		
	PGC								44.6	51.4	63.8				74.9	86.3	107		
	PGD								56.2	67.9	90.1				91.5	112	149		

敬请垂询
 PGA (KW) 齿轮箱不带辅助冷却措施
 PGB (KW) 齿轮箱带冷却风扇
 PGC(KW) 齿轮箱带内置冷却盘管
 PGD(KW) 齿轮箱带冷却风扇和内置冷却盘管

On request
 PGA (kw) gear units without auxiliary cooling
 PGB (kw) gear units with fan
 PGC(kw) gear units with built-in cooling coil
 PGD(kw) gear units with fan and built-in cooling coil



齿轮箱
热功率
类型 V3
规格 11-15

Gear Units
Thermal Capacities
Type V3
sizes 11-15

i _N		热功率P _G (Kw)/Thermal capacities P _G (Kw)																	
		齿轮箱规格/Gear unit sizes (11-15)																	
		10			11			12			13			14			15		
n ₁		750	1000	1500	750	1000	1500	750	1000	1500	750	1000	1500	750	1000	1500	750	1000	1500
12.5	P _{GA}				131	140	112				166	172	*				213	221	*
	P _{PB}				265	321	377				355	419	468				493	583	602
	P _{GC}				396	456	542				620	714	831				969	1117	1261
	P _{GD}				501	613	768				761	923	1126				1163	1410	1652
14	P _{GA}				130	139	117				171	177	127				212	220	*
	P _{PB}				260	315	374				359	424	482				476	562	598
	P _{GC}				388	447	533				624	719	843				925	1066	1217
	P _{GD}				490	600	756				769	932	1147				1113	1349	1603
16	P _{GA}	103	110	103	124	133	114	145	155	125	159	165	122	184	191	138	213	264	*
	P _{PB}	177	214	262	248	300	358	287	347	407	328	388	445	379	448	511	468	434	597
	P _{GC}	298	343	415	369	425	508	483	557	662	568	654	769	642	740	868	905	860	1196
	P _{GD}	354	434	558	465	569	719	591	724	907	698	846	1047	791	959	1181	1091	999	1583
18	P _{GA}	95.1	102	96.3	123	132	115	145	156	129	161	167	128	188	195	146	208	216	*
	P _{PB}	163	197	243	242	293	353	287	347	411	332	392	454	382	452	520	449	531	581
	P _{GC}	273	315	383	361	416	499	484	558	665	571	658	777	647	745	877	869	1001	1155
	P _{GD}	326	399	514	456	558	707	593	726	913	704	853	1060	796	965	1195	1044	1265	1525
20	P _{GA}	97.9	105	100	118	126	112	137	147	124	153	159	126	174	180	140	205	212	*
	P _{PB}	168	203	251	231	280	339	267	323	385	311	367	428	349	413	480	434	513	568
	P _{GC}	280	323	392	344	396	476	448	516	616	534	615	729	588	677	800	834	961	1114
	P _{GD}	335	410	529	434	531	676	549	672	848	658	798	996	724	877	1092	1002	1215	1475
22.4	P _{GA}	90.9	97.5	93.9	114	122	110	138	148	128	149	154	126	179	185	148	203	210	*
	P _{PB}	154	186	231	220	266	324	268	324	388	295	349	412	353	417	489	421	498	559
	P _{GC}	256	295	360	319	367	443	447	515	617	498	574	683	593	683	811	790	910	1061
	P _{GD}	306	375	485	404	495	632	548	671	850	615	746	936	730	885	1107	953	1155	1412
25	P _{GA}	87.9	94.3	92.8	109	117	109	134	144	130	144	149	128	170	176	150	197	204	153
	P _{PB}	147	178	223	207	250	307	255	309	375	278	329	395	330	390	466	394	466	537
	P _{GC}	246	284	347	292	337	408	424	489	590	457	527	632	554	638	762	714	823	970
	P _{GD}	293	359	466	371	454	584	523	640	817	567	687	870	682	827	1045	864	1047	1297
28	P _{GA}	86.5	92.7	93.1	105	113	109	131	140	131	139	144	131	166	172	155	198	205	168
	P _{PB}	144	174	220	197	238	296	244	295	363	264	312	380	316	373	452	383	453	535
	P _{GC}	238	274	336	272	313	382	396	456	554	424	489	590	515	593	715	685	789	939
	P _{GD}	285	349	455	346	424	549	487	596	767	528	640	819	637	772	985	831	1007	1265
31.5	P _{GA}	83.1	89.1	90.7	101	108	106	124	133	129	134	139	131	159	165	154	189	196	170
	P _{PB}	136	165	210	186	225	282	228	276	344	250	296	365	296	350	430	358	423	508
	P _{GC}	220	254	312	253	291	356	362	417	508	393	453	550	471	543	658	621	715	857
	P _{GD}	265	324	424	323	395	514	448	548	709	491	595	766	586	710	912	757	917	1162
35.5	P _{GA}	79.5	85.3	87.7	97.9	105	105	119	128	125	130	135	130	153	159	151	185	192	173
	P _{PB}	129	156	199	178	215	271	216	262	328	240	284	353	281	332	412	344	407	495
	P _{GC}	206	237	292	240	276	338	338	389	475	374	431	524	439	506	615	590	680	819
	P _{GD}	247	302	396	305	373	487	416	509	661	467	566	732	546	662	855	720	873	1114
40	P _{GA}	76.1	81.6	84.4	92.9	99.6	100	114	122	121	124	128	125	147	152	147	177	183	168
	P _{PB}	123	149	191	166	201	255	203	246	310	226	267	334	267	315	392	324	383	469
	P _{GC}	193	222	274	220	253	310	312	360	440	345	397	484	409	471	574	544	627	758
	P _{GD}	231	283	372	281	344	449	386	473	616	431	523	678	509	617	798	667	808	1035
45	P _{GA}	72.5	77.7	80.8	85.4	91.6	93.2	109	117	118	115	119	117	142	147	144	165	171	160
	P _{PB}	116	140	180	152	184	234	195	236	298	206	244	306	255	301	377	298	352	434
	P _{GC}	176	203	251	197	227	280	295	340	417	309	356	435	387	446	544	490	564	684
	P _{GD}	212	260	342	254	311	407	367	449	585	385	467	607	483	586	760	601	728	936
50	P _{GA}	68.2	73.1	77	86.2	92.4	95.8	104	112	115	118	122	124	136	141	142	172	178	174
	P _{PB}	108	131	169	150	181	232	183	221	281	206	244	310	239	283	358	301	356	445
	P _{GC}	160	184	228	193	222	274	271	312	384	306	352	433	358	412	506	492	567	692
	P _{GD}	193	236	312	246	301	396	336	411	539	384	466	610	448	543	709	601	728	944
56	P _{GA}	63.1	67.7	72	78.8	84.5	88.9	96.1	103	108	109	113	117	126	131	135	159	165	167
	P _{PB}	99.1	120	155	135	164	211	168	203	260	189	223	285	218	258	330	275	325	411
	P _{GC}	144	166	206	171	197	243	242	279	345	273	315	389	318	366	451	440	507	622
	P _{GD}	174	213	281	219	268	354	302	370	488	343	416	547	401	486	637	538	652	852
63	P _{GA}	62	66.5	71	76.2	81.7	86.3	96.1	103	108	105	109	114	128	133	138	153	159	162
	P _{PB}	96.7	117	151	131	158	203	164	198	255	181	214	275	219	259	332	261	309	393
	P _{GC}	138	159	197	161	185	229	235	271	335	257	296	366	317	365	451	412	475	585
	P _{GD}	166	203	269	207	253	334	292	358	471	324	393	517	397	481	633	505	612	802
71	P _{GA}	57.5	61.7	65.9	70.6	75.7	80.2	88.4	94.8	99.9	99.4	103	107	118	122	127	146	151	155
	P _{PB}	89.2	108	140	121	146	189	149	180	232	170	201	258	200	236	302	247	292	372
	P _{GC}	124	143	177	144	166	206	208	240	297	233	268	331	284	327	404	379	437	538
	P _{GD}	149	183	243	186	228	301	261	319	421	294	356	469	356	431	567	468	567	743
80	P _{GA}	55.6	59.6	63.8				84.6	90.7	95.8				113	117	123			
	P _{PB}	86.7	105	136				143	173	224				192	227	291			
	P _{GC}	116	134	167				194	224	278				266	307	379			
	P _{GD}	142	174	231				245	300	396				336	407	536			
90	P _{GA}	52.1	55.9	60				78.8	84.5	89.6				106	110	115			
	P _{PB}	81.3	98.4	127				133	161	208				179	212	273			
	P _{GC}	105	121	151				174	201	249				240	277	343			
	P _{GD}	130	159	210				221	271	357				304	369	487			

*敬请垂询
PGA(KW) 齿轮箱不带辅助冷却措施
PGB(KW) 齿轮箱带冷却风扇
PGC(KW) 齿轮箱带内置冷却盘管
PGD(KW) 齿轮箱带冷却风扇和内置冷却盘管

*On request
PGA(KW) Gear units without auxiliary cooling
PGB(KW) Gear units with fan
PGC(KW) Gear units with built-in cooling coil
PGD(KW) Gear units with fan and built-in cooling coil



齿轮箱
热功率
类型 V3
规格 16-26

Gear Units
Thermal Capacities
Type V3
Sizes 16-26

		热功率P _G (Kw)/Thermal capacities P _G (Kw)																									
i _N	n1	齿轮箱规格/Gear unit sizes (17-22)																									
		16			17			18			19			20			21			22			23	24	25	26	
		750	1000	1500	750	1000	1500	750	1000	1500	750	1000	1500	750	1000	1500	750	1000	1500	750	1000	1500					
12.5	P _{GA}				227	235	*				*	*	*				*	*	*								
	P _{GB}				628	742	728				*	*	*				*	*	*								
	P _{GC}				1162	1339	1484				*	*	*				*	*	*								
	P _{GD}				1440	1745	1991				*	*	*				*	*	*								
14	P _{GA}	225	233	*	227	235	*	250	259	*	*	*	*	*	*	*	*	*	*	*	*	*	*	*	*	*	
	P _{GB}	511	604	631	606	716	728	675	798	792	*	*	*	*	*	*	*	*	*	*	*	*	*	*	*	*	
	P _{GC}	980	1129	1280	1116	1286	1443	1224	1410	1569	*	*	*	*	*	*	*	*	*	*	*	*	*	*	*	*	
	P _{GD}	1182	1433	1688	1384	1677	1947	1516	1838	2110	*	*	*	*	*	*	*	*	*	*	*	*	*	*	*	*	
16	P _{GA}	219	227	*	233	241	*	236	245	*	*	*	*	*	*	*	*	*	*	*	*	*	*	*	*	*	
	P _{GB}	490	579	615	603	713	737	619	732	741	*	*	*	*	*	*	*	*	*	*	*	*	*	*	*	*	
	P _{GC}	936	1079	1230	1098	1265	1429	1121	1292	1447	*	*	*	*	*	*	*	*	*	*	*	*	*	*	*	*	
	P _{GD}	1127	1366	1621	1365	1654	1937	1388	1682	1949	*	*	*	*	*	*	*	*	*	*	*	*	*	*	*	*	
18	P _{GA}	222	230	*	229	237	*	254	263	*	*	*	*	*	*	*	*	*	*	*	*	*	*	*	*	*	
	P _{GB}	485	573	617	580	686	722	646	763	787	*	*	*	*	*	*	*	*	*	*	*	*	*	*	*	*	
	P _{GC}	923	1063	1219	1050	1210	1375	1156	1332	1503	*	*	*	*	*	*	*	*	*	*	*	*	*	*	*	*	
	P _{GD}	1109	1344	1608	1307	1584	1872	1434	1738	2033	*	*	*	*	*	*	*	*	*	*	*	*	*	*	*	*	
20	P _{GA}	215	223	*	226	234	*	237	246	*	265	271	*	*	*	*	264	270	*	*	*	*	*	*	*	*	
	P _{GB}	464	548	599	560	662	708	592	700	736	689	814	839	*	*	*	761	899	813	*	*	*	*	*	*	*	
	P _{GC}	877	1010	1165	1010	1164	1332	1054	1214	1379	*	*	*	*	*	*	*	*	*	*	*	*	*	*	*	*	
	P _{GD}	1056	1280	1542	1256	1523	1815	1311	1589	1876	*	*	*	*	*	*	*	*	*	*	*	*	*	*	*	*	
22.4	P _{GA}	211	219	*	228	236	*	235	243	*	269	276	*	279	286	*	272	279	*	264	270	*	*	*	*	*	
	P _{GB}	447	528	586	547	646	702	571	675	722	673	795	836	705	833	864	745	881	824	767	907	793	*	*	*	*	
	P _{GC}	838	966	1121	697	1114	1282	1010	1164	1332	*	*	*	*	*	*	*	*	*	*	*	*	*	*	*	*	*
	P _{GD}	1012	1227	1490	1205	1461	1756	1258	1525	1818	*	*	*	*	*	*	*	*	*	*	*	*	*	*	*	*	
25	P _{GA}	214	222	160	225.8	234	*	241	250	*	274	281	*	290	297	*	285	292	*	284	291	*	*	*	*	*	
	P _{GB}	434	513	585	514	607	681	559	661	732	646	763	833	690	816	881	716	846	841	756	893	844	*	*	*	*	
	P _{GC}	798	919	1078	879	1013	1181	969	1116	1294	*	*	*	*	*	*	*	*	*	*	*	*	*	*	*	*	*
	P _{GD}	964	1168	1440	1100	1333	1629	1210	1467	1780	*	*	*	*	*	*	*	*	*	*	*	*	*	*	*	*	*
28	P _{GA}	208	216	172	230.7	239	183	239	248	182	278	25	200	295	302	*	294	301	*	299	306	*	*	*	*	*	
	P _{GB}	406	480	562	504	596	689	525	621	711	619	731	828	662	782	878	686	811	855	725	857	869	*	*	*	*	
	P _{GC}	722	832	987	851	980	1157	881	1015	1193	*	*	*	*	*	*	*	*	*	*	*	*	*	*	*	*	*
	P _{GD}	875	1060	1326	1066	1292	1605	1102	1336	1650	*	*	*	*	*	*	*	*	*	*	*	*	*	*	*	*	*
31.5	P _{GA}	208	215	183	223.9	232	190	241	250	199	272	279	216	295	302	227	292	299	*	305	312	*	*	*	*	*	
	P _{GB}	396	468	558	471	557	658	514	608	712	582	688	799	634	749	863	642	759	831	695	821	871	*	*	*	*	
	P _{GC}	692	797	952	778	896	1067	852	982	1165	*	*	*	*	*	*	*	*	*	*	*	*	*	*	*	*	*
	P _{GD}	842	1020	1288	977	1184	1487	1069	1296	1620	*	*	*	*	*	*	*	*	*	*	*	*	*	*	*	*	*
35.5	P _{GA}	198	205	181	220	228	196	233	241	203	271	228	228	286	293	235	290	297	*	299	306	*	*	*	*	*	
	P _{GB}	368	435	526	455	538	644	481	569	677	564	786	786	595	703	825	619	731	821	649	767	839	*	*	*	*	
	P _{GC}	629	725	871	740	853	1021	779	897	1071	*	*	*	*	*	*	*	*	*	*	*	*	*	*	*	*	*
	P _{GD}	766	929	1181	931	1129	1429	980	1188	1498	*	*	*	*	*	*	*	*	*	*	*	*	*	*	*	*	*
40	P _{GA}	192	199	180	212	220	194	228	236	204	261	226	226	282	289	240	280	287	208	295	302	*	*	*	*	*	
	P _{GB}	355	419	510	430	508	614	464	548	657	531	474	747	575	679	805	580	686	783	624	738	822	*	*	*	*	
	P _{GC}	596	687	829	688	793	954	740	853	1022	*	*	*	*	*	*	*	*	*	*	*	*	*	*	*	*	*
	P _{GD}	729	884	1129	869	1053	1339	934	1132	1434	*	*	*	*	*	*	*	*	*	*	*	*	*	*	*	*	*
45	P _{GA}	183	190	176	199	206	187	220	228	203	247	221	221	271	278	240	264	270	207	284	291	206	*	*	*	*	
	P _{GB}	334	395	484	398	470	572	440	520	629	492	700	700	540	638	765	536	634	733	586	692	785	*	*	*	*	
	P _{GC}	550	634	768	624	719	868	693	798	960	*	*	*	*	*	*	*	*	*	*	*	*	*	*	*	*	*
	P _{GD}	675	818	1049	788	955	1221	872	1057	1346	*	*	*	*	*	*	*	*	*	*	*	*	*	*	*	*	*
50	P _{GA}	173	179	174	211	219	210	208	216	204	250	240	240	261	267	247	295	302	260	276	283	232	*	*	*	*	
	P _{GB}	307	363	453	404	478	593	407	481	594	475	690	690	503	595	730	565	668	799	542	641	757	*	*	*	*	
	P _{GC}	496	571	696	631	727	884	629	725	880	*	*	*	*	*	*	*	*	*	*	*	*	*	*	*	*	*
	P _{GD}	609	738	956	794	962	1242	794	963	1240	*	*	*	*	*	*	*	*	*	*	*	*	*	*	*	*	*
56	P _{GA}	180	186	186	198	205	203	220	228	225	245	245	245	262	268	260	287	294	271	305	312	279	*	*	*	*	
	P _{GB}	309	365	461	371	438	552	413	488	612	457	675	675	483	571	712	533	630	772	571	675	818	*	*	*	*	
	P _{GC}	497	573	702	568	654	800	633	729	891	*	*	*	*	*	*	*	*	*	*	*	*	*	*	*	*	*
	P _{GD}	609	738	962	715	867	1128	797	966	1255	*	*	*	*	*	*	*	*	*	*	*	*	*	*	*	*	*
63	P _{GA}	165	171	173	191	198	199	204	211	211	239	243	243	254	260	256	280	287	272	291	298	275	*	*	*	*	
	P _{GB}	282	333	422	355	419	529	378	447	563	440	654	654	465	549	689	514	608	752	536	633	776	*	*	*	*	
	P _{GC}	443	510	627	534	615	755	570	657	805	*	*	*	*	*	*	*	*	*	*	*	*	*	*	*	*	*
	P _{GD}	544	659	862	677	820	1071	717	869	1133	*	*	*	*	*	*	*	*	*	*	*	*	*	*	*	*	*
71	P _{GA}	158	164	167	180	187	190	197	204	205	226	232	232	246	252	251	266	272	261	284	291	273	*	*	*	*	
	P _{GB}	269	318	404	333	393	498	360	426	539	412	487	615	448	529	666	481	569	707	518	612	754	*	*	*	*	
	P _{GC}	417	481	591	494	569	698	538	620	760	*	*	*	*	*	*	*	*	*	*	*	*	*	*	*	*	*
	P _{GD}	512	621	813	625	757	990	680	824	1075	*	*	*	*	*	*	*	*	*	*	*	*	*	*	*	*	*
80	P _{GA}	152	157	161				186	193	196				233	239	240				269	276	262		*	*	*	
	P _{GB}	255	301	384				338	400	507				419	495	626				486	574	710		*	*	*	
	P _{GC}	384	442	544				495	570	700				*	*	*											

齿轮箱

公称功率和输出扭矩

类型 V4

规格 5-15

Gear Units

Nominal Power Rating and output Torque

Type V4

Sizes 5-15

公称功率 P_{2N} (Kw) 和公称输出扭矩 T_{2N} (KN.m) / Nominal power ratings P_{2N} (Kw) and output torque T_{2N} (KN.m)

i_N	n_1	n_2	齿轮箱规格/Gear unit sizes (5-15)																							
			5		6		7		8		9		10		11		12		13		14		15			
			P_{2N}	T_{2N}	P_{2N}	T_{2N}	P_{2N}	T_{2N}	P_{2N}	T_{2N}	P_{2N}	T_{2N}	P_{2N}	T_{2N}	P_{2N}	T_{2N}	P_{2N}	T_{2N}	P_{2N}	T_{2N}	P_{2N}	T_{2N}	P_{2N}	T_{2N}		
80	1500	18.8	23			44				74					127			187					316	160		
	1000	12.5	16	12			29	22.5		48	36.9			84	64.2			124	94.7				210			
	750	9.4	12				22			36				63				93					158			
90	1500	16.7	21			39				65					112			166					280	160		
	1000	11.1	14	11.7			26	22.6		43	37			75	64.1			110	94.8				186			
	750	8.3	10				20			32				56				83					139			
100	1500	15	19		25		36		44	59			72		101		128		149		186		252	160		
	1000	10	13	12	17	16	23	22.1	29	28.1	39	37.1	48	46.1	67	64.2	85	81.2	99	94.3	124	118	168			
	750	7.5	9.5		13		17		22		29		36		50		64		74		93		126			
112	1500	13.4	17		22		32		40	53			65		90		114		133		166		225	159		
	1000	8.9	11	11.2	15	15.7	21	22.5	26	28.1	35	37.1	43	46	60	64	76	80.9	88	94.3	110	118	149			
	750	6.7	7.9		11		16		20		26		32		45		57		66		83		112			
125	1500	12	15		20		28		36	46			58		81		103		119		148		202	160		
	1000	8	10	12.2	13	15	19	22.6	23	27.6	30	36.3	39	46.4	54	63.9	68	81.5	79	94	99	118	134			
	750	6	7.6		9.5		14		17		23		29		40		51		59		74		101			
140	1500	10.7	12		17		24		29	38			48		68		85		99		123		168	148		
	1000	7.1	8.4	11.3	11	14.4	16	21	20	26.2	25	34.1	31	41.9	44	59	56	74.7	66	87.8	82	110	111			
	750	5.4	6.3		8.1		12		15		19		24		33		42		49		62		83			
160	1500	9.4	11		15		21		25	34			42		59		74		87		109		147	150		
	1000	6.3	7.4	11.4	9.8	15	14	21	17	25.5	23	34.4	28	43.4	39	59.9	50	76.4	58	88.3	73	111	98			
	750	4.7	5.6		7.4		10		12		17		21		29		37		43		54		74			
180	1500	8.3	10		13		18		23	30			37		52		66		76		96		129	150		
	1000	5.6	6.7	11.5	8.8	15.2	12	20.2	15	25.3	20	33.7	25	42.1	35	60.6	44	75.8	52	89.3	65	111	87			
	750	4.2	5		6.6		8.8		11		15		18		26		33		39		49		65			
200	1500	7.5	8.9		12		17		21	27			33		47		60		70		86		118	150		
	1000	5	5.9	11.2	7.9	15.2	11	20.6	14	26.2	18	33.7	23	43.1	31	59.9	39	74.9	46	88	58	110	78			
	750	3.8	4.4		6.0		8.1		10		13		17		24		29		35		43		59			
224	1500	6.7	7.9		9.8		15		19	25			30		42		53		62		77		105	151		
	1000	4.5	5.3	11.3	7.2	15.3	10	21	12	25.2	16	33.5	20	41.9	28	60.8	35	75.5	41	88	52	111	71			
	750	3.3	4		5.4		7.4		8.8		12		15		21		26		31		39		53			
250	1500	6	6.8		9.2		12		16	21			26		36		47		53		67		91	145		
	1000	4	4.6	10.9	6.1	14.5	8.6	20.4	10	24.9	13	31.8	17	40.8	24	56.7	30	73.7	35	83.9	45	107	61			
	750	3	3.4		4.6		6.4		7.8		10		13		18		23		26		33		46			
280	1500	5.4	6.2		8.3		11		14	18			23		32		42		48		60		82	145		
	1000	3.6	4.1	10.9	5.5	14.7	7.7	20.6	9.5	25.4	12	33.0	15	40.6	22	58.4	28	73.7	32	86.4	40	107	54			
	750	2.7	3.1		4.1		5.8		7.1		9.3		11		16		21		24		30		41			
315	1500	4.8	5.3		7.3		9.5		12	16			21		29		37		43		53		72	146		
	1000	3.2	3.5	10.6	4.8	14.6	6.5	19.4	8.6	26	10	31.4	13	40.0	19	57.2	25	74.3	29	85.7	35	106	48			
	750	2.4	2.6		3.6		4.8		6.5		7.8		10		14		19		21		26		36			
355	1500	4.2			6.5				10				18				32				47			106		
	1000	2.8			4.3	14.5			7.3	24.8			11	38.6			21	70.9			31					
	750	2.1			3.2				5.5				8.6				16				24					
400	1500	3.8			5.4				9.5				16				28				42			105		
	1000	2.5			3.5	13.4			6.3	24			10	39.9			18	69			28					
	750	1.9			2.6				4.7				7.8				14				21					



齿轮箱

公称功率和输出扭矩

类型 V4

规格 16-26

Gear Units

Nominal Power Rating and output Torque

Type V4

Sizes 16-26

公称功率 P_{2N} (Kw)和公称输出扭矩 T_{2N} (KN.m)/Nominal power ratings P_{2N} (Kw) and output torque T_{2N} (KN.m)

i_N	n_1	n_2	齿轮箱规格/Gear unit sizes (16-26)																							
			16		17		18		19		20		21		22		23		24		25		26			
			P_{2N}	T_{2N}	P_{2N}	T_{2N}	P_{2N}	T_{2N}	P_{2N}	T_{2N}	P_{2N}	T_{2N}	P_{2N}	T_{2N}	P_{2N}	T_{2N}	P_{2N}	T_{2N}	P_{2N}	T_{2N}	P_{2N}	T_{2N}	P_{2N}	T_{2N}		
80	1500	18.8				413				620				867				1157				1653				
	1000	12.5				274	209			412	314			576	440			769	587			1099	840			
	750	9.4				206				309				432				576				825				
90	1500	16.7	317			366		440		550		633		771		862		1028		1175		1468		1652		
	1000	11.1	211	181		244	209	292	251	365	314	420	361	512	440	573	493	683	587	780	671	975	838	1098		
	750	8.3	158			183		219		274		315		384		430		512		585		732		824		
100	1500	15	285			330		395		495		568		692		775		923		1055		1319		1484		
	1000	10	190	181		219	210	264	252	330	315	379	362	461	440	517	493	615	588	704	672	879	839	989		
	750	7.5	143			165		198		247		284		346		387		461		528		659		742		
112	1500	13.4	254			294		353		441		508		618		692		824		943		1178		1325		
	1000	8.9	169	181		195	209	234	250	293	313	337	361	411	439	460	492	547	585	626	669	782	837	880		
	750	6.7	127			146		176		220		253		308		345		410		469		587		660		
125	1500	12	228			264		316		395		455		553		620		738		844		1055		1187		
	1000	8	151	180		175	209	211	252	264	315	303	362	369	440	413	493	492	588	563	672	704	840	791		
	750	6	113			132		158		198		228		276		309		369		422		528		593		
140	1500	10.7	189			220		263		329		378		461		515		614		703		878		988		
	1000	7.1	125	168		145	194	174	233	219	292	251	335	306	409	342	457	408	545	466	622	582	778	656		
	750	5.4	94			109		131		164		188		229		257		306		349		437		492		
160	1500	9.4	167			192		231		289		332		405		453		540		616		771		867		
	1000	6.3	112	171		128	196	155	237	193	295	222	340	271	415	304	464	362	553	414	632	516	789	581		
	750	4.7	84			96		116		145		167		204		228		271		310		387		436		
180	1500	8.3	147			170		204		255		293		358		400		476		545		681		766		
	1000	5.6	99	170		115	197	137	236	172	295	198	340	241	414	270	463	321	553	368	632	460	790	516		
	750	4.2	74			86		103		129		148		181		202		241		276		345		387		
200	1500	7.5	132			154		184		230		265		322		362		430		492		615		692		
	1000	5	88	168		102	195	123	234	154	294	176	337	215	410	241	460	287	548	328	627	410	782	462		
	750	3.8	66			76		92		115		132		161		181		215		246		307		346		
224	1500	6.7	119			137		165		206		237		288		322		384		440		550		618		
	1000	4.5	79	170		92	197	111	237	138	296	159	340	193	413	217	463	258	551	295	631	368	788	416		
	750	3.3	60			69		83		104		119		145		162		193		221		276		312		
250	1500	6	103			119		143		179		205		250		280		333		382		477		537		
	1000	4	68	163		79	188	95	227	119	284	137	327	166	397	186	445	222	531	255	608	318	760	357		
	750	3	51			59		71		89		103		125		140		167		191		239		268		
280	1500	5.4	92			107		128		161		185		225		252		300		343		429		483		
	1000	3.6	62	165		71	191	86	229	107	287	124	330	150	401	168	450	200	536	229	612	286	765	322		
	750	2.7	46			53		64		81		93		113		126		150		172		214		242		
315	1500	4.8	82			95		114		143		164		200		224		267		305		382		429		
	1000	3.2	54	163		64	191	76	229	95	286	109	329	133	400	149	449	178	534	203	612	255	766	286		
	750	2.4	41			48		57		71		82		100		112		133		152		191		214		
355	1500	4.2	72					100				143				196				267				375		
	1000	2.8	48	161				67	225			96	325			130	441			178	602			250		
	750	2.1	36					50				72				98				133				187		
400	1500	3.8																								
	1000	2.5																								
	750	1.9																								



齿轮箱

Gear Units

热功率

Thermal Capacities

类型 V4

Type V4

规格 5-26

Sizes 5-26

n1=750rpm

n1=750rpm

iN	热功率PG(KW)/Thermal capacities PG(KW)																													
	齿轮箱规格/ Gear unit sizes(5-26)																													
	5	6	7	8	9	10	11	12	13	14	15	16	17	18	19	20	21	22	23	24	25	26								
80	PGA	26.7		39.6		56		84.6		113		151		171		234		328	*	*	*	*								
90	PGA	26		38.3		54.7		82.1		110		145		156		163		176		224		239		317		332	*	*	*	*
100	PGA	24.8	28.6	36.2	42.3	51.9	56.4	78.8	94.3	105	121	136	149	153	168	212	230	298	321	*	*	*	*							
112	PGA	23.9	27.9	34.9	41.1	50	55.1	75.1	91.2	99.9	118	130	141	147	158	202	217	289	301	*	*	*	*							
125	PGA	22.9	26.7	33.3	38.9	47.6	52.3	71.9	87.1	95.3	111	123	135	139	150	191	206	272	292	*	*	*	*							
140	PGA	21.8	25.7	31.7	37.5	44.9	50.3	68	82.9	91.2	106	120	128	135	144	185	197	262	275	*	*	*	*							
160	PGA	20.1	24.5	28.9	35.7	41.1	47.9	62	79.5	86.3	103	113	123	127	138	175	190	248	265	*	*	*	*							
180	PGA	19.7	23.4	28.1	34	40.1	45.5	60.3	75.3	81.5	96.2	106	116	120	130	163	178	232	251	*	*	*	*							
200	PGA	19	21.6	27.9	31	39.2	41.7	59	68.7	79.6	92	105	109	118	123	163	167	224	234	*	*	*	*							
224	PGA	17.7	21.2	26	30.3	36.7	40.5	55.5	67.1	74.6	87.1	98.1	108	109	121	152	167	209	227	*	*	*	*							
250	PGA	17.3	20.3	25.1	30	35.4	39.7	53.7	65.5	72.2	84.6	95.3	101	106	114	148	157	203	212	*	*	*	*							
280	PGA	16.4	19	23.5	28	33.7	37.2	51.4	61.5	68.2	79.6	88.7	97.1	100	109	138	150	193	205	*	*	*	*							
315	PGA	15.4	18.5	22	26.9	31.7	35.9	47.9	59.5	65	77	83.8	92	94.3	103	131	143	180	196	*	*	*	*							
355	PGA		17.7		25.3		34.2		56.8		72.7		86.3		97.1		135		183		*	*	*	*						
400	PGA		16.5		23.7		32.2		53		69.2																			

n1=1000rpm

n1=1000rpm

iN	热功率PG(KW)/Thermal capacities PG(KW)																											
	齿轮箱规格/ Gear unit sizes(5-26)																											
	5	6	7	8	9	10	11	12	13	14	15	16	17	18	19	20	21	22	23	24	25	26						
80	PGA	28.6		42.4		60		90.6		121		162		183		250		351	*	*	*	*						
90	PGA	27.9		41		58.6		87.9		118		155		167		188		240		256		339		355	*	*	*	*
100	PGA	26.6	30.6	38.3	45.3	55.6	60.4	84.4	101	112	130	146	160	164	180	227	246	319	344	*	*	*	*					
112	PGA	25.6	29.9	37.4	44	53.5	59	80.4	97.6	107	126	139	151	157	169	216	232	309	322	*	*	*	*					
125	PGA	24.5	28.6	35.7	41.6	51	56	77	93.2	102	119	132	144	149	161	205	221	291	313	*	*	*	*					
140	PGA	23.4	27.5	33.9	40.1	48.1	53.9	72.8	88.8	97.6	114	128	137	144	154	198	211	281	294	*	*	*	*					
160	PGA	21.5	26.3	30.9	38.2	44	51.3	66.4	85.1	92.4	110	121	132	136	148	187	203	265	284	*	*	*	*					
180	PGA	21.2	25.1	30.1	36.4	42.9	48.7	64.6	80.6	87.2	103	114	124	128	139	175	191	248	269	*	*	*	*					
200	PGA	20.4	23.1	29.9	33.2	42	44.6	63.2	73.6	85.2	98.5	112	117	126	132	174	179	240	251	*	*	*	*					
224	PGA	19	22.7	27.8	32.4	39.3	43.4	59.4	71.8	79.9	93.2	105	116	117	130	163	179	224	243	*	*	*	*					
250	PGA	18.5	21.8	26.9	32.1	37.9	42.5	57.5	70.1	77.3	90.6	102	108	114	122	158	168	217	227	*	*	*	*					
280	PGA	17.6	20.4	25.2	30	36.1	39.8	55	65.8	73	85.2	95	104	107	117	148	161	207	220	*	*	*	*					
315	PGA	16.5	19.8	23.6	28.8	33.9	38.4	51.3	63.7	69.6	82.4	89.7	98.5	101	110	140	153	193	210	*	*	*	*					
355	PGA		19		27.1		36.6		60.8		77.8		92.4		104		144		196		*	*	*	*				
400	PGA		17.7		25.4		34.5		56.7		74.1																	

n1=1500rpm

n1=1500rpm

iN	热功率PG(KW)/Thermal capacities PG(KW)																													
	齿轮箱规格/ Gear unit sizes(5-26)																													
	5	6	7	8	9	10	11	12	13	14	15	16	17	18	19	20	21	22	23	24	25	26								
80	PGA	31.7		46.9		66.1		98.6		130		171		189		256		343	*	*	*	*								
90	PGA	31.3		45.5		64.7		95.9		128		164		175		183		195		248		264		337		345	*	*	*	*
100	PGA	29.6	34	43.1	50.2	61.5	66.7	92.4	110	121	140	156	169	173	188	236	255	321	339	*	*	*	*							
112	PGA	28.6	33.3	41.5	48.8	59.2	65.3	88.3	106	116	137	149	161	167	179	227	243	315	323	*	*	*	*							
125	PGA	27.4	31.8	39.7	46.2	56.6	62.1	84.8	102	112	130	143	155	159	172	218	234	300	318	*	*	*	*							
140	PGA	26.1	30.7	37.8	44.6	53.5	59.9	80.4	97.8	107	125	139	148	155	165	211	225	294	304	*	*	*	*							
160	PGA	24.1	29.4	34.5	42.7	49	57.2	73.6	94.1	101	121	132	143	147	160	202	218	281	298	*	*	*	*							
180	PGA	23.6	28.1	33.7	40.7	47.9	54.3	71.8	89.3	96.5	114	125	136	140	152	190	208	266	286	*	*	*	*							
200	PGA	22.8	25.9	33.5	37.2	47	49.8	70.5	81.9	94.7	109	124	130	139	146	191	196	260	271	*	*	*	*							
224	PGA	21.3	25.4	31.2	36.4	44	48.6	66.5	80.2	89.1	104	117	128	130	144	181	198	246	266	*	*	*	*							
250	PGA	20.8	24.5	30.2	36	42.5	47.8	64.5	78.6	86.6	101	114	120	127	136	176	187	241	252	*	*	*	*							
280	PGA	19.8	22.9	28.4	33.7	40.6	44.8	61.8	74	82.1	95.9	106	117	120	132	167	182	233	247	*	*	*	*							
315	PGA	18.6	22.3	26.6	32.4	38.2	43.2	57.8	71.6	78.4	92.7	100	110	113	124	158	172	217	236	*	*	*	*							
355	PGA		21.3		30.4		41.2		68.4		87.6		103		117		162		220		*	*	*	*						
400	PGA		19.9		28.6		38.9		63.8		83.4																			

* 敬请垂询

* On request

P_{GA} (KW) 齿轮箱不带辅助冷却措施

P_{GA} (KW) Gear units without auxiliary cooling



齿轮箱

实际传动比

类型P1..., P2..., P3..., P4...

规格3-14

Gear Units

Actual Ratios

Type P1..., P2..., P3..., P4...

Sizes 3-14

实际传动比I/Actual Ratios I												
齿轮箱规格/Gear Units Sizes												
In	3	4	5	6	7	8	9	10	11	12	13	14
1.3	1.250		1.258		1.250		1.250		1.265		0.000	
1.4	1.400		1.414		1.400		1.400		1.406		1.400	
1.6	1.571		1.593		1.571		1.571		1.621		1.593	
1.8	1.769		1.800		1.769		1.769		1.815		1.800	
2.0	2.000		2.000		2.000		2.000		2.040		2.000	
2.2	2.227		2.227		2.273		2.273		2.208		2.227	
2.5	2.550		2.550		2.550		2.476		2.500		2.500	
2.8	2.789		2.789		2.789		2.789		2.800		2.800	
3.2	3.150		3.190		3.143		3.200		3.143		3.143	
3.6	3.611		3.500		3.579		3.526		3.579		3.579	
4.0	3.941		3.944		4.059		4.050		3.944		3.944	
4.5	4.556		4.421		4.444		4.421		4.421		4.421	
5.0	4.941		5.000		5.000		4.947		5.000		5.000	
5.6	5.579		5.611		5.526		5.647		5.526		5.611	
6.3		6.271	6.188		6.375		6.370		6.188		6.188	
7.1		7.088	6.966		7.138		7.200		6.966		6.966	
8.0		8.046	7.875	7.759	7.715	7.995	8.000	7.869	7.875	7.759	7.875	7.759
9.0		8.770	8.770	8.736	8.686	8.953	8.909	8.894	8.949	8.736	8.949	8.736
10.0		9.844	10.041	9.875	9.833	9.677	10.200	9.882	10.041	9.875	9.750	9.875
11.2		11.097	10.984	10.997	11.013	10.894	11.458	11.005	10.984	11.222	10.984	11.222
12.5		12.600	12.403	12.591	12.674	12.333	12.762	12.600	12.375	12.591	12.600	12.226
14		13.885	14.219	13.773	14.077	13.813	14.000	13.783	14.092	13.773	13.885	13.773
16		15.750	15.518	15.518	15.515	15.896	15.778	15.765	15.982	15.518	15.947	15.800
18		18.030	17.938	17.830	17.389	17.656	17.684	17.294	17.500	17.671	17.408	17.411
20		19.469	19.456	19.460	19.898	19.459	20.000	19.490	19.688	20.040	19.480	19.997
22.4		22.531	21.967	22.493	21.737	21.811	22.444	21.845	21.760	21.944	22.267	21.829
25			25.083	24.397	24.665	24.957	24.750	24.706	25.100	24.688	25.086	24.428
28			28.350	27.546	27.878	27.263	27.865	27.725	28.107	27.286	28.350	27.922
31.5			31.500	31.454	31.648	30.936	31.500	30.574	30.379	31.475	31.500	31.454
35.5			35.250	35.550	34.495	34.965	35.080	34.422	34.202	35.245	35.080	35.550
40			39.375	40.359	38.719	38.695	40.163	38.912	38.719	38.095	40.163	39.500
45			43.750	43.989	43.647	43.265	43.934	43.334	43.365	42.888	43.934	43.989
50			49.500	49.375	49.560	48.563	49.613	49.613	49.904	48.552	50.250	50.363
56			56.369	55.659	54.614	54.743	56.875	54.272	55.429	54.378	55.125	55.092
63			62.213	63.200	61.950	62.160	62.074	61.286	61.090	62.578	62.125	63.012
71			70.875	69.645	70.916	68.499	71.750	70.257	68.471	69.506	69.632	69.125
80			76.897	79.000	76.577	77.700	77.824	76.679	78.349	76.604	78.750	77.903
90			86.625	90.434	88.623	88.946	87.868	88.632	85.589	85.861	88.375	87.316
100				97.653	100.578	96.046	100.333	96.135	97.120	98.247	97.453	98.750
112				113.014	112.252	111.154	113.400	108.543	109.768	107.326	109.720	110.819
125					125.722	126.148	126.000	123.941	124.615	121.785	124.031	122.203
140					141.437	140.790	141.000	140.082	135.824	137.645	138.126	137.585
160					157.153	157.685	157.500	155.647	152.455	156.264	158.140	155.531
180					176.011	177.396	175.000	174.176	171.858	170.319	172.991	173.205
200					197.563	197.107	198.000	194.559	195.143	191.174	195.349	198.302
224					224.976	220.759	225.474	216.176	215.042	215.505	223.945	216.925
250					248.976	247.791	248.850	244.588	245.042	244.703	244.415	244.962
280					277.912	282.174	283.500	278.526	279.234	269.656	282.516	280.820
315					314.305	311.616	307.588	307.403	301.522	305.878	306.430	306.488
355					341.807	348.567	346.500	350.206	348.953	350.150	345.982	354.266
400						394.213		379.962		378.099		384.254
450							428.707		428.029		437.576	433.85



齿轮箱

实际传动比

类型 P1..., P2..., P3..., P4...

规格 15-26

Gear Units

Actual Ratios

Type P1..., P2..., P3..., P4...

Sizes 15-26

实际传动比I/Actual Ratios I											
齿轮箱规格/Gear Units Sizes											
15	16	17	18	19	20	21	22	23	24	25	26
0.000		0.000		0.000							
0.000		0.000		0.000							
1.593		1.600		1.586							
1.800		1.786		1.778							
2.000		2.000		2.000							
2.227		2.250		2.261							
2.500		2.545		2.500							
2.789		2.762		2.800							
3.200		3.105		3.190							
3.526		3.524		3.550							
4.000		3.947		4.048							
4.529		4.526		4.579							
4.944		4.944		5.000							
5.667		5.556		5.611							
6.483		6.271		6.282		6.370					
7.259	7.341	7.088	7.167	7.100	7.167	7.200	7.214				
8.160	8.220	7.875	8.100	7.889	8.100	8.000	8.153				
8.833	9.240	8.770	9.000	8.785	9.000	8.909	9.059				
10.000	10.002	9.844	10.023	9.861	10.023	10.000	10.088				
11.200	11.324	10.984	11.250	11.003	11.250	11.158	11.324				
12.571	12.682	12.434	12.553	12.622	12.553	12.800	12.635				
14.316	14.235	13.781	14.211	13.909	14.400	14.105	14.494				
15.778	16.211	15.531	15.750	15.778	15.868	16.000	15.972				
17.681	17.866	17.408	17.750	17.866	18.000	18.118	18.118				
20.000	20.025	19.688	19.895	19.503	20.382	19.778	20.516				
22.050	22.647	21.705	22.500	21.744	22.250	22.500	22.395				
24.750	24.968	24.363	24.806	24.406	24.806	25.931	25.478				
27.865	28.026	27.430	27.844	27.478	27.844	29.037	29.363				
31.500	31.553	31.008	31.349	31.063	31.349	32.640	32.880				
35.795	35.669	35.236	35.438	35.298	35.438	35.333	36.960				
40.163	40.533	39.535	40.270	38.458	40.270	40.000	40.010				
43.934	45.478	43.248	45.183	43.324	43.875	44.800	45.294				
49.500	49.749	48.727	49.426	49.700	49.426	50.286	50.729				
56.368	56.051	55.488	55.688	54.768	56.700	57.263	56.941				
63.926	63.829	62.928	63.414	62.902	62.482	63.111	64.842				
70.000	72.387	68.906	71.917	68.664	71.761	70.737	71.464				
78.750	79.265	77.520	78.750	76.839	78.336	80.000	80.099				
87.039	89.173	85.679	88.594	87.706	87.661	88.421	90.588				
100.402	98.559	98.833	97.919	98.940	100.059	99.000	100.124				
112.428	113.690	110.671	112.952	111.825	112.875	111.462	112.103				
121.517	127.308	119.619	126.481	124.250	127.575	126.000	126.214				
136.806	137.600	134.669	136.707	138.369	141.750	143.182	142.676				
154.875	154.913	152.455	153.907	158.419	157.858	160.650	162.132				
173.460	175.373	170.750	174.234	173.296	180.731	175.737	181.913				
199.617	196.418	196.498	195.143	198.208	197.704	198.000	198.996				
221.716	226.037	218.251	224.569	217.438	226.125	225.474	224.206				
244.358	251.061	240.540	249.430	245.049	248.063	255.706	255.316				
273.884	276.700	269.605	274.903	274.658	279.563	280.000	289.549				
313.394	310.134	308.497	308.120	310.625	313.342	315.000	317.059				
342.355	354.873	337.006	352.568	348.590	354.375	348.158	356.691				
	387.667		385.150		397.688		394.238				



齿轮箱
 实际传动比
 类型V2..., V3..., V4...
 规格4-14

Gear Units
 Actual Ratios
 Type V2... V3..., V4...
 Sizes 4-14

实际传动比I/Actual Ratios I											
齿轮箱规格/Gear Units Sizes											
I_N	4	5	6	7	8	9	10	11	12	13	14
5.0	5.054	4.998		4.992		5.077		4.958		4.958	
5.6	5.636	5.649		5.643		5.739		5.603		5.603	
6.3	6.322	6.375	6.267	6.368	6.262	6.286	6.271	6.188	6.218	6.375	6.218
7.1	6.934	7.046	7.084	7.039	7.078	7.158	7.090	7.125	7.026	7.125	7.026
8.0	7.978	7.875	7.994	8.085	7.987	8.222	7.765	7.875	7.759	8.091	7.994
9.0	8.890	8.801	8.836	8.792	8.828	8.911	8.842	8.801	8.935	8.801	8.935
10	9.837	9.844	9.875	10.079	10.141	10.250	10.157	10.090	9.875	10.090	10.149
11.2	11.327	11.207	11.037	11.195	11.027	11.077	11.045	10.904	11.037	11.207	11.037
12.5	12.531	12.827	12.344	12.174	12.642	12.786	12.662	12.496	12.652	12.901	12.652
14	14.222	14.485	14.053	13.936	14.041	13.923	13.683	14.229	13.673	14.169	14.053
16	16.135	15.639	16.138	15.661	15.435	16.032	15.885	15.875	16.036	15.771	16.077
18	18.480	17.928	18.223	18.107	17.669	17.487	17.298	17.801	18.261	18.325	17.653
20	20.151	19.859	19.610	20.201	19.643	19.990	19.805	19.657	19.906	19.990	19.650
22.4	22.520	22.193	22.481	22.527	22.711	22.598	21.602	22.221	22.326	22.598	22.978
25	25.234	24.868	24.902	25.269	25.337	25.500	24.694	25.075	24.650	24.750	25.067
28	28.599	28.184	27.830	27.714	28.255	28.184	27.915	27.714	27.865	28.184	28.337
31.5	31.963	31.500	31.184	31.886	31.693	31.500	31.500	31.835	31.443	32.375	31.036
35.5	35.724	35.206	35.342	35.530	34.761	35.206	34.816	34.619	34.753	35.206	35.342
40	40.569	39.981	39.314	39.314	39.993	39.375	38.912	39.687	39.921	40.359	40.597
45	45.486	44.827	44.147	45.271	44.563	44.827	43.490	44.080	43.411	43.615	44.147
50	50.404	49.673	50.135	50.037	49.310	49.673	48.610	48.845	49.766	49.673	50.609
56	55.936	56.438	56.212	55.497	56.781	56.438	55.374	55.497	55.275	56.438	54.692
63	62.595	63.000	62.288	63.241	62.758	63.000	61.391	61.950	61.250	61.688	62.288
71	70.585	70.875	70.771	70.984	69.606	70.875	69.717	69.694	69.591	69.563	70.771
80		80.115	79.000	79.260	79.319	79.435	77.824	79.542	77.683	78.712	77.354
90		87.868	88.875	88.577	89.031	88.773	87.551	88.701	87.394	88.979	87.229
100		98.206	100.462	99.254	99.410	99.474	98.125	99.497	99.743	100.406	98.703
112		109.760	110.184	112.488	111.096	112.737	109.660	109.126	111.228	110.975	111.577
125		124.646	123.147	125.722	124.488	126.000	122.879	125.551	124.766	124.031	125.906
140		139.755	137.635	140.513	141.087	140.824	139.263	139.900	136.840	138.623	139.160
160		162.417	156.302	159.570	157.685	159.923	155.647	154.801	157.437	155.039	155.531
180		175.825	175.248	178.912	176.237	179.308	173.958	178.255	175.430	176.506	173.829
200		192.180	203.666	198.254	200.139	198.692	197.552	197.019	194.115	195.588	194.414
224		217.055	220.478	220.014	224.398	225.750	221.498	218.519	223.526	222.223	221.333
250		246.531	240.988	246.206	248.658	252.000	245.443	249.010	247.055	248.063	245.261
280		271.688	272.180	277.636	275.949	283.500	278.868	279.501	274.016	279.070	278.660
315		306.906	309.142	309.067	308.800	309.750	311.294	304.910	312.251	304.910	341.063
355			340.688		348.222		350.206		350.485		349.945
400			384.851		387.643		382.632		382.318		382.348



齿轮箱
实际传动比
类型V2...,V3...,V4...
规格15-26

Gear Units
Actual Ratios
Type V2...,V3...,V4...
Sizes 15-26

实际传动比I/Actual Ratios I											
齿轮箱规格/Gear Units Sizes											
15	16	17	18	19	20	21	22	23	24	25	26
5.037											
5.692	5.704	5.603									
6.261	6.446	6.163									
7.048	7.090	7.125	7.043								
7.778	7.980	8./94	8.143								
8.941	8.807	8.801	9.250								
9.750	10.125	10.090	10.059								
11.077	11.040	10.904	11.531								
12.467	12.543	12.376	12.462	12.243		12.327					
14.095	14.167	13.476	14.202	13.902	14.018	13.998	14.009				
16.230	16.017	15.658	15.465	15.895	15.917	16.119	15.906				
17.778	18.379	17.792	17.895	17.515	18.133	17.762	18.252				
19.833	20.131	19.523	20.333	19.868	19.982	20.148	20.113				
22.413	22.458	22.063	22.313	22.453	22.667	22.769	22.815				
24.750	25.380	25.102	25.215	24.696	25.615	25.043	25.783				
28.500	28.026	28.055	28.688	27.799	28.174	28.190	28.358				
31.500	32.272	31.869	32.063	30.679	31.714	31.111	31.922				
35.206	35.669	34.665	36.422	35.268	35.000	35.765	35.229				
40.359	39.685	39.729	39.607	38.458	40.235	39.000	40.498				
43.615	45.701	44.127	45.404	43.692	43.875	44.308	44.162				
49.673	49.388	48.897	50.430	48.547	49.846	49.231	50.172				
55.125	56.247	55.556	55.882	55.222	55.385	56.000	55.747				
61.688	62.421	60.724	63.492	61.796	63.000	62.667	63.412				
69.563	69.852	68.476	69.398	69.685	70.500	70.667	70.961				
78.629	78.769	77.400	78.258	78.851	79.500	79.333	80.020				
88.885	89.036	87.496	88.457	89.136	89.957	89.654	89.833				
100.300	100.649	98.733	99.995	97.625	101.690	99.000	101.520				
110.858	113.575	109.126	112.838	111.171	111.375	114.000	112.103				
127.342	125.530	125.352	124.715	127.701	126.829	126.000	129.088				
138.476	144.196	136.313	143.259	138.868	145.688	140.824	142.676				
158.747	156.804	156.266	155.786	159.195	158.426	161.438	159.462				
176.319	179.757	173.564	178.590	172.038	181.617	174.462	182.804				
195.381	199.656	192.328	198.359	195.933	196.269	198.692	197.552				
221.988	221.240	218.519	219.803	222.615	223.529	220.500	224.990				
247.800	251.368	243.928	249.736	243.323	253.969	246.750	249.684				
278.775	280.597	274.419	278.775	274.385	277.594	278.250	279.408				
304.588	315.672	299.828	313.622	305.448	313.031	309.750	315.077				
	344.901		342.661		348.469		350.746				

齿轮箱

Gear Units

在输出轴d2上允许的
附加径向力¹⁾
实心轴(S)

Permissible Additional Radial
Forces on Output Shaft d₂ 1)
Solid Shaft (S)

作用力在轴伸中部
Application of force on centre of shaft end

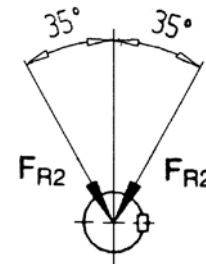
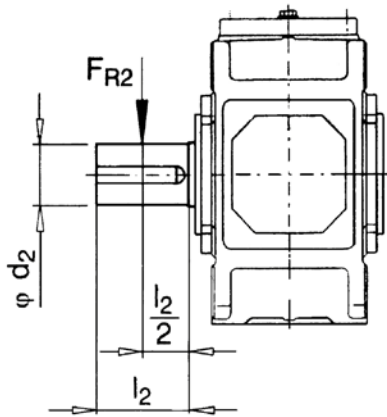

允许的作用力方向
Permissible direction of force

表 1/ Table 1

允许的附加径向力 F_{R2} (kN)，作用在输出轴轴伸中部³⁾

Permissible additional radial forces F_{R2} in kN with application of force on centre of shaft end³⁾

类型 Type	布置形式 Design	齿轮箱规格 / Gear unit sizes 1) 4)																	
		3	4	5	6	7	8	9	10	11	12	13	14	15	16	17	18		
P1SH	A/B	2)	—	2)	—	2)	—	2)	—	2)	—	2)	—	2)	—	2)	—		
P2S.	A/B/G/H	—	10	22	22	30	30	30	45	64	64	150	150	140	205	205	205		
	C/D	—	10	13	13	18	18	10	28	35	35	112	112	85	135	135	135		
V2S	A/C	—	13	27	27	37	37	38	55	78	78	160	160	150	210	210	210		
	B/D	—	12	15	15	17	17	10	30	35	38	110	110	75	145	100	100		
P3S.	A/B/G/H	—	—	29	29	40	40	40	60	85	85	190	190	185	265	265	265		
P4S.	C/D	—	—	—	—														
V3S.	A/C	—	14	29	29														
V4S.	A/C	—	—	18	18	26	26	18	40	50	50	150	150	120	185	185	190		
P3S.	C/D	—	—															18	18
P4S.	A/B	—	—															—	—
V3S.	B/D	—	9	18	18	26	26	18	40	50	50	150	150	120	185	185	190		
V4S.	B/D	—	—																

齿轮箱

在输出轴 $d_2^{1)}$ 上允许的

附加径向力

实心轴 (S)

Gear Units

Permissible Additional Radial

Forces on Output Shaft $d_2^{1)}$

Solid Shaft (S)

作用力不在轴身中部

Application of force outside the center of the shaft end

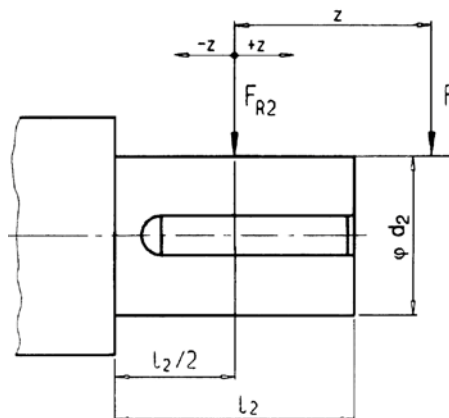

$$FRZ2 = FR2 \times k$$

FRZ2 允许的外部径向力

Permissible external radial force

FR2 允许的附加径向力, 根据第58页上的表1确定

Permissible additional radial force acc. To able 1 page 58

k 作用力系数根据下表确定

Factor application of force acc. To able

表2/Table 2

作用力系数k/Factor of application of force k

规格 Size	距离z.mm/ Distance z in mm														
	-200	-150	-100	-75	-50	-25	0	25	50	75	100	150	200	250	300
3					1.21	1.09	1.00	0.85	0.74	0.65	0.58	0.48			
4					1.17	1.08	1.00	0.86	0.76	0.68	0.62	0.52	0.44		
5+6				1.22	1.14	1.06	1.00	0.88	0.79	0.72	0.66	0.56	0.49	0.43	
7+8				1.19	1.12	1.06	1.00	0.89	0.81	0.74	0.68	0.58	0.51	0.46	0.41
9+10			1.22	1.15	1.10	1.05	1.00	0.90	0.82	0.76	0.70	0.61	0.54	0.48	0.44
11+12			1.18	1.13	1.08	1.04	1.00	0.91	0.84	0.78	0.73	0.64	0.57	0.51	0.47
13+14		1.24	1.15	1.11	1.07	1.03	1.00	0.92	0.86	0.80	0.75	0.67	0.60	0.55	0.50
15+16		1.20	1.12	1.09	1.06	1.03	1.00	0.93	0.87	0.82	0.77	0.69	0.63	0.58	0.53
17+18	1.25	1.17	1.11	1.08	1.05	1.03	1.00	0.94	0.88	0.84	0.79	0.72	0.66	0.60	0.56

1) 表中数值为最小值, 在 $f_1 \geq 1.2$ 时可以满足要求, 如果给出了力的作用角和旋转方向, 则在绝大多数情况下可以承受较大的附加力。

请与我们联系。

在必要时可以采用一个加强型输出轴 (V)

2) 敬请垂询

3) 当作用力不在轴伸中部时, 请参阅第59页

4) 地脚螺栓的最低性能等级为8.8, 基础必须干燥, 不得有油脂

敬请垂询:

- 输入轴 d_1 上允许的附加径向力

- 双出轴实心轴上允许的附加径向力 (设计形式E、F和I)

- 19-26号齿轮箱上允许的附加径向力

1) Values in tables are minimum values. They are valid for $f_1 \geq 1.2$. If the angel of application of force and the direction of rotation are given significantly higher additional forces can mostly be allowed.

Please contact us.

If necessary, a reinforced output shaft (V) can be used

2) On request

3) For application of force outside the centre of the shaft end, see page 59.

4) Use foundation bolts of min, property class 8.8. Foundation must be dry and grease-free

On request:

- Permissible additional radial forces on input shaft d_1

- Permissible additional radial forces on solid output shaft on both sides (assemblies E, F and I)

- Permissible additional radial forces for gear unit sizes 19-26

齿轮箱
装配形式

Gear Units
Assemblies

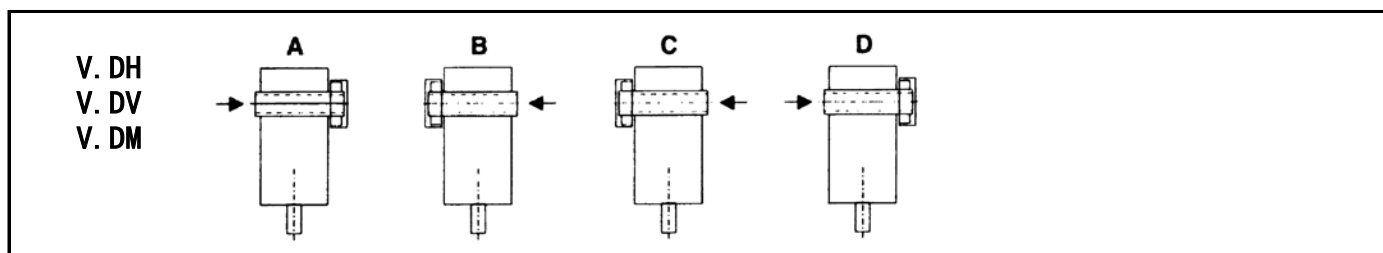
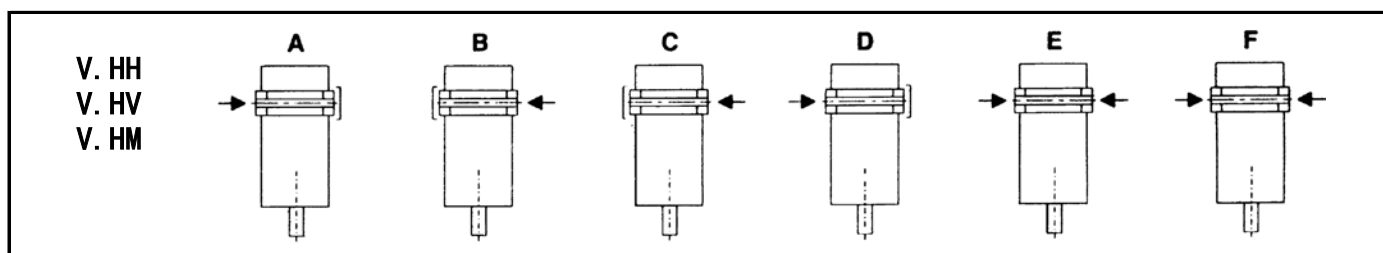
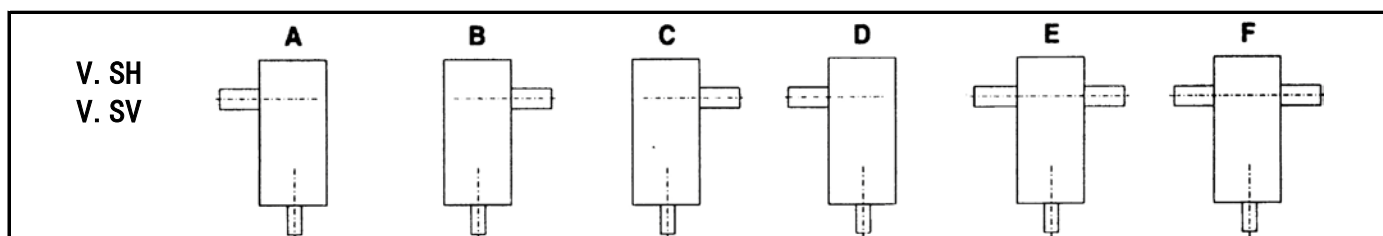
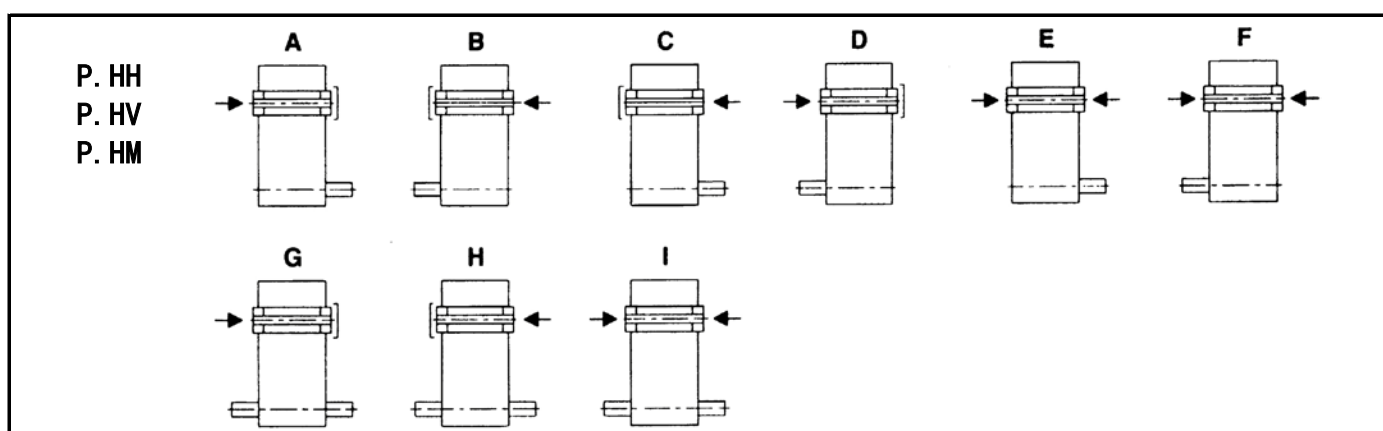
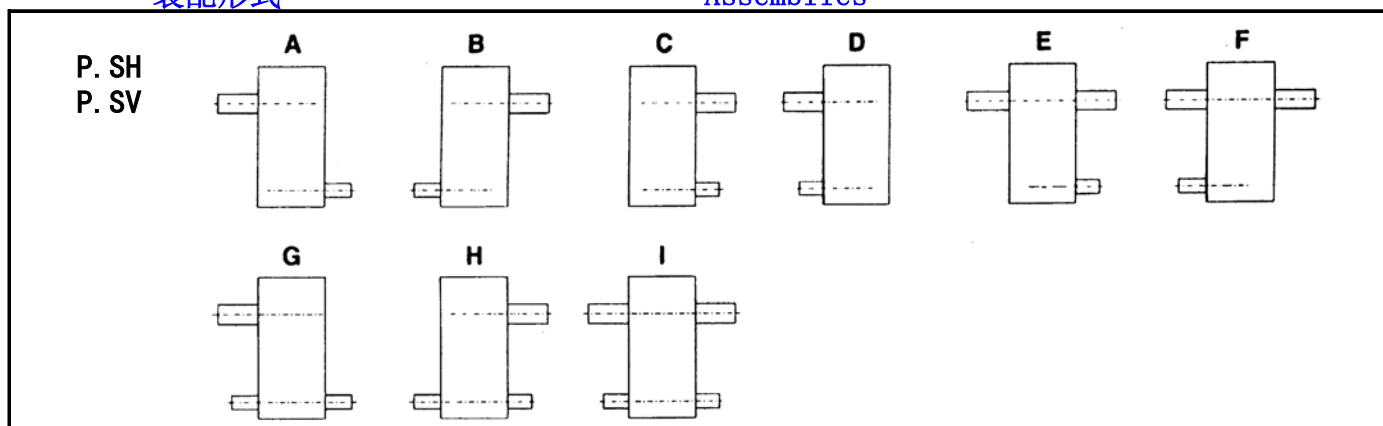

→箭头表示工作机驱动轴插入方向

→The arrow indicates the direction of insertion of the driven machine shaft

齿轮箱
单级传动
卧式安装
类型P1SH

Gear Units
Single stage
Horizontal
Type P1SH

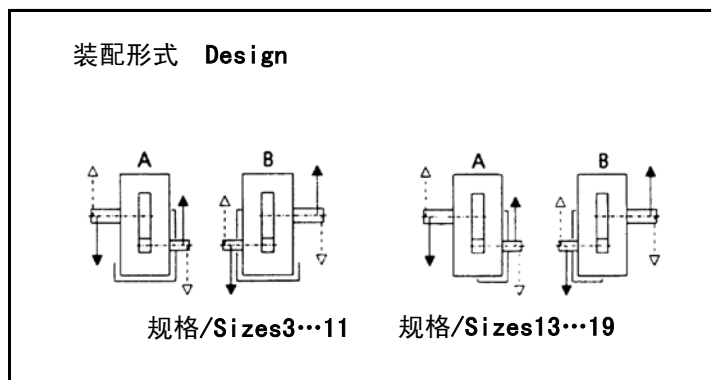
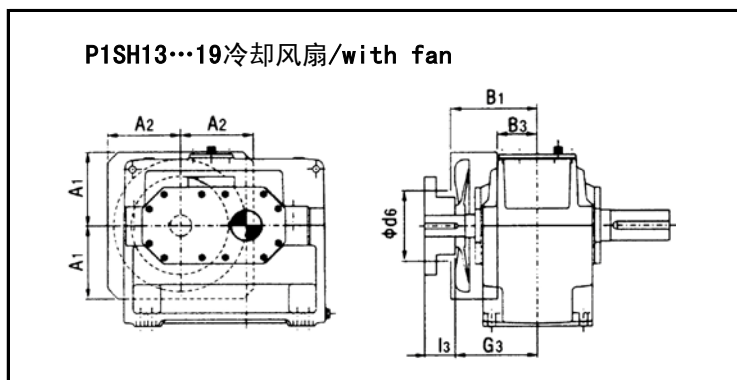
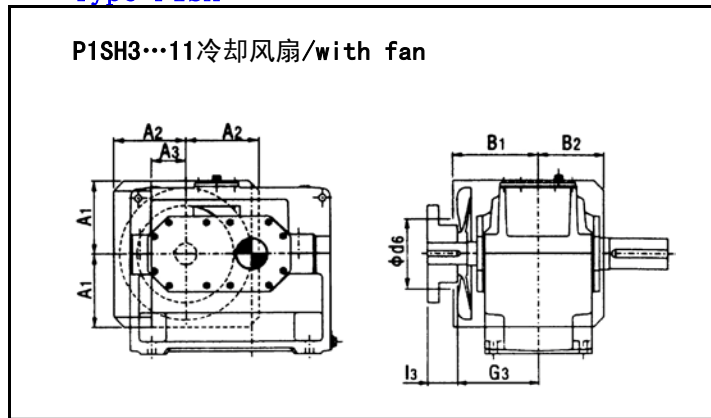
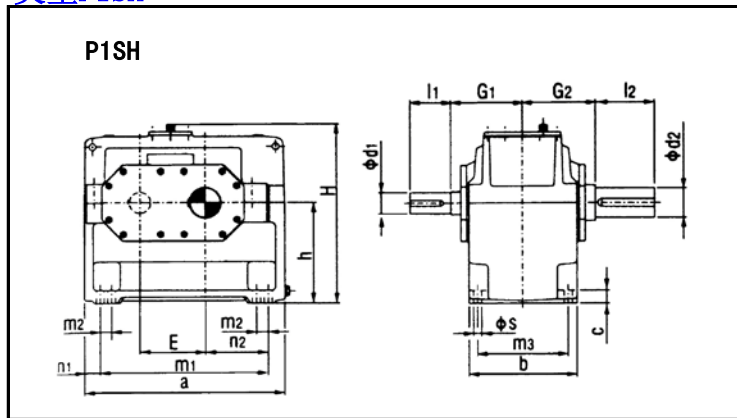

规格 Size	$i_N=1.25-2.8$			$i_N=1.6-2.8$			$i_N=2-2.8$			$i_N=3.15-4$			$i_N=4.5-5.6$			a	A1	A2	A3	b	B1	B2
	d1	l1	l3	d1	l1	l3	d1	l1	l3	d1	l1	l3	d1	l1	l3							
3	60m6	125	105							45m6	100	80	32m6	80	60	420	150	145	80	200	205	130
5	85m6	160	130							60m6	135	105	50m6	110	80	580	225	215	115	285	255	185
7	100m6	200	165							75m6	140	105	60m6	140	105	690	255	250	120	375	300	230
9	110m6	200	165							90m6	165	130	75m6	140	105	805	300	265	140	425	330	265
11				130m6	240	205				110m6	205	270	90m6	170	135	960	360	330	190	515	375	320
13				150m6	245	200				130m6	245	200	100m6	210	165	1100	415	350	-	580	430	-
15							180m6	290	240	150m6	250	200	125m6	250	200	1295	500	430	-	545	430	-
17							200m6	330	280	170m6	290	240	140m6	250	200	1410	550	430	-	615	470	-
19							220m6	240	290	190m6	340	290	160m6	300	250	1590	630	475	-	690	510	-

规格 Size	B3	c	d2	d6	E	G1	G2	G3	h°_1	H	l2	m1	m2	m3	n1	n2	s	润滑油oil (1) *		重量 weight (kg) *
																		(1) *	(2) *	
3	-	28	60m6	130	130	170	170	190	200	375	125	310	-	160	55	110	19	7	5.2	128
5	-	35	85m6	190	185	210	210	240	290	525	160	440	-	240	70	160	24	22	18	302
7	-	45	105m6	245	225	250	250	285	350	625	200	540	-	315	75	195	28	42	34	547
9	-	50	125m6	280	265	280	270	315	420	735	210	625	-	350	90	225	35	68	57	862
11	-	60	150m6	350	320	325	320	360	500	875	240	770	-	440	95	280	35	120	100	1515
13	150	70	180m6	350	370	365	360	410	580	1020	310	870	-	490	115	315	42	175	155	2395
15	120	80	220m6	450	442	360	360	410	600	1115	350	1025	-	450	135	370	48	190	156	3200
17	150	80	240m6	445	490	400	400	450	670	1235	400	1170	130	530	120	425	42	270	225	4250
19	190	90	270m6	445	555	440	440	490	760	1395	450	1290	150	590	150	465	48	390	330	5800

(1)* 轴封; (2)*迷宫式密封。

(1)* shaft seal (2)* labyrinth seal

齿轮箱

两级传动
卧式安装
类型P2.H
规格4-12

Gear Units

Two stage
Horizontal
Type P2.H
Sizes 4-12

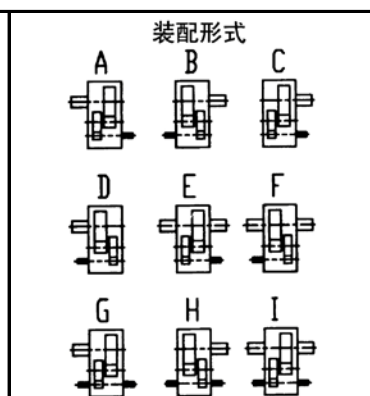
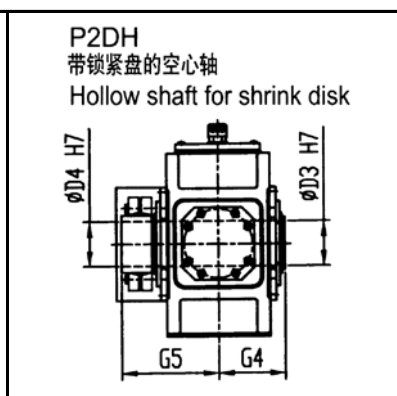
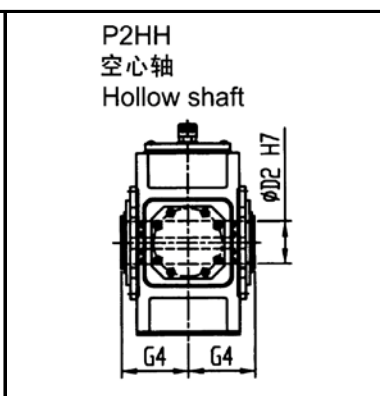
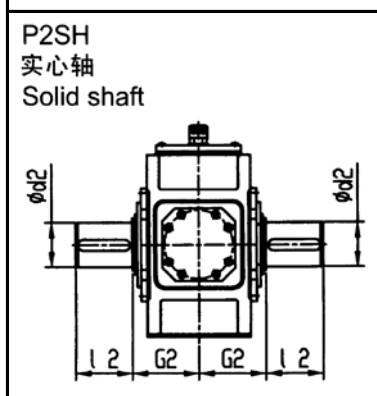
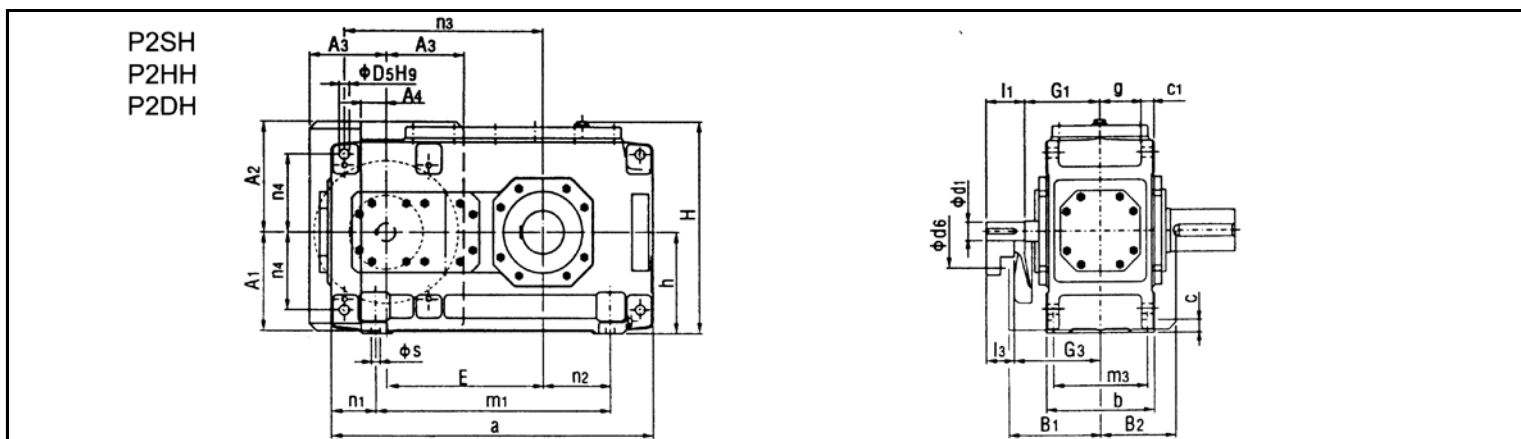

规格 Size	$i_N=6.3-11.2$			$i_N=8-14$			$i_N=12.5-22.4$			$i_N=16-28$			A1	A2	A3	A4	c1	c	B1	B2	a	b	d2	d6	D2	D3
	d1	l1	l3	d1	l1	l3	d1	l1	l3	d1	l1	l3														
4	45m6	100	80				32m6	80	60				195	225	150	30	30±1	28	205	158	565	215	80m6	136	80	85
5	50m6	100	80				38m6	80	60				225	260	175	55	30±1	28	230	178	640	255	100m6	150	95	100
6				50m6	100	80				38m6	80	60	225	260	175	55	30±1	28	230	178	720	255	110m6	150	105	110
7	60m6	135	105				50m6	110	80				272	305	210	70	36±1	35	255	210	785	300	120m6	200	115	120
8				60m6	135	105				50m6	110	80	272	305	210	70	36±1	35	255	210	890	300	130m6	200	125	130
9	75m6	140	110				60m6	140	110				312	355	240	100	45±1.5	40	285	245	925	370	140m6	200	135	145
10				75m6	140	110				60m6	140	110	312	355	240	100	45±1.5	40	285	245	1025	370	160m6	200	150	155
11	90m6	165	130				70m6	140	105				372	420	285	135	54±1.5	50	325	285	1105	430	170m6	210	165	170
12				90m6	165	130				70m6	140	105	372	420	285	135	54±1.5	50	325	285	1260	430	180m6	210	180	185

规格 Size	D4	D5	E	g	G1	G2	G3	G4	G5	h°_{-1}	H	l2	m1	m3	n1	n2	n3	n4	s	润滑油oil (1) *		重量 weight (kg) *
																				(1) *	(2) *	
																				(1) *	(2) *	
4	85	24	270	77.5	170	140	190	140	205	200	415	170	355	180	105	85	345	150	19	10	7	190
5	100	24	315	97.5	195	165	215	165	240	230	482	210	430	220	105	100	405	180	19	15	11	300
6	110	24	350	97.5	195	165	215	165	240	230	482	210	510	220	105	145	440	180	19	16	12	355
7	120	28	385	114	210	195	240	195	280	280	572	210	545	260	120	130	550	215	24	27	21	505
8	130	28	430	114	210	195	240	195	285	280	582	250	650	260	120	190	545	215	24	30	23	590
9	140	36	450	140	240	235	270	235	330	320	662	250	635	320	145	155	585	245	28	42	33	830
10	150	36	500	140	240	235	270	235	350	320	662	300	735	320	145	205	635	245	28	45	34	960
11	165	40	545	161	275	270	310	270	400	380	782	300	775	370	165	180	710	300	35	71	58	1335
12	180	40	615	161	275	270	310	270	405	380	790	300	930	370	165	265	780	300	35	76	60	1615

(1)* 轴封; (2)* 迷宫式密封。

(1)* shaft seal (2)* labyrinth seal

齿轮箱
两级传动
卧式安装
类型 P2. H, P2. M
规格 13-26

Gear Units
Two stage
Horizontal
Type P2. H, P2. M
Sizes 13-26

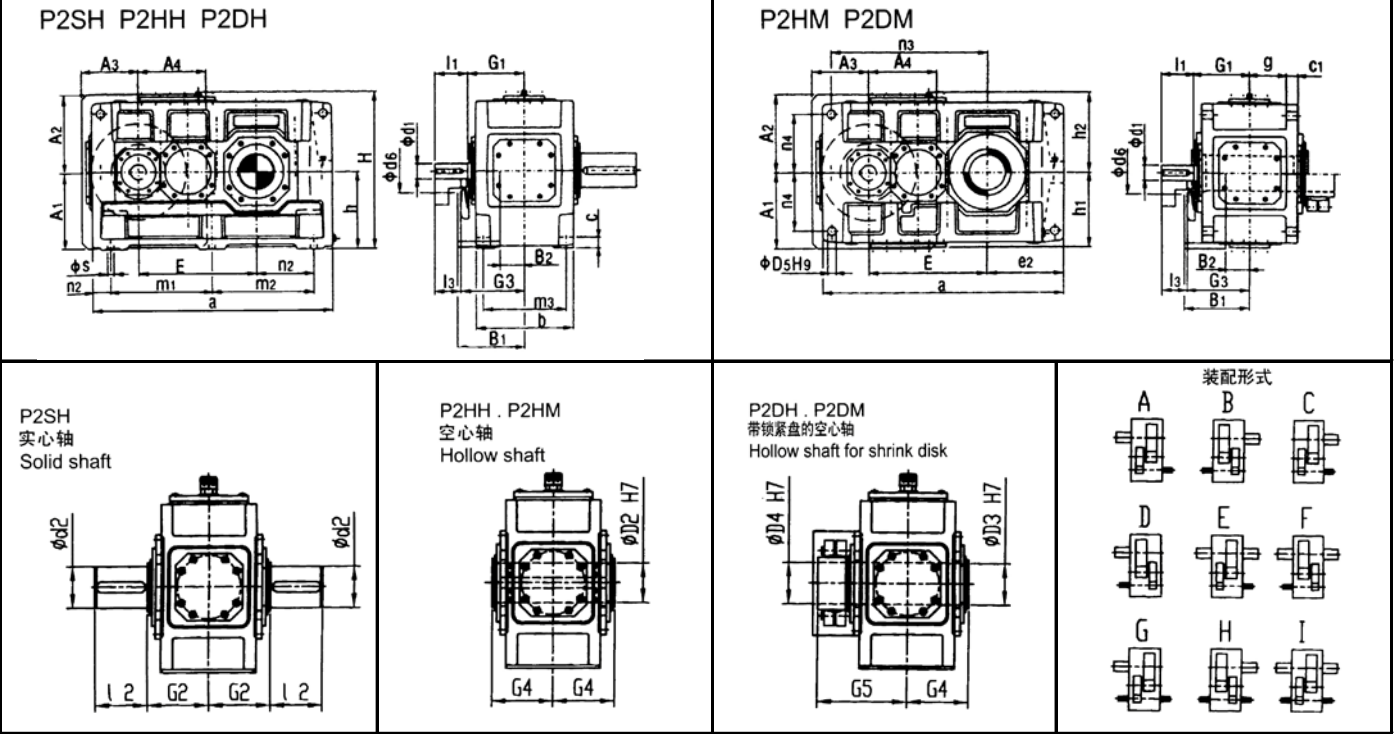

规格 Size	$i_N=6.3-11.2$			$i_N=7.1-12.5$			$i_N=8-14$			$i_N=12.5-20$			$i_N=14-22.4$			$i_N=16-25$			a	A1	A2	A3	A4	b	B1	B2	c	c1	d2	d6	D2	D3	
	d1	l1	l3	d1	l1	l3	d1	l1	l3	d1	l1	l3	d1	l1	l3	d1	l1	l3															
13	100m6	205	170							85m6	170	135								1290	430	460	330	365	550	385	135	60	61±2	200n6	250	190	195
14										100m6	205	170								1430	430	460	330	365	550	385	135	60	61±2	210n6	250	210	215
15	120n6	210	165							100m6	210	165								1550	490	500	370	440	625	430	155	70	72±2	230n6	280	230	235
16				120n6	210	165				100m6	210	165								1640	490	500	370	440	625	430	155	70	72±2	240n6	280	240	245
17	125n6	245	200							110n6	210	165								1740	540	565	435	505	690	485	140	80	81±2	250n6	280	250	260
18				125n6	245	200				110n6	210	165								1860	540	565	435	505	690	485	140	80	81±2	270n6	280	275	285
19	150n6	245	200							120n6	210	165								2010	600	600	500	450	790	540	190	90	91±2	290n6	310	-	295
20				150n6	245	200				120n6	210	165								2130	600	600	500	450	790	540	190	90	91±2	300n6	310	-	315
21	170n6	290	240							140n6	250	200								2140	680	680	500	610	830	565	200	100	100±2	320n6	450	-	335
22				170n6	290	240				140n6	250	200								2250	680	680	500	610	830	565	200	100	100±2	340n6	450	-	345
23	190n6	330	280							150n6	250	200								2380	770	770	550	550	930	630	220	115	20±2	360n6	450	-	365
24				190n6	330	280				150n6	250	200								2510	770	770	550	550	930	630	220	115	20±2	380n6	450	-	385
25	200n6	340	290							170n6	300	250								2580	845	865	550	550	1045	670	240	130	20±2	400n6	450	-	405
26				200n6	340	290				170n6	300	250								2760	845	865	550	550	1045	670	240	130	20±2	420n6	450	-	435

规格 Size	D4	D5	e2	E	g	G1	G2	G3	G4	G5	h* -1	h1	h2	H	12	m1	m2	m3	n1	n2	n3	n4	s	润滑油oil (1)			重量 weight (kg)	
																								H2. H		H2. M	H2. H	H2. M
																								(1) *	(2) *			
13	190	48	405	635	####	330	335	365	335	480	440	450	460	900	350	545	545	475	100	305	835	340	35	135	120	110	2000	1880
14	210	48	475	705	####	330	335	365	335	480	440	450	460	900	350	545	685	475	100	375	905	340	35	140	130	115	2570	2430
15	230	55	485	762	238	365	380	410	380	550	500	490	500	1000	410	655	655	535	120	365	1005	375	42	210	190	160	3430	3240
16	240	55	530	808	238	365	380	410	380	550	500	490	500	1000	410	655	745	535	120	410	1050	375	42	215	200	165	3655	3465
17	250	55	525	860	259	420	415	465	415	600	550	555	560	1110	410	735	735	600	135	390	1145	425	42	290	260	230	4650	4420
18	280	55	585	920	259	420	415	465	415	600	550	555	560	1110	470	735	855	600	135	450	1205	425	42	300	270	240	5125	4870
19	285	65	590	997	299	475	465	520	465	670	620	615	620	1240	470	850	850	690	155	435	1345	475	48	320	-	300	6600	6300
20	310	65	650	1057	299	475	465	520	465	670	620	615	620	1240	500	850	970	690	155	495	1405	475	48	340	-	320	7500	7200
21	330	75	655	1067	310	495	490	545	490	715	700	685	690	1390	500	900	900	720	170	485	1400	520	56	320	-	350	8900	8400
22	340	75	710	1122	310	495	490	545	490	725	700	685	690	1390	550	900	1010	720	170	540	1455	520	56	340	-	370	9600	9200
23	360	80	730	1185	342	560	540	610	540	785	780	770	770	1550	590	1010	1010	810	180	550	1560	580	56	430	-	470	####	####
24	380	80	795	1250	342	560	540	610	540	805	780	770	770	1550	590	1010	1140	810	180	615	1625	580	56	450	-	500	####	####
25	400	90	790	1325	400	600	605	650	605	875	860	860	860	1720	650	1090	1090	910	200	590	1685	660	66	600	-	660	####	####
26	430	90	880	1415	400	600	605	650	605	900	860	860	860	1720	650	1090	1270	910	200	680	1775	660	66	640	-	700	####	####

(1)*轴封; (2)*迷宫式密封。

(1)*shaft seal; (2)*Labyrinth seal.

齿轮箱
 三级传动
 卧式安装
 类型 P3.H
 规格 5-12

Gear Units
 Three stage
 Horizontal
 Type P3.H
 Sizes 5-12

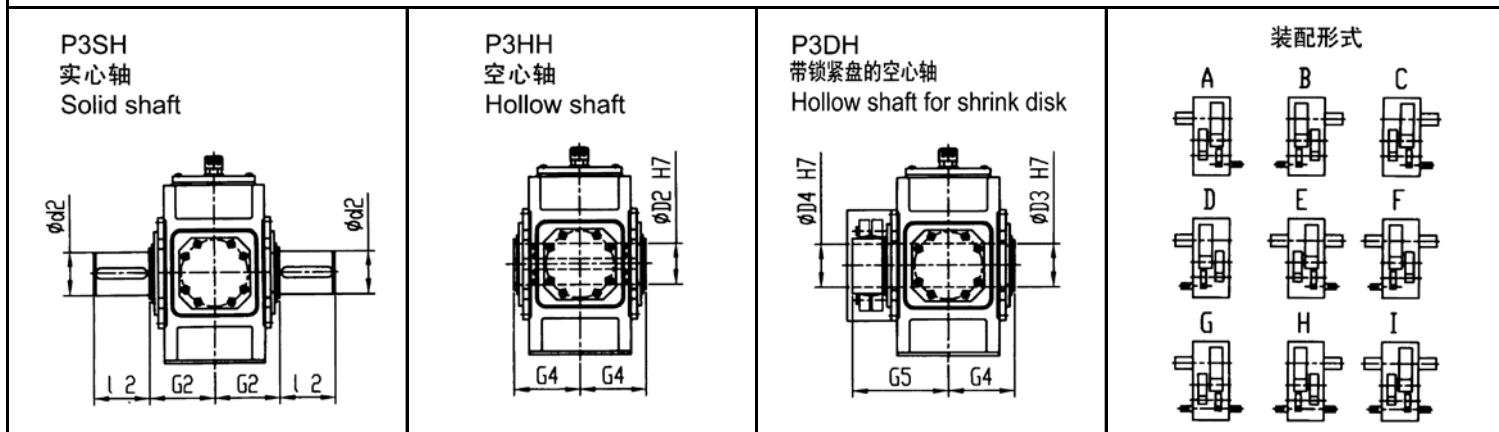
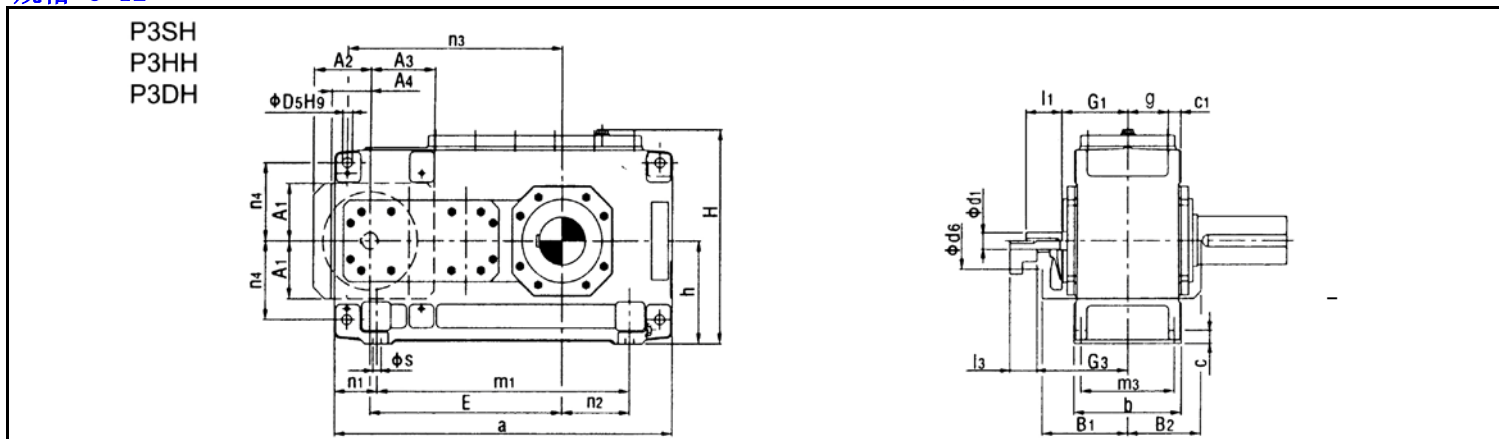

规格 Size	$i_N=25-45$			$i_N=31.5-56$			$i_N=50-63$			$i_N=63-80$			$i_N=71-90$			$i_N=90-112$			a	A4	A1	A2	A3	b	B1	B2	c1	c	d2
	d1	l1	l3	d1	l1	l3	d1	l1	l3	d1	l1	l3	d1	l1	l3	d1	l1	l3											
5	40m6	70	70				30m6	50	50				24k6	40	40				690	140	137	135	140	255	215	175	30±1	28	100m6
6				40m6	70	70				30m6	50	50				24k6	40	40	770	140	137	135	140	255	215	175	30±1	28	110m6
7	45m6	80	80				35m6	60	60				28m6	50	50				845	180	157	160	180	300	245	205	36±1	35	120m6
8				45m6	80	80				35m6	60	60				28m6	50	50	950	180	157	160	180	300	245	205	36±1	35	130m6
9	60m6	125	105				45m6	100	80				32m6	80	60				1000	205	182	190	205	370	295	240	5±1	40	140m6
10				60m6	125	105				45m6	100	80				32m6	80	60	1100	205	182	190	205	370	295	240	5±1	40	160m6
11	70m6	120	120				50m6	80	80				42m6	70	70				1200	255	218	220	255	430	325	280	4±1	50	170m6
12				70m6	120	120				50m6	80	80				42m6	70	70	1355	255	218	220	255	430	325	280	4±1	50	180n6

规格 Size	d6	D2	D3	D4	D5	E	g	G1	G2	G3	G4	G5	$h^\circ -1$	H	12	m1	m3	n1	n2	n3	n4	s	润滑油oil (l)	重量 weight (kg)
5	60	95	100	100	24	405	97.5	160	165	220	165	240	230	482	210	480	220	105	100	455	180	19	16	320
6	60	105	110	110	24	440	97.5	160	165	220	165	240	230	482	210	560	220	105	145	490	180	19	18	365
7	75	115	120	120	28	495	114	185	195	250	195	280	280	572	210	605	260	120	130	560	215	24	29	540
8	75	125	130	130	28	540	114	185	195	250	195	285	280	582	250	710	260	120	190	605	215	24	32	625
9	90	135	145	140	36	580	140	230	235	300	235	330	320	662	250	710	320	145	155	660	245	28	48	875
10	90	150	155	150	36	630	140	230	235	300	235	350	320	662	300	810	320	145	205	710	245	28	49	1020
11	100	165	170	165	40	705	161	255	270	330	270	400	380	782	300	870	370	165	180	805	300	35	85	1400
12	100	180	185	180	40	775	161	255	270	330	270	405	380	790	300	1025	370	165	265	875	300	35	90	1675

齿轮箱
三级传动
卧式安装
类型 P3. H, P3. M
规格 13-26

Gear Units
Three stage
Horizontal
Type P3. H, P3. M
Sizes 13-26

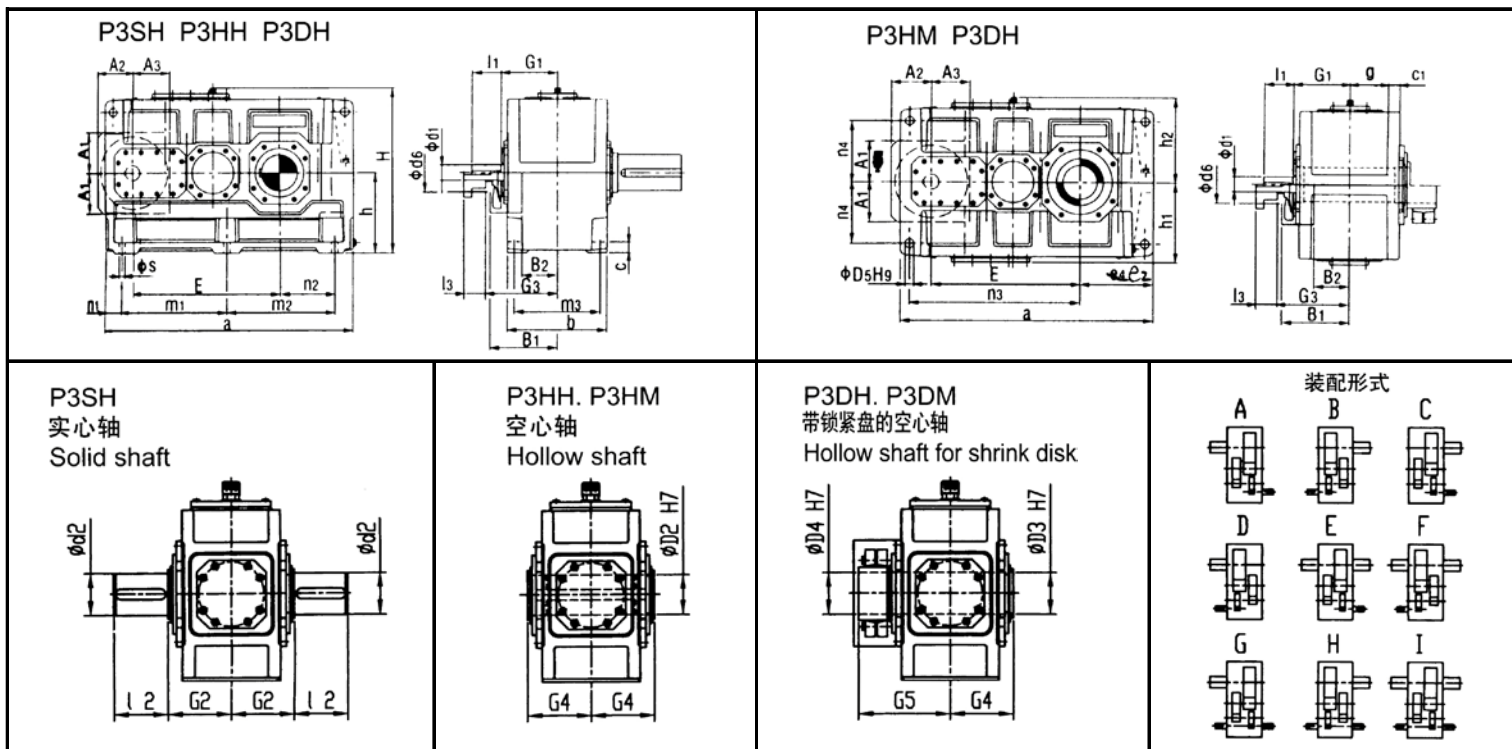

规格 Size	$i_N=22.4-45$			$i_N=25-50$			$i_N=50-63$			$i_N=56-71$			$i_N=71-90$			$i_N=80-100$			a	A1	A2	A3	b	B1	B2	c	c1	d2	d6	D2	D3
	d1	l1	l3	d1	l1	l3	d1	l1	l3	d1	l1	l3	d1	l1	l3	d1	l1	l3													
13	85m6	160	130				60m6	135	105				50m6	110	80				1395	225	225	212	550	380	195	60	61±2	200n6	120	190	195
14				$i_N=28-56$						$i_N=63-80$						$i_N=90-112$			1535	225	225	212	550	380	195	60	61±2	210n6	120	210	215
15	100m6	200	165				75m6	140	105				60m6	140	105				1680	270	265	252	625	415	205	70	72±2	230n6	150	230	235
16				100m6	200	165				75m6	140	105				60m6	140	105	1770	270	265	252	625	415	205	70	72±2	240n6	150	240	245
17	100m6	200	165				75m6	140	105				60m6	140	105				1770	270	265	252	690	445	235	80	81±2	250n6	150	250	260
18				100m6	200	165				75m6	140	105				60m6	140	105	1890	270	265	252	690	445	235	80	81±2	270n6	150	275	285
19	110n6	200	*				90m6	165	*				75m6	140	*				2030	*	*	*	790	*	*	90	91±2	290n6	*	-	295
20				110n6	200	*				90m6	165	*				75m6	140	*	2150	*	*	*	790	*	*	90	91±2	300n6	*	-	315
21	130n6	240	*				110n6	205	*				90m6	170	*				2340	*	*	*	830	*	*	100	100±2	320n6	*	-	335
22				130n6	240	*				110n6	205	*				90m6	170	*	2450	*	*	*	830	*	*	100	100±2	340n6	*	-	345
23	130n6	240	-				110n6	205	-				90m6	170	-				2530	-	-	-	930	-	-	115	120±2	360n6	-	-	365
24				130n6	240	-				110n6	205	-				90m6	170	-	2660	-	-	-	930	-	-	115	120±2	380n6	-	-	385
25	150n6	245	-				130n6	245	-				100m6	210	-				2830	-	-	-	1045	-	-	130	120±2	400n6	-	-	405
26				150n6	245	-				130n6	245	-				100m6	210	-	3010	-	-	-	1045	-	-	130	120±2	420n6	-	-	435

规格 Size	D4	D5	e2	E	g	G1	G2	G3	G4	G5	h° -1	h1	h2	H	12	m1	m2	m3	n1	n2	n3	n4	s	润滑油oil(1)		重量weight (kg)	
																								H3. H	H3. M	H3. H	H3. M
13	190	48	405	820	211.5	310	335	385	335	480	440	450	460	900	350	597.5	597.5	475	100	305	940	340	35	160	125	2295	2155
14	210	48	475	890	211.5	310	335	385	335	480	440	450	460	900	350	597.5	737.5	475	100	375	1010	340	35	165	130	2625	2490
15	230	55	485	987	238	350	380	420	380	550	500	490	500	1000	410	720	720	535	120	365	1135	375	42	235	190	3475	3260
16	240	55	530	1033	238	350	380	420	380	550	500	490	500	1000	410	720	810	535	120	410	1180	375	42	245	195	3875	3625
17	250	55	525	1035	259	380	415	450	415	600	550	555	560	1110	410	750	750	600	135	390	1175	425	42	305	240	4560	4250
18	280	55	585	1095	259	380	415	450	415	600	550	555	560	1110	470	750	870	600	135	450	1235	425	42	315	250	5030	4740
19	285	65	590	1190	299	430	465	*	465	670	620	615	620	1240	470	860	860	690	155	435	1365	475	48	420	390	6700	6200
20	310	65	650	1250	299	430	465	*	465	670	620	615	620	1240	500	860	980	690	155	495	1425	475	48	450	415	8100	7600
21	330	75	655	1387	310	470	490	*	490	715	700	685	690	1390	500	1000	1000	720	170	485	1600	520	56	470	515	9100	8500
22	340	75	710	1442	310	470	490	*	490	725	700	685	690	1390	550	1000	1110	720	170	540	1655	520	56	490	540	9800	9300
23	360	80	730	1505	342	510	540	-	540	785	780	770	790	1570	590	1085	1085	810	180	550	1725	580	56	620	690	####	####
24	380	80	795	1570	342	510	540	-	540	805	780	770	790	1570	590	1085	1215	810	180	615	1790	580	56	650	725	####	####
25	400	90	790	1695	400	570	605	-	605	875	860	860	860	1720	650	1215	1215	910	200	590	1965	660	66	880	970	####	####
26	430	90	880	1785	400	570	605	-	605	900	860	860	860	1720	650	1215	1395	910	200	680	2055	660	66	935	1030	####	####

注：“*”按客户要求供货

Note: * ON request.

齿轮箱
四级传动
卧式安装
类型 P4. H
规格 7-12

Gear Units
Four stage
Horizontal
Type P4. H
Sizes 7-12

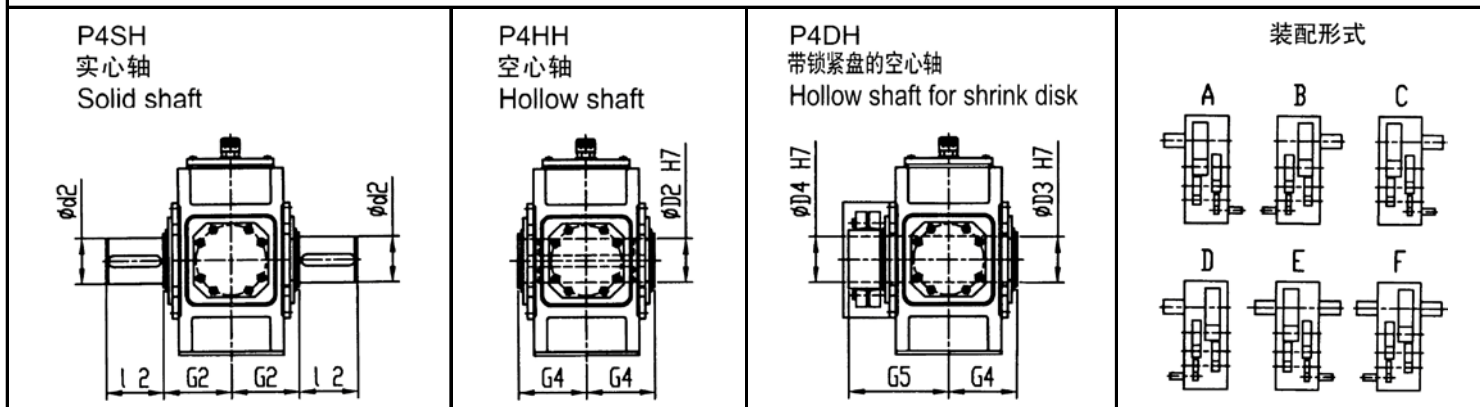
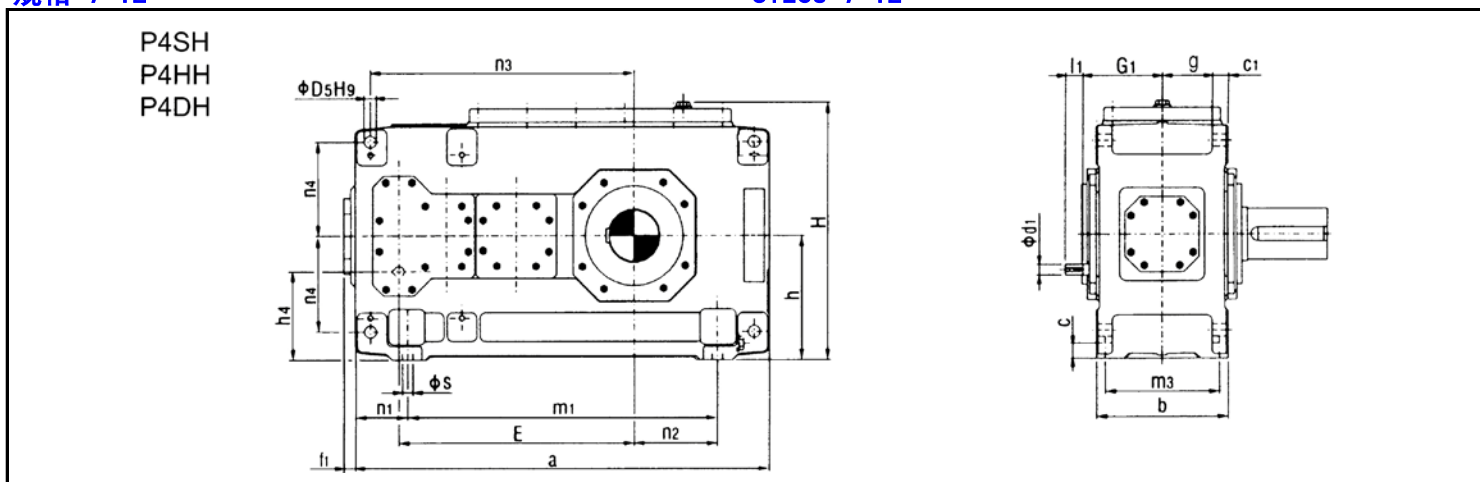

规格 Size	$i_N=100-180$		$i_N=125-224$		$i_N=200-355$		$i_N=250-450$		a	b	c	c1	d2	D2	D3	D4	D5	E
	d1	l1	d1	l1	d1	l1	d1	l1										
7	30m6	50			24k6	40			845	300	35	36 ± 1	120n6	115	120	120	28	495
8			30m6	50			24k6	40	950	300	35	36 ± 1	130n6	125	130	130	28	540
9	35m6	60			28m6	50			1000	370	40	45 ± 1.5	140n6	135	145	140	36	580
10			35m6	60			28m6	50	1100	370	40	45 ± 1.5	160n6	150	150	150	36	630
11	45m6	100			32m6	80			1200	430	50	54 ± 1.5	170n6	165	165	165	40	705
12			45m6	100			32m6	80	1355	430	50	54 ± 1.5	180n6	180	180	180	40	775

规格 Size	f1	g	G1	G2	G4	G5	$h^{\circ} -1$	h4	H	l2	m1	m3	n1	n2	n3	n4	s	润滑油 oil (l)	重量 weight (kg)
7	37	114	180	195	195	280	280	200	572	210	605	260	120	130	560	215	24	25	550
8	37	114	180	195	195	285	280	200	582	250	710	260	120	190	605	215	24	27	645
9	43	140	215	235	235	330	320	230	662	250	710	320	145	155	660	245	28	48	875
10	43	140	215	235	235	350	320	230	662	300	810	320	145	205	710	245	28	50	1010
11	47	161	250	270	270	400	380	270	782	300	870	370	165	180	805	300	35	80	1460
12	47	161	250	270	270	405	380	270	790	300	1025	370	165	265	875	300	35	87	1725

齿轮箱
四级传动
卧式安装
类型P4. H. P4. M
规格 13-26

Gear Units
Four stage
Horizontal
Type P4. H. P4. M
Sizes 13-26

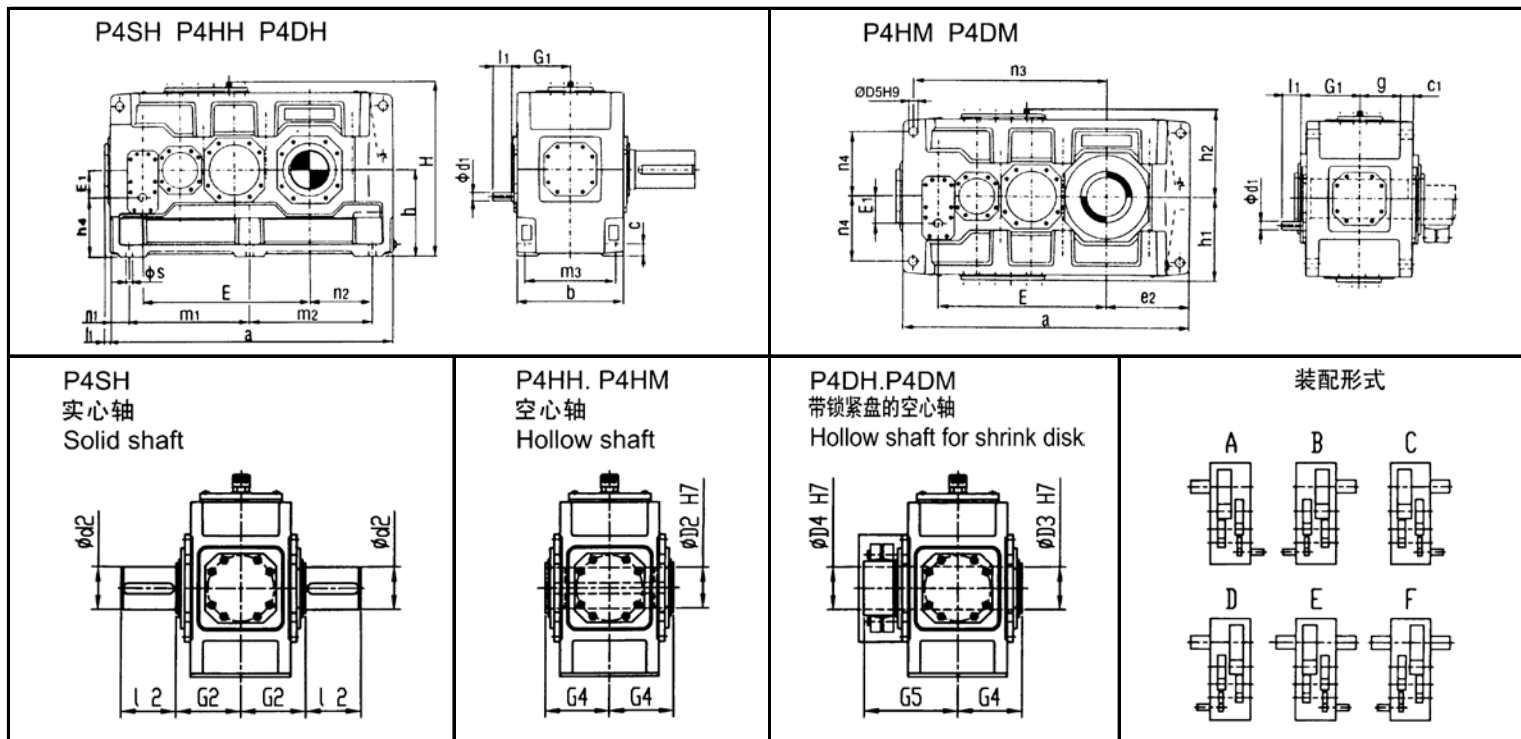

规格 Size	$i_N=100-180$		$i_N=112-200$		$i_N=125-22$		$i_N=200-355$		$i_N=224-400$		$i_N=250-450$		a	b	c	c1	d2	D2	D3	D4	D5	e2	E	E1
	d1	l1	d1	l1	d1	l1	d1	l1	d1	l1	d1	l1												
13	50m6	100					38m6	80					1395	550	60	61±2	200m6	190	195	190	48	405	820	130
14					50m6	100					38m6	80	1535	550	60	61±2	210m6	210	215	210	48	475	890	130
15	60m6	135					50m6	110					1680	625	70	72±2	230m6	230	235	230	55	485	987	160
16			60m6	135				50m6	110				1770	625	70	72±2	240m6	240	245	240	55	530	1033	160
17	60m6	105					50m6	80					1770	690	80	81±2	250m6	250	260	250	55	525	1035	160
18			60m6	105				50m6	80				1890	690	80	81±2	270m6	275	285	280	55	585	1095	160
19	75m6	105					60m6	105					2030	790	90	91±2	290m6	-	295	285	65	590	1190	185
20			75m6	105				60m6	105				2150	790	90	91±2	300m6	-	315	310	65	650	1250	185
21	90m6	165					70m6	140					2340	830	100	100±2	320m6	-	335	330	75	655	1387	225
22			90m6	165				70m6	140				2450	830	100	100±2	340m6	-	345	340	75	710	1442	225
23	90m6	130					70m6	105					2530	930	115	120±2	360m6	-	365	360	80	730	1505	225
24			90m6	130				70m6	105				2660	930	115	120±2	380m6	-	385	380	80	795	1570	225
25	100m6	205					85m6	170					2830	1045	130	120±2	400m6	-	405	400	90	790	1695	265
26			100m6	205				85m6	170				3010	1045	130	120±2	420m6	-	435	430	90	880	1785	265

规格 Size	f1	g	G1	G2	G4	G5	$h^{\circ}-1$	h1	h2	h4	H	12	m1	m2	m3	n1	n2	n3	n4	s	润滑油oil (l) *		重量weight (kg)	
																					H4. H	H4. M	H4. H	H4. M
13	47	212	335	335	335	480	440	450	440	310	900	350	597.5	598	475	100	305	940	340	35	130	120	2390	2270
14	47	212	335	335	335	480	440	450	440	310	900	350	597.5	598	475	100	375	1010	340	35	140	125	2730	2600
15	56	238	345	380	380	550	500	490	500	340	1000	410	720	720	535	120	365	1135	375	42	230	170	3635	3440
16	56	238	345	380	380	550	500	490	500	340	1000	410	720	810	535	120	410	1180	375	42	235	175	3965	3740
17	53	259	380	415	415	600	550	555	550	390	1110	410	750	750	600	135	390	1175	425	42	290	225	4680	4445
18	53	259	380	415	415	600	550	555	550	390	1110	470	750	870	600	135	450	1235	425	42	305	230	5185	4915
19	53	299	440	465	-	670	620	615	620	435	1240	470	860	860	690	155	435	1365	475	48	430	310	6800	6300
20	53	299	440	465	-	670	620	615	620	435	1240	500	860	980	690	155	495	1425	475	48	380	330	8200	7700
21	62	310	460	490	-	715	700	685	690	475	1390	500	1000	1000	720	170	485	1600	520	56	395	430	9200	8600
22	62	310	460	490	-	725	700	685	690	475	1390	550	1000	1110	720	170	540	1655	520	56	420	450	9900	9400
23	35	342	505	540	-	785	780	770	790	555	1570	590	1085	1085	810	180	550	1725	580	56	520	500	11600	10700
24	35	342	505	540	-	805	780	770	790	555	1570	590	1085	1215	810	180	615	1790	580	56	550	600	13500	12600
25	65	400	565	605	-	875	860	860	860	595	1720	650	1215	1215	910	200	590	1965	660	66	735	800	16100	15200
26	65	400	565	605	-	900	860	860	860	595	1720	650	1215	1395	910	200	680	2055	660	66	780	850	17600	16500

齿轮箱

两级传动
卧式安装
类型V2.H
规格4-12

Gear Units

Two stage
Horizontal
Type V2.H
Sizes 4-12

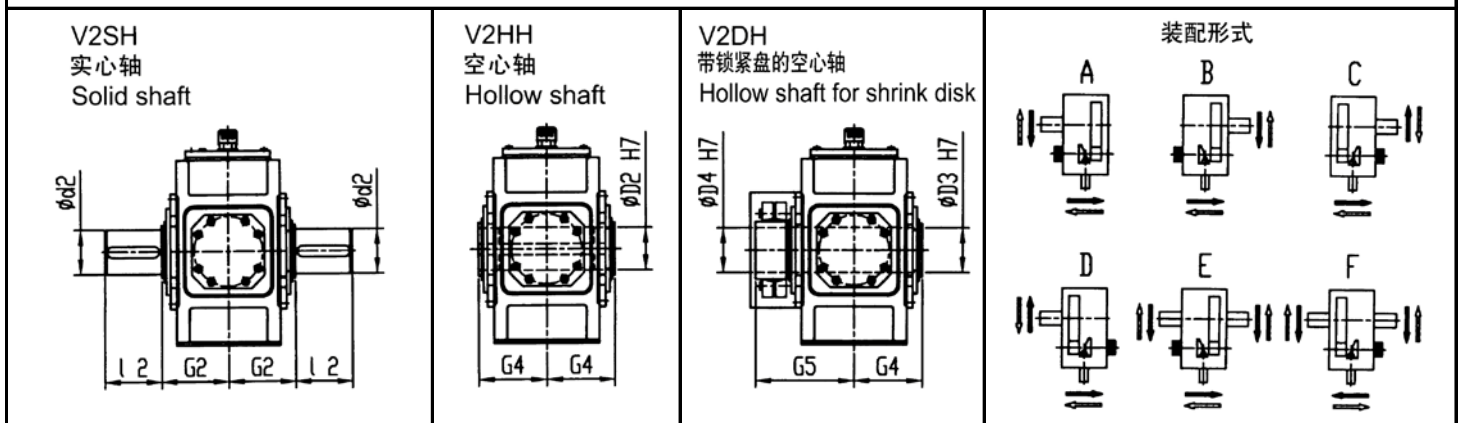
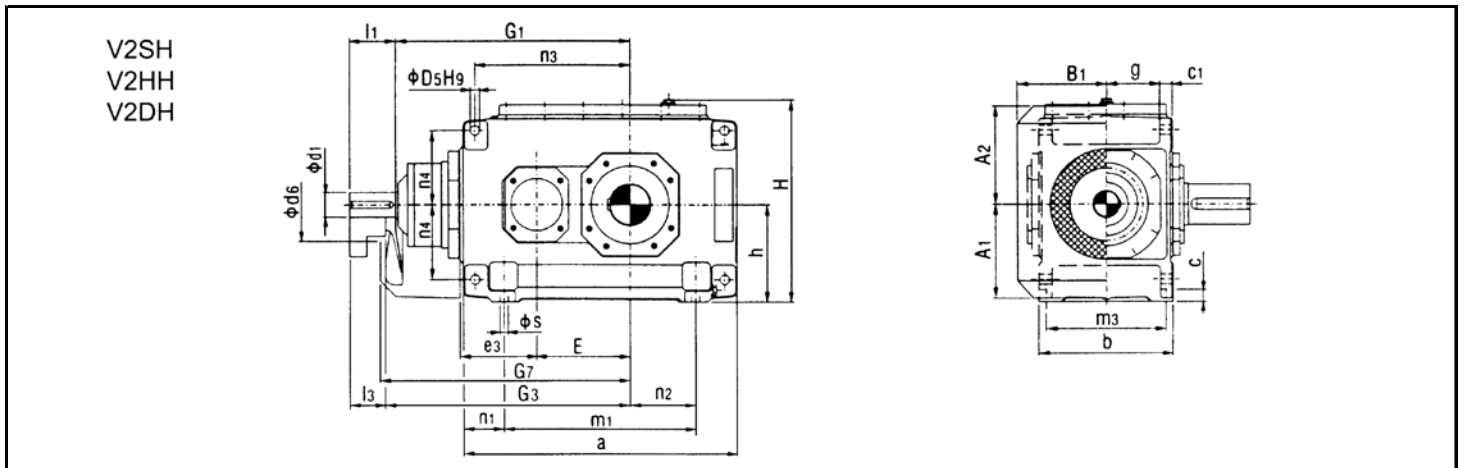

规格 Size	$i_N=5-11.2$			$i_N=6.3-14$			a	A1	A2	b	B1	c	c1	d2	d6	D2	D3	D5	e3	E
	d1	l1	l3	d1	l1	l3														
4	45m6	110	80				505	195	200	270	188	28	30±1	80m6	150	80	85	24	160	160
5	55m6	110	80				565	220	235	320	215	28	30±1	100m6	160	95	100	4	185	185
6				55m6	110	80	645	220	235	320	215	28	30±1	110m6	160	105	110	24	185	220
7	70m6	135	105				690	270	285	380	250	35	36±1	120m6	210	115	120	28	225	225
8				70m6	135	105	795	270	285	380	250	35	36±1	130m6	210	125	130	28	225	270
9	80m6	165	130				820	310	325	440	270	40	48±1.5	140m6	195	135	145	36	265	265
10				80m6	165	130	920	310	325	440	270	40	48±1.5	160m6	195	150	155	36	265	315
11	90m6	165	130				975	370	385	530	328	50	54±1.5	170m6	210	165	170	40	320	320
12				90m6	165	130	1130	370	385	530	328	50	54±1.5	180m6	210	180	185	40	320	390

规格 Size	g	G1	G2	G3	G4	G5	G7	h°_{-1}	H	l2	m1	m3	n1	n2	n3	n4	s	润滑油oil (1)*		重量 weight (kg)*
																		(1)*	(2)*	
4	105	465	170	485	170	235	495	200	415	170	295	235	105	85	285	150	19	10		235
5	130	535	200	565	200	275	575	230	482	210	355	285	105	100	330	180	19	16		360
6	130	570	200	600	200	275	610	230	482	210	435	285	105	145	365	180	19	19		410
7	154	640	235	670	235	320	685	280	582	210	450	340	120	130	405	215	24	31		615
8	154	685	235	715	235	325	730	280	582	250	555	340	120	190	450	215	24	34		700
9	172	755	270	790	270	365	805	320	662	250	530	390	145	155	480	245	28	48		1000
10	172	805	270	840	270	385	855	320	662	300	630	390	145	205	530	245	28	50		1155
11	211	925	320	960	320	450	980	380	790	300	645	470	165	180	580	300	35	80		1640
12	211	995	320	1030	320	455	1050	380	790	300	800	470	165	265	650	300	35	95		1910

(1)* 轴封; (2)*迷宮式密封。

(1)* shaft seal (2)* labyrinth seal

齿轮箱
三级传动
卧式安装
类型 V2. H V2. M
规格 13-18

Gear Units
Three stage
Horizontal
Type V2. H V2. M
Sizes 13-18

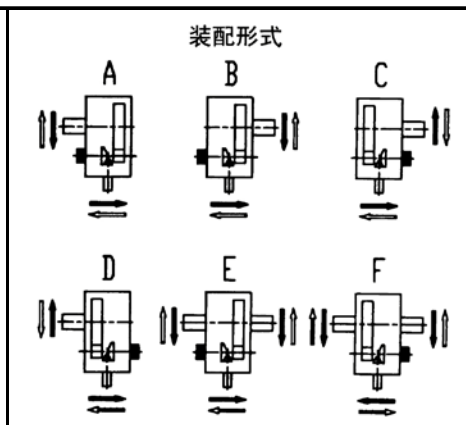
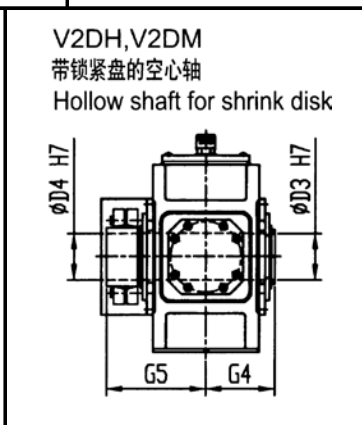
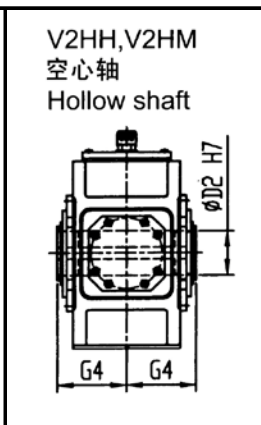
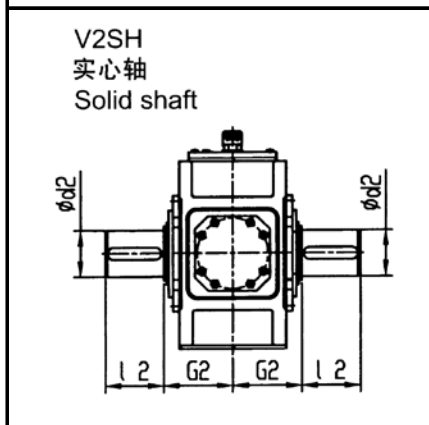
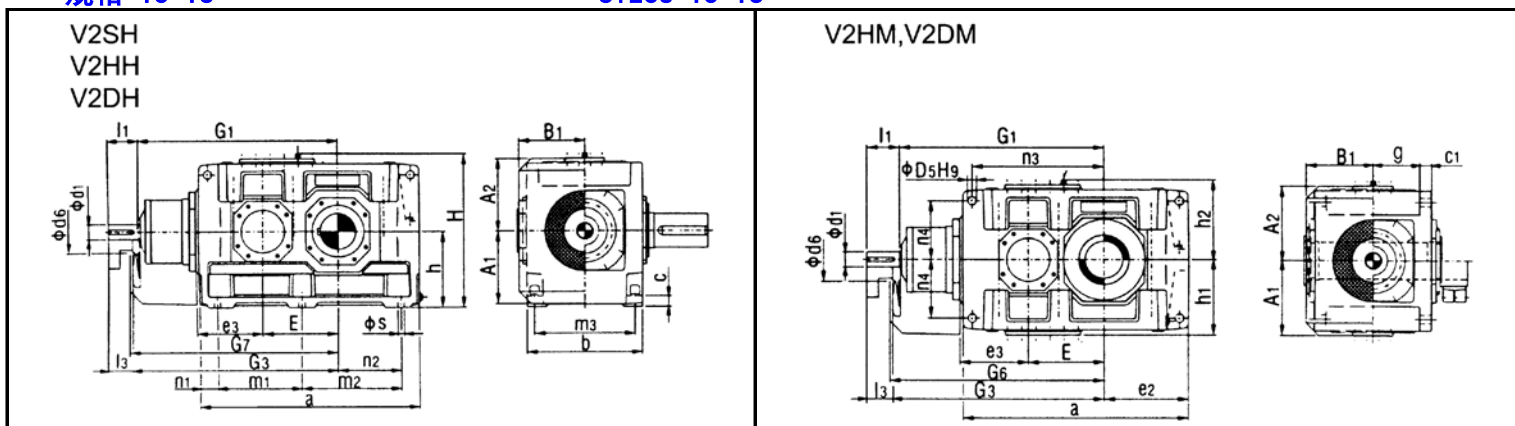

规格 Size	iN=5-11.2			iN=5.6-11.2			iN=5.6-12.5			iN=6.3-14			iN=7.1-12.5			a	A1	A2	b	B1	c	c1	d2	d6	D2	D3	D4	D5	e2	e3
	d1	l1	l3	d1	l1	l3	d1	l1	l3	d1	l1	l3	d1	l1	l3															
13	110n6	205	165												1130	430	450	655	375	60	6.1±2	200n6	245	-	-	-	48	405	380	
14									110n6	205	165				1270	430	450	655	375	60	6.1±2	210n6	245	210	215	210	48	475	380	
15	130n6	245	200												1350	490	495	765	435	70	7.2±2	230n6	280	-	-	-	55	485	450	
16							130n6	245	200						1440	490	495	765	435	70	7.2±2	240n6	280	240	245	240	55	530	450	
17				150n6	245	200									1490	540	555	885	505	80	8.1±2	250n6	380	-	-	-	65	525	510	
18													150n6	245	200	1610	540	555	885	505	80	8.1±2	270n6	380	275	285	280	65	585	510

规格 Size	E	g	G1	G2	G3	G4	G5	G7	h-1	h1	h2	H	l1	m1	m2	m3	n1	n2	n3	n4	s	润滑油Oil(1)		重量weight		
																						B2. H		B2. M		
																						(1)	(2)	B2. H	B2. M	
13	370	264	1070	390	1110	-	-	1130	440	450	460	900	350	465	465	580	100	305	675	340	35	140		120	2450	2350
14	440	264	1140	390	1180	390	535	1200	440	450	460	900	350	465	605	580	100	375	745	340	35	155		130	2825	2725
15	442	308	1277	460	1322	-	-	1340	500	490	500	1000	410	555	555	670	120	365	805	375	42	220		180	3990	3795
16	488	308	1323	460	1368	450	620	1385	500	490	500	1000	410	555	645	670	120	410	850	375	42	230		190	4345	4160
17	490	356	1435	540	1480	-	-	1500	550	555	560	1110	410	610	610	780	135	390	895	420	48	320		260	5620	5320
18	550	356	1495	540	1540	510	700	1560	550	555	560	1110	470	610	730	780	135	450	955	420	48	335		275	6150	5860

(1)* 轴封; (2)*迷宫式密封

(1)*shaft seal. (2)*Labyrinth seal.

齿轮箱
三级传动
卧式安装
类型 V3. H
规格 4-12

Gear Units
Three stage
Horizontal
Type V3. H
Sizes 4-12

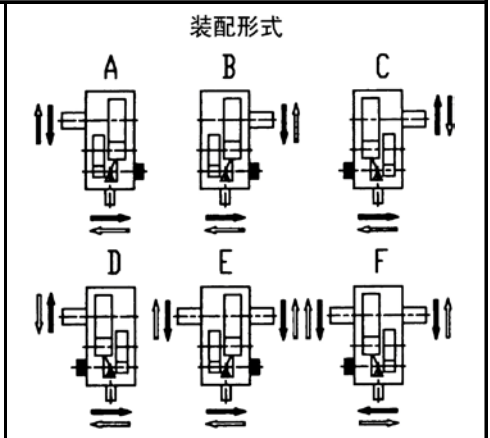
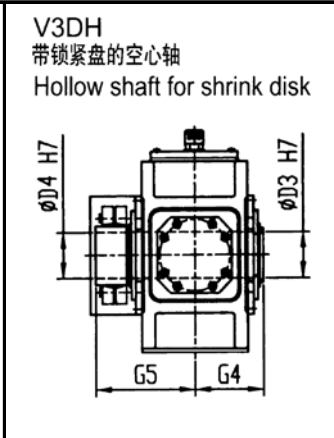
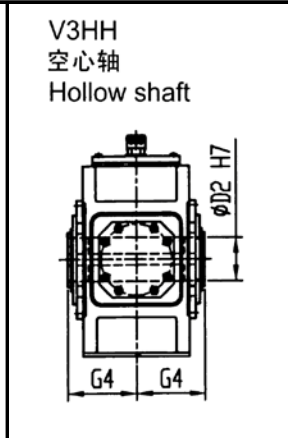
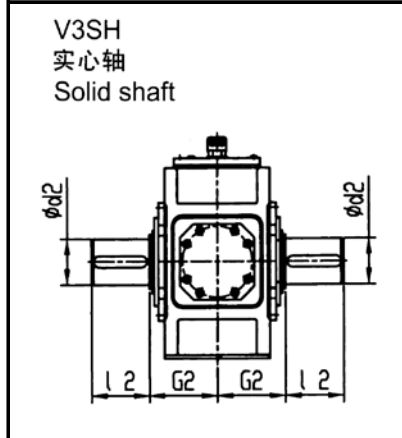
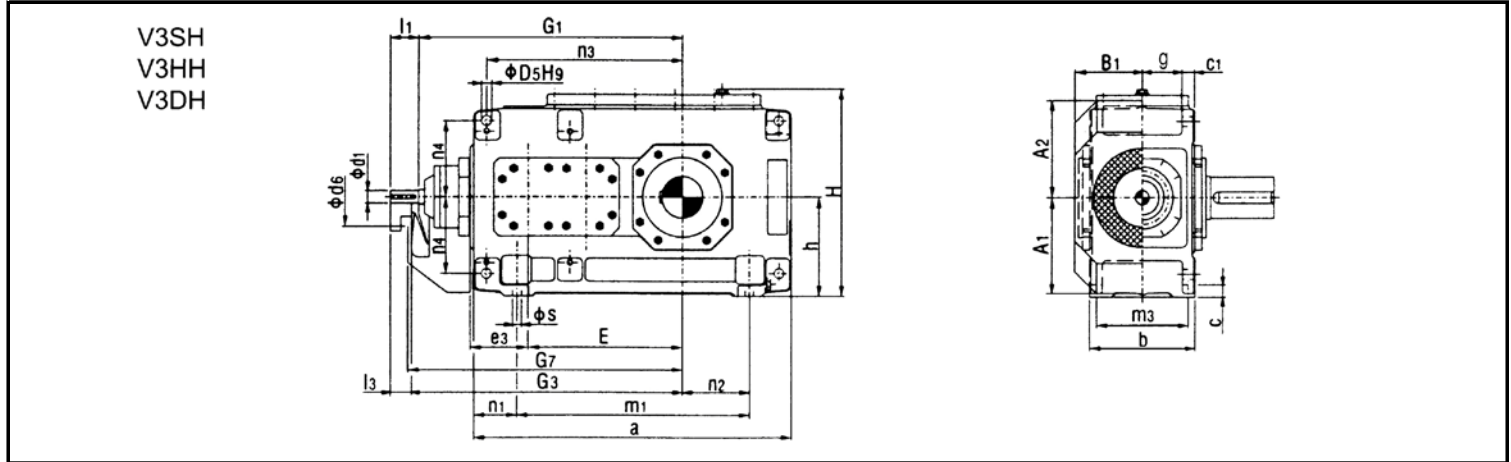

规格 Size	iN=12.5-45			iN=16-56			iN=50-71			iN=63-90			a	A1	A2	b	B1	c	c1	d2	d6	D2	D3	D4
	d1	l1	l3	d1	l1	l3	d1	l1	l3	d1	l1	l3												
4	30m6	70	50				25m6	60	40				565	195	200	215	143	28	30±1	80m6	110	80	85	85
5	35m6	80	60				28m6	60	40				640	220	235	255	168	28	30±1	100m6	130	95	100	100
6				35m6	80	60				28m6	60	40	720	220	235	255	168	28	30±1	110m6	130	105	110	110
7	45m6	100	80				35m6	80	60				785	275	275	300	193	35	36±1	120n6	165	115	120	120
8				45m6	100	80				35m6	80	60	890	275	275	300	193	35	36±1	130n6	165	125	130	130
9	55m6	110	80				40m6	100	70				925	315	325	370	231	40	45±1.5	140n6	175	135	145	140
10				55m6	110	80				40m6	100	70	1025	315	325	370	231	40	45±1.5	160n6	175	150	155	150
11	70m6	135	105				50m6	110	80				1105	370	385	430	263	50	54±1.5	170n6	190	165	170	165
12				70m6	135	105				50m6	110	80	1260	370	385	430	263	50	54±1.5	180n6	190	185	180	180

规格 Size	D5	e3	E	g	G1	G2	G3	G4	G5	G7	h-1	h5	H	l2	m1	m3	n1	n2	n3	n4	s	润滑油 Oil(1)	重量 weight (kg)
	4	24	110	270	77.5	500	140	520	140	205	530	200	100	415	170	355	180	105	85	345	150	19	9
5	24	130	315	97.5	575	165	595	165	240	605	230	130	482	210	430	220	105	100	405	180	19	15	325
6	24	130	350	97.5	610	165	630	165	240	640	230	130	482	210	510	220	105	145	440	180	19	16	380
7	28	160	385	114	690	195	710	195	280	720	170	170	572	210	545	260	120	130	500	215	24	27	550
8	28	160	430	114	735	195	755	195	285	765	160	160	582	250	650	260	120	190	545	215	24	30	635
9	36	185	450	140	800	235	830	235	330	845	175	175	662	250	635	320	145	155	585	245	28	42	890
10	36	185	500	140	850	235	880	235	350	895	175	175	662	300	735	320	145	205	635	245	28	45	1020
11	40	225	545	161	960	270	990	270	400	1010	220	220	782	300	775	370	165	180	710	300	35	71	1455
12	40	225	615	161	1030	270	1060	270	405	1080	210	210	790	300	930	370	165	265	780	300	35	76	1730

齿轮箱
三级传动
卧式安装
类型 V3. H, V3. M
规格 13-26

Gear units
Three stage
Horizontal
Type V3. H, V3. M
Sizes 13-26

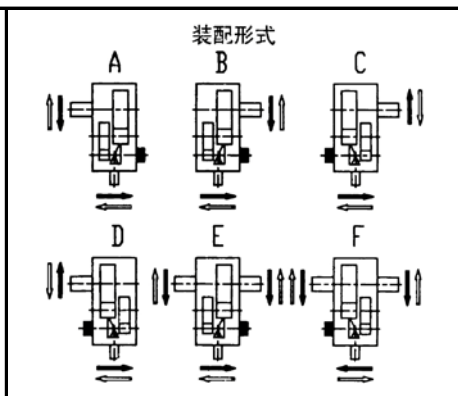
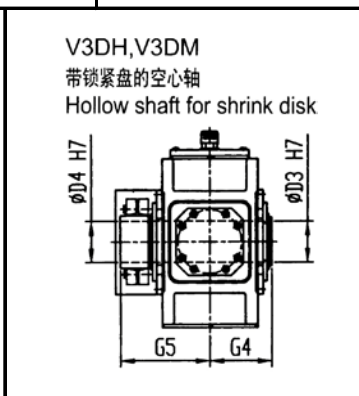
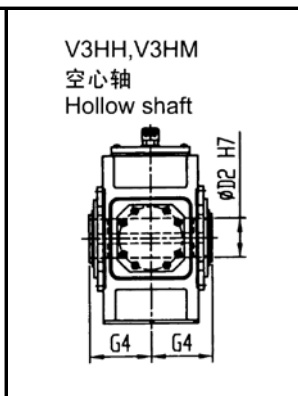
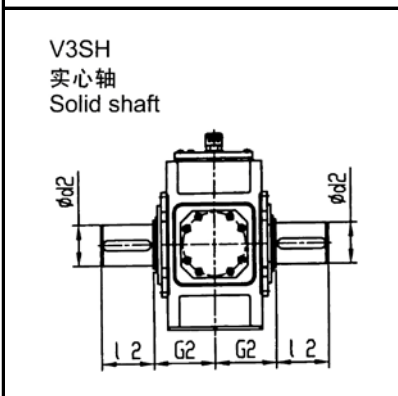
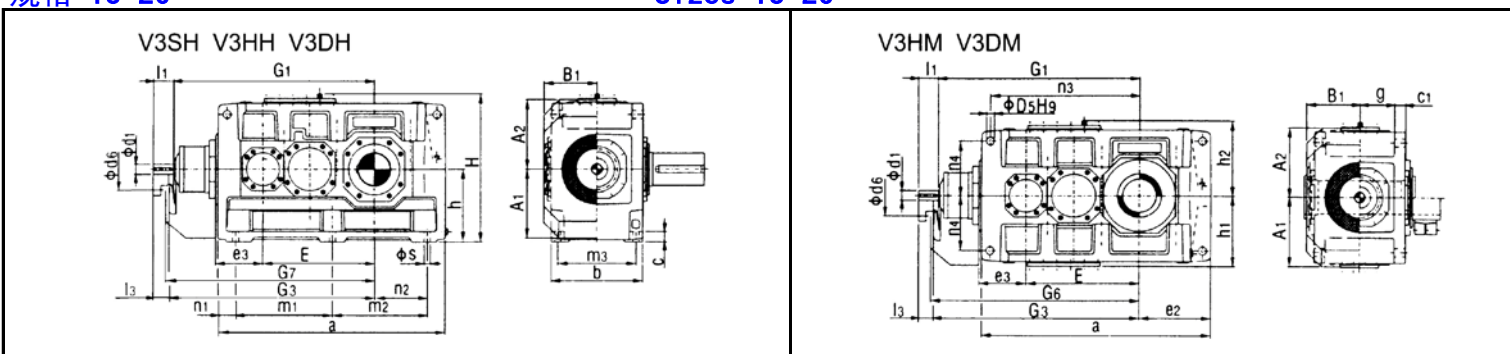

规格	IN=12.5-45			IN=14-50			IN=16-56			IN=50-71			IN=56-80			IN=63-90			a	A1	A2	b	B1	c	C1	d2	d6	D2	D3	D4			
size	d1	l1	l3	d1	l1	l3	d1	l1	l3	d1	l1	l3	d1	l1	l3	d1	l1	l3	d1	l1	l3	a	A1	A2	b	B1	c	C1	d2	d6	D2	D3	D4
13	80m6	165	130							60m6	140	105										1290	425	435	550	325	60	61±2	200n6	210	190	195	190
14							80m6	165	130													1430	425	435	550	325	60	61±2	210n6	210	210	215	210
15	90m6	165	130							70m6	140	105										1550	485	520	625	365	70	72±2	230n6	210	230	235	230
16				90m6	165	130							70m6	140	105	60m6	140	105				1640	485	520	625	365	70	72±2	240n6	210	240	245	240
17	110n6	205	165							80m6	170	130										1740	535	570	690	395	80	81±2	250n6	230	250	260	250
18				110n6	205	165				80m6	170	130										1860	535	570	690	395	80	81±2	270n6	230	275	285	280
19	130n6	245	200							100n6	210	165										2010	610	630	790	448	90	91±2	290n6	245	—	295	285
20				130n6	245	200							100n6	210	165							2130	610	630	790	448	90	91±2	300n6	245	—	315	310
21	130n6	245	200							100n6	210	165										2140	690	690	830	473	100	100±2	320n6	280	—	335	330
22				130n6	245	200							100n6	210	165							2250	690	690	830	473	100	100±2	340n6	280	—	345	340
23	150n6	245	200							110n6	210	165										2380	770	770	930	528	115	120±2	360n6	350	—	365	360
24				150n6	245	200							110n6	210	165							2510	770	770	930	528	115	120±2	380n6	350	—	385	380
25	150n6	245	200							110n6	210	165										2580	845	865	1045	585	130	120±2	400n6	380	—	405	400
26				150n6	245	200							110n6	210	165							2760	845	865	1045	585	130	120±2	420n6	380	—	435	430

规格	D5	e2	e3	E	g	G1	G2	G3	G4	G5	G7	h0-1	h1	h2	H	l2	m1	m2	m3	n1	n2	n3	n4	s	润滑油 oil(l) : weight(kg)			
																									B3.H	B3.M	B3.H	B3.M
13	48	405	265	635	211.5	1125	335	1160	335	480	1180	440	450	460	900	350	545	545	475	100	305	835	340	35	130	110	2380	2260
14	48	475	265	705	211.5	1195	335	1230	335	480	1250	440	450	460	900	350	545	685	475	100	375	905	340	35	140	115	2750	2615
15	55	485	320	762	238	1367	380	1402	380	550	1420	500	490	500	1000	410	655	655	535	120	365	1005	375	42	210	160	3730	3540
16	55	530	320	808	238	1413	380	1448	380	550	1470	500	490	500	1000	410	655	745	535	120	410	1050	375	42	22	165	3955	3765
17	55	525	370	860	259	1560	415	1600	415	600	1620	550	555	560	1110	410	735	735	600	135	390	1145	425	42	290	230	4990	4760
18	55	585	370	920	259	1620	415	1660	415	600	1680	550	555	560	1110	470	735	855	600	135	450	1205	425	42	300	235	5495	5240
19	65	590	420	997	299	1832	465	1877	465	670	1900	620	615	620	1240	470	850	850	690	155	435	1345	475	48	380	360	7000	6500
20	65	650	420	1057	299	1892	465	1937	465	670	1960	620	615	620	1240	500	850	970	690	155	495	1405	475	48	440	420	8100	7600
21	75	655	450	1067	310	1902	490	1947	490	715	1970	700	685	690	1390	500	900	900	720	170	485	1400	520	56	370	420	9200	8600
22	75	710	450	1122	310	1957	490	2002	490	725	2025	700	685	690	1390	550	900	1010	720	170	540	1455	520	56	430	490	9900	9400
23	80	730	490	1185	342	2130	540	2175	540	785	2200	780	770	790	1570	590	1010	1010	810	180	550	1560	580	56	520	560	11500	10600
24	80	795	490	1250	342	2195	540	2240	540	805	2265	780	770	790	1570	590	1010	1140	810	180	615	1625	580	56	600	650	13400	12500
25	90	790	490	1325	400	2270	605	2315	605	875	2315	860	860	860	1720	650	1090	1090	910	200	590	1685	660	66	720	790	16000	15100
26	90	880	490	1415	400	2360	605	2405	605	900	2430	860	860	860	1720	650	1090	1270	910	200	680	1775	660	66	840	920	17500	16400

齿轮箱

四级传动

卧式安装

类型 V4. H

规格 5-12

Gear units

Four stage

Horizontal

Type V4. H

Sizes 5-12

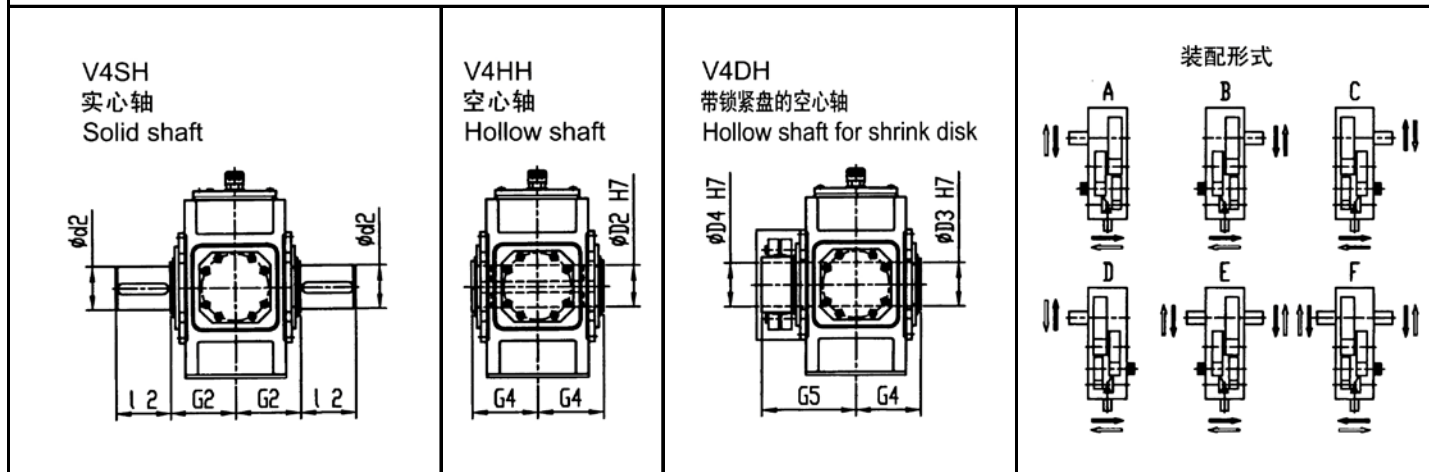
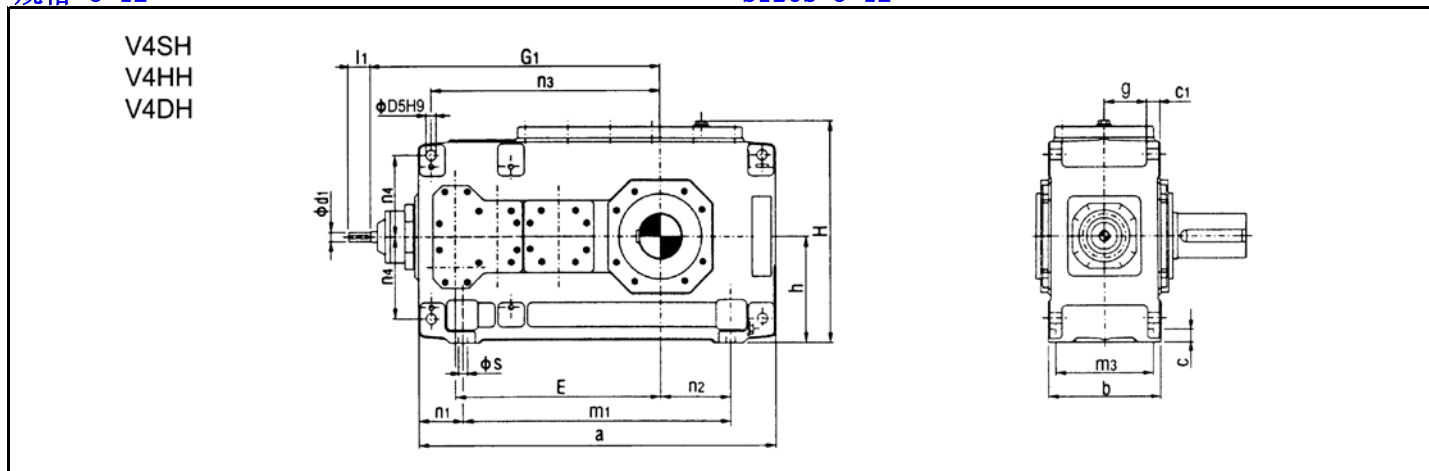

规格	IN=80-180		IN=100-224		IN=200-315		IN=250-400		a	b	c	c1	d2	D2	D3	D4	D5	E	g
size	d1	l1	d1	l1	d1	l1	d1	l1											
5	28m6	55			20k6	50			690	255	28	30±1	100m6	95	100	100	24	405	97.5
6			28m6	55			20k6	50	770	255	28	30±1	110n6	105	110	110	24	440	97.5
7	30m6	70			25m6	60			845	300	35	36±1	120n6	115	120	120	28	495	114
8			30m6	70			25m6	60	950	300	35	36±1	130n6	125	130	130	28	540	114
9	35m6	80			28m6	60			1000	370	40	45±1.5	140n6	135	145	140	36	580	140
10			35m6	80			28m6	60	1100	370	40	45±1.5	160n6	150	155	150	36	630	140
11	45m6	100			35m6	80			1200	430	50	54±1.5	170n6	165	170	165	40	705	161
12			45m6	100			35m6	80	1355	430	50	54±1.5	180n6	180	185	180	40	775	161

规格	G1	G2	G4	G5	H0-1	h5	H	l2	m1	m3	n1	n2	n3	n4	s	润滑油 oil(l)	重量 weight(kg)
size																	
5	615	165	165	240	230	100	482	210	480	220	105	100	455	180	19	16	335
6	650	165	165	240	230	100	482	210	560	220	105	145	490	180	19	18	385
7	725	195	195	280	280	140	572	210	605	260	120	130	560	215	24	30	555
8	770	195	195	285	280	130	582	250	710	260	120	190	605	215	24	33	655
9	840	235	235	330	320	135	662	250	710	320	145	155	660	245	28	48	890
10	890	235	235	350	320	135	662	300	810	320	145	205	710	245	28	50	1025
11	1010	270	270	400	380	170	782	300	870	370	165	180	805	300	35	80	1485
12	1080	270	270	405	380	160	790	300	1025	370	165	265	875	300	35	90	1750

齿轮箱

四级传动

卧式安装

类型 V4. H, V4. M

规格 13-26

Gear units

Four stage

Horizontal

Type V4. H, V4. M

Sizes 13-26

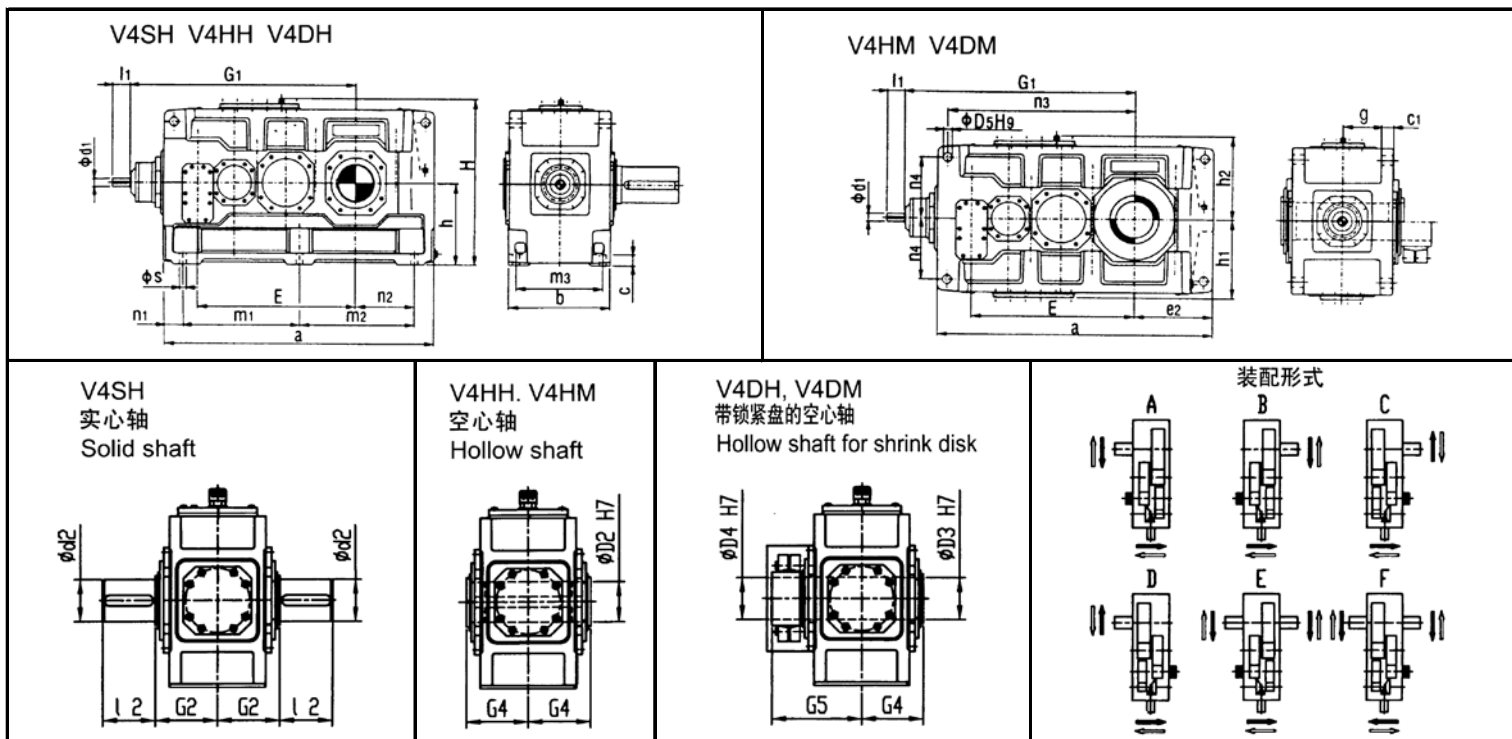

规格	IN=100-180		IN=90-200		IN=100-224		IN=200-315		IN=224-355		IN=250-400		a	b	c	c1	d2	D2	D3	D4	D5
size	d1	l1	d1	l1	d1	l1	d1	l1	d1	l1											
13	55m6	110					40m6	100			40m6	100	1395	550	60	61±2	200n6	190	195	190	48
14					55m6	110							1535	550	60	61±2	210n6	210	215	210	48
15	70m6	135					50m6	110					1680	625	70	72±2	230n6	230	235	230	55
16			70m6	135					50m6	110			1770	625	70	72±2	240n6	240	245	240	55
17	70m6	135					50m6	110					1770	690	80	81±2	250n6	250	260	250	55
18			70m6	135					50m6	110			1890	690	80	81±2	270n6	275	285	280	55
19	80m6	165					60m6	140					2030	790	90	91±2	290n6	—	295	285	65
20			80m6	165					60m6	140			2150	790	90	91±2	300n6	—	315	310	65
21	90m6	165					70m6	140					2340	830	100	100±2	320n6	—	335	330	75
22			90m6	165					70m6	140			2450	830	100	100±2	340n6	—	345	340	75
23	90m6	165					70m6	140					2530	930	115	120±2	360n6	—	365	360	80
24			90m6	165					70m6	140			2660	930	115	120±2	380n6	—	385	380	80
25	110m6	205					80m6	170					2830	1045	130	120±2	400n6	—	405	400	90
26			110m6	205					80m6	170			3010	1045	130	120±2	420n6	—	435	430	90

规格	G1	e2	E	g	G2	G4	G5	h0-1	h1	h2	H	l2	m1	m2	m3	n1	n2	n3	n4	s	润滑油 oil(l)		重量 weight(kg)	
																					B4.H	B4.M	B4.H	B4yo.M
13	1170	405	820	211.5	335	335	480	440	450	460	900	350	597.5	597.5	475	100	305	940	340	35	145	120	2395	2280
14	1240	475	890	211.5	335	335	480	440	450	460	900	350	597.5	737.5	475	100	375	1010	340	35	150	125	2735	2605
15	1402	485	987	238	380	380	550	500	490	500	1000	410	720	720	535	120	365	1135	375	42	230	170	3630	3435
16	1448	530	1033	238	380	380	550	500	490	500	1000	410	720	810	535	120	410	1180	375	42	235	175	3985	3765
17	1450	525	1035	259	415	415	600	550	555	560	1110	410	750	750	600	135	390	1175	425	42	295	230	4695	4460
18	1510	585	1095	259	415	415	600	550	555	560	1110	470	750	870	600	135	450	1235	425	42	305	235	5200	4930
19	1680	590	1190	299	465	465	670	620	615	620	1240	470	860	860	690	155	435	1365	475	48	480	440	6800	6300
20	1740	650	1250	299	465	465	670	620	615	620	1240	500	860	980	690	155	495	1425	475	48	550	510	8200	7700
21	1992	655	1387	310	490	490	715	700	685	690	1390	500	1000	1000	720	170	485	1600	520	56	540	590	9200	8600
22	2047	710	1442	310	490	490	725	700	685	690	1390	550	1000	1110	720	170	540	1655	520	56	620	680	9900	9400
23	2110	730	1505	342	540	540	785	780	770	790	1570	590	1085	1085	810	180	550	1725	580	56	710	790	11600	10700
24	2175	795	1570	342	540	540	805	780	770	790	1570	590	1085	1215	810	180	615	1790	580	56	810	910	13500	12600
25	2395	790	1675	400	605	605	875	860	860	860	1720	650	1215	1215	910	200	590	1965	660	66	1000	1110	16100	15200
26	2485	880	1785	400	605	605	900	860	860	860	1720	650	1215	1395	910	200	680	2055	660	66	1100	1200	17600	16500

齿轮箱
两级传动
立式安装
类型P2.V
规格4-12

Gear units
two stage
vertical
type P2.V
sizes 4-12

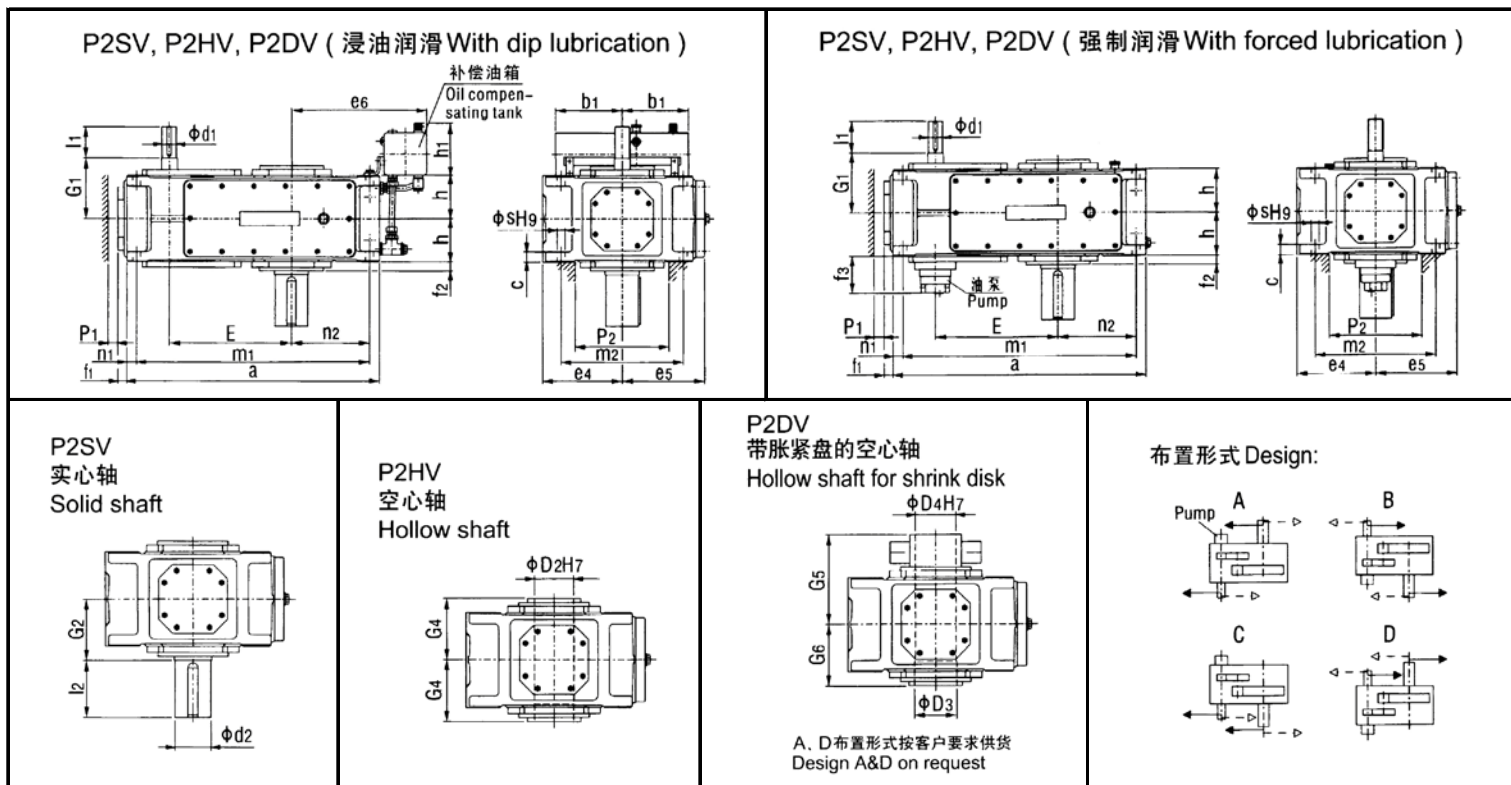

规格	IN=6.3-11.2		IN=8-14		IN=100-224		IN=12.5-22.4		a	b1	c	d2	D2	D3	D4	e4	e5	e6	E
size	d1	l1	d1	l1	d1	l1	d1	l1											
4	45m6	100			32m6	80			565	150	30±1	80m6	80	85	85	200	215	320	270
5	50m6	100			38m6	80			640	240	30±1	100m6	95	100	100	230	252	385	315
6			50m6	100			38m6	80	720	240	30±1	110m6	105	110	110	230	252	425	350
7	60m6	135			50m6	110			785	240	36±1	120m6	115	120	120	280	292	425	385
8			60m6	135			50m6	110	890	240	36±1	130m6	125	130	130	280	302	485	430
9	75m6	140			60m6	140			925	330	45±1.5	140m6	135	145	140	320	342	560	450
10			75m6	140			60m6	140	1025	330	45±1.5	160m6	150	155	150	320	342	610	500
11	90m6	165			70m6	140			1105	330	54±1.5	170m6	165	170	165	380	402	595	545
12			90m6	165			70m6	140	1260	330	54±1.5	180m6	180	185	180	380	410	680	615

规格	size	f1	f2	f3	G1	G2	G4	G5	G6	h	h1	l2	m1	m2	n1	n2	p1	p2	s	润滑油 oil(l)		重量 weight
																				(1)**	(2)**	KG
4	28	22	-	170	140	140	205	140	107.5	165	170	505	300	30	160	35	220	24	23	-	190	
5	38	28	150	195	165	165	240	165	127.5	205	210	580	360	30	175	35	270	24	35	17.5	300	
6	38	28	150	195	165	165	240	165	127.5	205	210	660	360	30	220	35	270	24	37	18.5	355	
7	42	30	145	210	195	195	280	195	150	205	210	715	430	35	215	35	330	28	62	31	505	
8	42	32	145	210	195	195	285	195	150	205	250	820	430	35	275	35	330	28	69	35	590	
9	42	32	135	240	235	235	330	235	185	275	250	845	490	40	260	40	370	36	98	49	830	
10	42	32	135	240	235	235	350	235	185	275	300	945	490	40	310	40	370	36	110	55	960	
11	48	35	145	275	270	270	400	270	215	275	300	1005	600	50	295	50	440	40	160	80	1335	
12	48	35	145	275	270	270	405	270	215	275	300	1160	600	50	380	50	440	40	180	90	1615	

齿轮箱

两级传动
立式安装
类型 P2.V
规格 13-22

Gear Units

Two stage
Vertical
Type P2.V
Sizes 13-12

P2SV, P2HV, P2DV (强制润滑 With Forced lubrication)

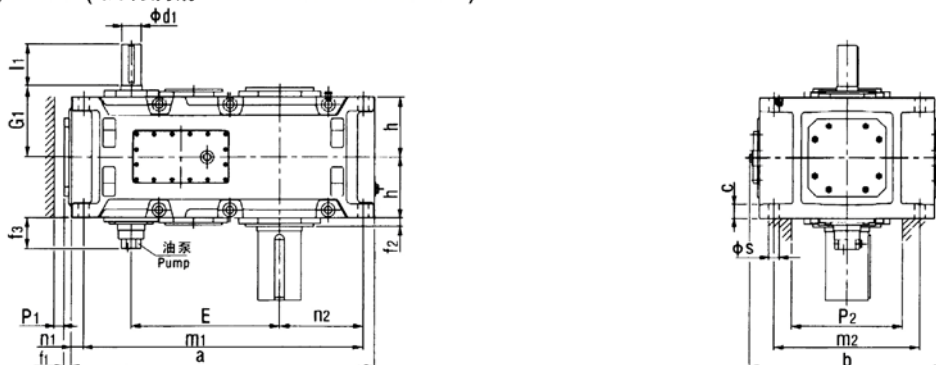

P2SV
实心轴
Solid shaft

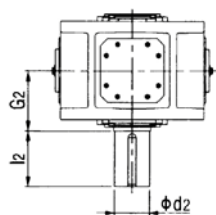

P2HV
空心轴
Hollow shaft

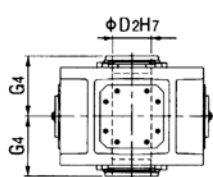

P2DV
带胀紧盘的空心轴
Hollow shaft for shrink disk

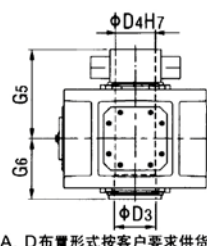

A、D布置形式按客户要求供货
Design A&D on request

布置形式 Design:

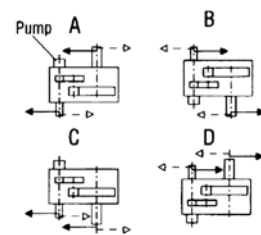

规格 Size	$i_N=6.3-11.2$		$i_N=7.1-12.5$		$i_N=8-14$		$i_N=12.5-20$		$i_N=14-22.4$		$i_N=16-25$		a	b	c	d2	D2	D3	D4	E
	d_1	l_1	d_1	l_1	d_1	l_1	d_1	l_1	d_1	l_1	d_1	l_1								
13	100m6	205					85m6	170					1290	900	61 ± 2	200n6	190	195	190	635
14					100m6	205					85m6	170	1430	900	61 ± 2	210n6	210	215	210	705
15	120m6	210					100m6	210					1550	980	72 ± 2	230n6	230	235	230	762
16			120n6	210					100m6	210			1640	980	72 ± 2	240n6	240	245	240	808
17	125m6	245					110m6	210					1740	1110	81 ± 2	250n6	250	260	250	860
18			125n6	245					110m6	210			1860	1110	81 ± 2	270n6	275	285	280	920
19	按客户要求供货 On request																			
20																				
21																				
22																				

规格 Size	f1	f2	f3	G1	G2	G4	G5	G6	h	l2	m1	m2	n1	n2	P1	P2	S	润滑油 (1) **	重量 weight (kg)	
	13	53	35	130	330	335	335	480	335	272.5	350	1195	680	50	360	50	500	48	80	1880
14	53	35	130	330	335	335	480	335	272.5	350	1335	680	50	430	50	500	48	90	2430	
15	63	42	130	365	380	380	550	380	310	410	1435	750	60	430	50	570	55	140	3240	
16	63	42	130	365	380	380	550	380	310	410	1525	750	60	475	50	570	55	150	3465	
17	60	42	170	420	415	415	600	415	340	410	1610	850	70	465	70	630	55	175	4420	
18	60	42	170	420	415	415	600	415	340	470	1730	850	70	525	70	630	55	185	4870	
19	按客户要求供货 On request																			
20																				
21																				
22																				

齿轮箱

三级传动
立式安装
类型 P3.V
规格 5-12

Gear Units

Three stage
Vertical
Type P3.V
Sizes 5-12

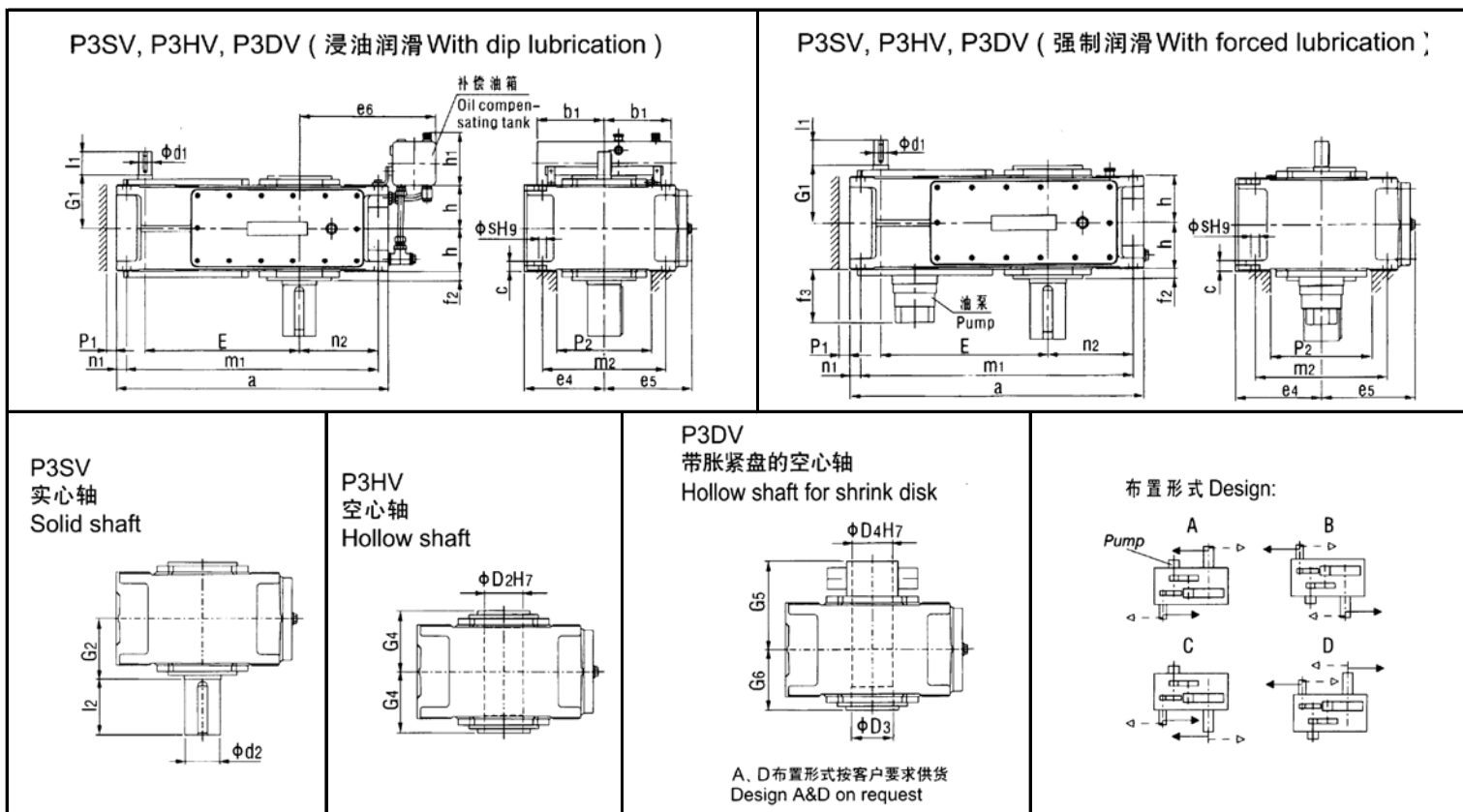

规格 Size	$i_N=25-45$		$i_N=31.5-56$		$i_N=50-63$		$i_N=63-80$		$i_N=71-90$		$i_N=90-112$		a	b1	c	d2	D2	D3	D4	e4	e5
	d_1	l_1	d_1	l_1	d_1	l_1	d_1	l_1	d_1	l_1	d_1	l_1									
5	40m6	70			30m6	50			24K6	40			690	240	30 ± 1	100m6	95	100	100	230	252
6			40m6	70			30m6	50			24K6	40	770	240	30 ± 1	110m6	105	110	110	230	252
7	45m6	80			35m6	60			28m6	50			845	240	36 ± 1	120m6	115	120	120	280	292
8			45m6	80			35m6	60			28m6	50	950	240	36 ± 1	130m6	125	130	130	280	302
9	60m6	125			45m6	100			32m6	80			1000	330	45 ± 1.5	140m6	135	145	140	320	342
10			60m6	125			45m6	100			32m6	80	1100	330	45 ± 1.5	160m6	150	155	150	320	342
11	70m6	120			50m6	80			42m6	70			1200	330	54 ± 1.5	170m6	165	170	165	380	402
12			70m6	120			50m6	80			42m6	70	1355	330	54 ± 1.5	180m6	180	185	180	380	410

规格 Size	e6	E	f2	f3	G1	G2	G4	G5	G6	h	h1	12	m1	m2	n1	n2	P1	P2	s	润滑油		重量 weight (kg)
																				(1) **	(2) **	
5	385	405	28	190	160	165	165	240	165	127.5	205	210	630	360	30	175	35	270	24	36	14	320
6	425	440	28	190	160	165	165	240	165	127.5	205	210	710	360	30	220	35	270	24	40	17	365
7	425	495	30	185	185	195	195	280	195	150	205	210	775	430	35	215	35	330	28	64	35	540
8	485	540	32	185	185	195	195	285	195	150	205	250	880	430	35	275	35	330	28	75	47	625
9	560	580	32	170	230	235	235	330	235	185	275	250	920	490	40	260	40	370	36	110	55	875
10	610	630	32	170	230	235	235	350	235	185	275	300	1020	490	40	310	40	370	36	120	60	1020
11	595	705	35	170	255	270	270	400	270	215	275	300	1100	600	50	295	50	440	40	190	70	1400
12	680	775	35	170	255	270	270	405	270	215	275	300	1255	600	50	380	50	440	40	205	80	1675

齿轮箱
三级传动
立式安装
类型P3.V
规格13-22

Gear Units
Three stage
Vertical
Type P3.V
Sizes 13-22

P3SV, P3HV, P3DV (强制润滑 With forced lubrication)

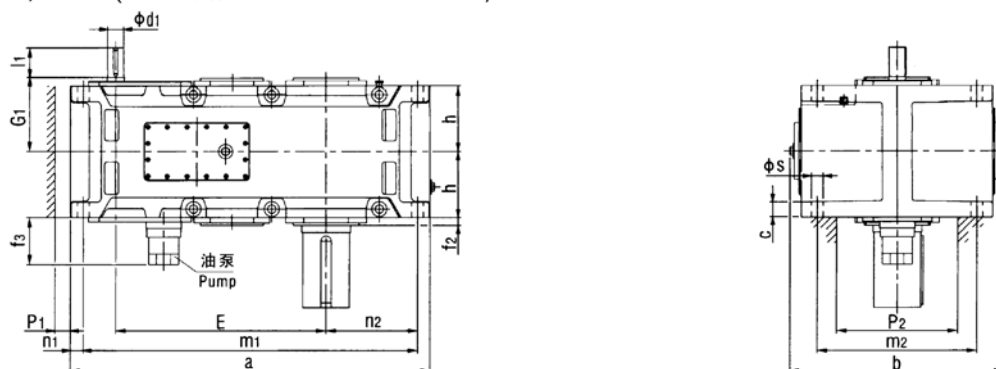

P3SV
 实心轴
 Solid shaft

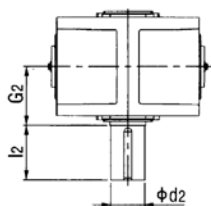

P3HV
 空心轴
 Hollow shaft

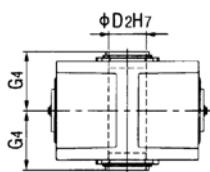

P3DV
 带胀紧盘的空心轴
 Hollow shaft for shrink disk

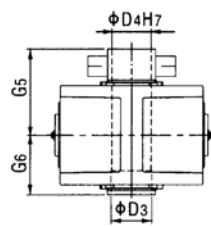

A、D布置形式按客户要求供货
 Design A&D on request

布置形式 Design:

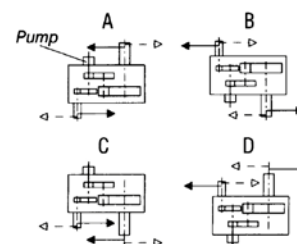

规格 Size	$i_N=22.4-45$		$i_N=25-50$		$i_N=28-56$		$i_N=50-63$		$i_N=56-71$		$i_N=63-80$		$i_N=71-90$		$i_N=80-100$		$i_N=90-112$		a	b	c	d_2	D_2
	d_1	l_1	d_1	l_1	d_1	l_1	d_1	l_1	d_1	l_1	d_1	l_1	d_1	l_1	d_1	l_1	d_1	l_1					
13	85m6	160					60m6	135					50m6	110					1395	900	61±2	200n6	190
14					85m6	160						60m6	135				50m6	110	1535	900	61±2	210n6	210
15	100m6	200					75m6	140					60m6	140					1680	980	72±2	230n6	230
16			100m6	200				75m6	140					60m6	140				1770	980	72±2	240n6	240
17	100m6	200					75m6	140					60m6	140					1770	1110	81±2	250n6	250
18			100m6	200				75m6	140					60m6	140				1890	1110	81±2	270n6	275
19	按客户要求供货 On request																						
20																							
21																							
22																							

规格 Size	D3	D4	E	f2	f3	G1	G2	G4	G5	G6	h	l2	m1	m2	n1	n2	P1	P2	s	润滑油Oil (l)	重量weight (kg)
13	190	190	820	35	170	310	335	335	480	335	272.5	350	1300	680	50	360	50	500	48	120	2155
14	215	210	890	35	170	310	335	335	480	335	272.5	350	1440	680	50	430	50	500	48	140	2490
15	235	230	987	42	170	350	380	380	550	380	310	410	1565	750	60	430	50	570	55	200	3260
16	245	240	1033	42	170	350	380	380	550	380	310	410	1655	750	60	475	50	570	55	220	3625
17	260	250	1035	42	210	380	415	415	600	415	340	410	1640	850	70	465	70	630	55	240	4250
18	285	280	1095	42	210	380	415	415	600	415	340	470	1760	850	70	525	70	630	55	250	4740
19	按客户要求供货 On request																				
20																					
21																					
22																					

齿轮箱
四级传动
立式安装
类型P4.V
规格7-12

Gear Units
Four stage
Vertical
Type P4.V
Sizes 7-12

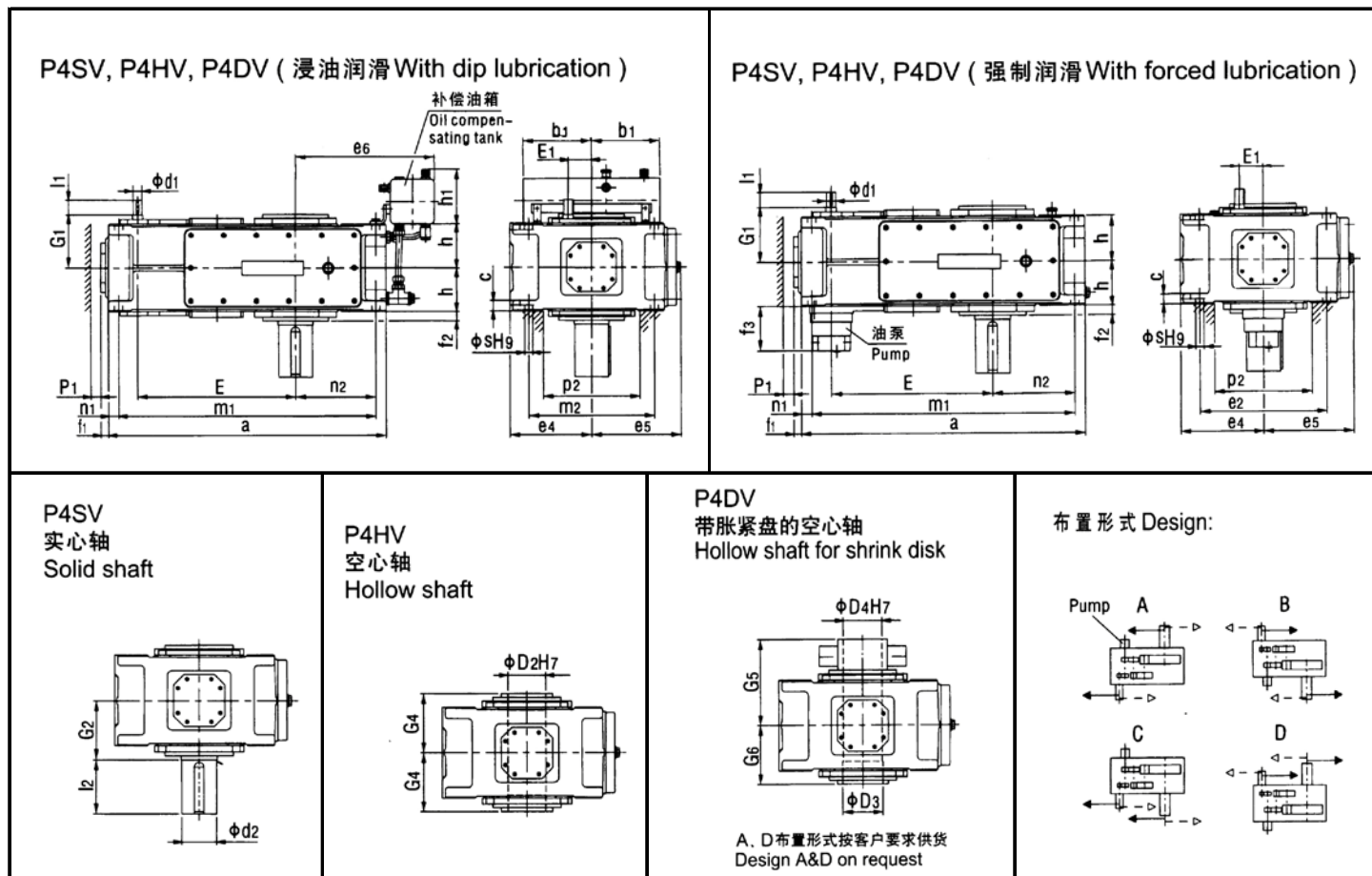

规格 Size	$i_N=100-180$		$i_N=125-224$		$i_N=200-355$		$i_N=250-450$		a	b_1	c	d_2	D_2	D_3	D_4	e_4	e_5	e_6	E
	d_1	l_1	d_1	l_1	d_1	l_1	d_1	l_1											
7	30m6	50			25m6	60			845	240	36 ± 1	120n6	115	120	120	280	292	425	495
8			30m6	50			24k6	40	950	240	36 ± 1	130n6	125	130	130	280	302	485	540
9	35m6	60			28m6	60			1000	330	45 ± 1.5	140n6	135	145	140	320	342	560	580
10			35m6	60			28m6	50	1100	330	45 ± 1.5	160n6	150	155	150	320	342	610	630
11	45m6	100			35m6	80			1200	330	54 ± 1.5	170n6	165	170	165	380	402	595	705
12			45m6	100			32m6	80	1353	330	54 ± 1.5	180n6	180	185	180	380	410	680	775

规格 Size	E_1	f_1	f_2	f_3	G_1	G_2	G_4	G_5	G_6	h	h_1	l_2	m_1	m_2	n_1	n_2	P_2	s	润滑油oil (l)		重量 weight (kg)
																			(1)**	(2)**	
7	80	37	30	160	180	195	195	280	195	150	205	210	775	430	35	215	330	28	60	30	550
8	80	37	32	160	180	195	195	285	195	150	205	250	880	430	35	275	330	28	65	35	645
9	90	43	32	170	215	235	235	330	235	185	275	250	920	490	40	260	370	36	105	45	875
10	90	43	32	170	215	235	235	350	235	185	275	300	1020	490	40	310	370	36	120	60	1010
11	110	47	35	170	250	270	270	400	270	215	275	300	1100	600	50	295	440	40	175	80	1460
12	110	47	35	170	250	270	270	405	270	215	275	300	1255	600	50	380	440	40	200	95	1725

(1)** 浸油润滑; (2)** 强制润滑

(1)** Dip lubrication, (2)** Forced lubrication

齿轮箱
 四级传动
 立式安装
 类型 P4V
 规格 13-22

Gear Units
 Four stage
 Vertical
 Type P4V
 Sizes 13-22

P4SV, P4HV, P4DV (强制润滑 With forced lubrication)

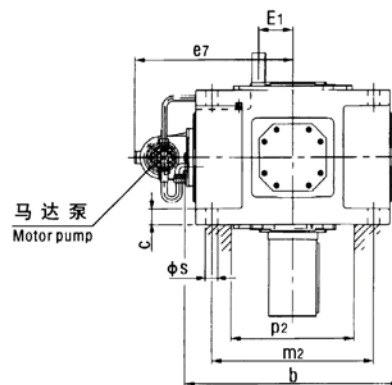
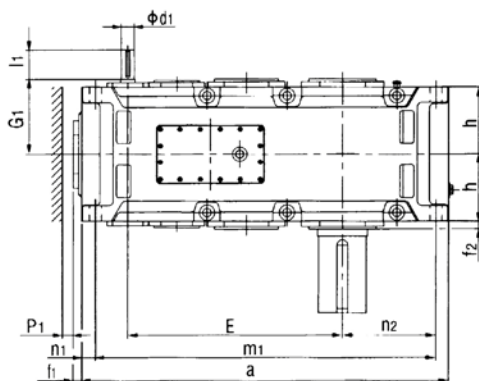

P4SV
实心轴
Solid shaft

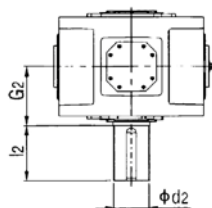

P4HV
空心轴
Hollow shaft

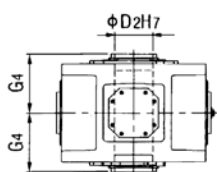

P4DV
带胀紧盘的空心轴
Hollow shaft for shrink disk

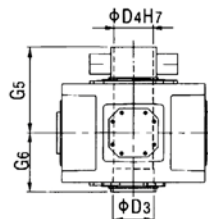

A, D布置形式按客户要求供货
Design A&D on request

布置形式 Design:

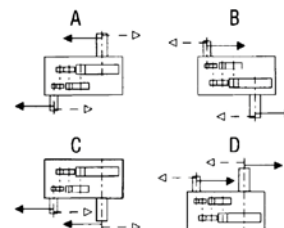

规格 Size	i _N =100-180		i _N =112-200		i _N =125-224		i _N =200-355		i _N =224-400		i _N =250-450		a	b	c	d ₂	D ₂	D ₃	D ₄	e7
	d ₁	l ₁	d ₁	l ₁	d ₁	l ₁	d ₁	l ₁	d ₁	l ₁	d ₁	l ₁								
13	50m6	100					38m6	80					1395	900	61±2	200n6	190	195	190	690
14					50m6	100					38m6	80	1535	900	61±2	210n6	210	215	210	690
15	60m6	135					50m6	110					1680	980	72±2	230n6	230	235	230	730
16			60m6	135					50m6	110			1770	980	72±2	240n6	240	245	240	730
17	60m6	105					50m6	80					1770	1110	81±2	250n6	250	260	250	790
18			60m6	105					50m6	80			1890	1110	81±2	270n6	275	285	280	790
19	按客户要求供货 On request																			
20																				
21																				
22																				

规格 Size	E	E1	f1	f2	G1	G2	G4	G5	G6	h	l2	m1	m2	n1	n2	P1	P2	s	润滑油 oil (l)	重量 weight (kg)
13	820	130	47	35	305	335	480	335	335	272.5	350	1300	680	50	360	50	500	48	110	2270
14	890	130	47	35	305	335	480	335	335	272.5	350	1440	680	50	430	50	500	48	120	2600
15	987	160	56	42	345	380	550	380	380	310	410	1565	750	60	430	60	570	55	170	3440
16	1033	160	56	42	345	380	550	380	380	310	410	1655	750	60	475	60	570	55	180	3740
17	1035	160	53	42	380	415	600	415	415	340	410	1640	850	70	465	70	630	55	220	4445
18	1095	160	53	42	380	415	600	415	415	340	470	1760	850	70	525	70	630	55	230	4915
19	按客户要求供货 On request																			
20																				
21																				
22																				

齿轮箱
两级传动
立式安装
类型 V2V
规格 4-12

Gear Units
Two stage
Vertical
Type V2V
Sizes 4-12

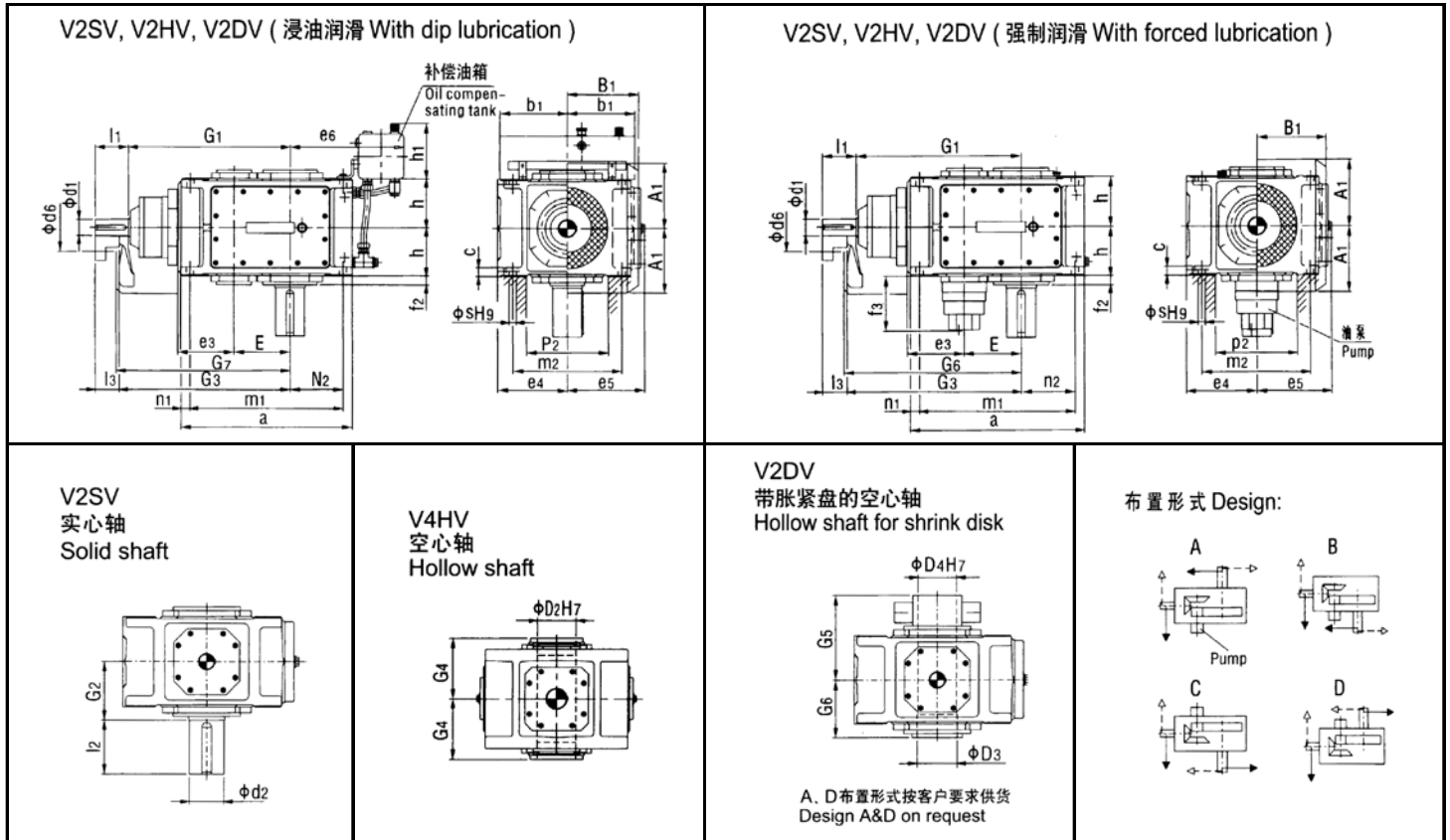

规格 Size	$i_N=5-11.2$			$i_N=6.3-14$			a	A_1	b_1	B_1	c	d_2	d_6	D_2	D_3	D_4	e_3	e_4	e_5
	d_1	l_1	l_3	d_1	l_1	l_3													
4	45m6	100	80				505	188	150	200	30±1	80m6	150	80	85	85	100	200	215
5	55m6	110	80				565	215	240	235	30±1	100m6	160	95	100	100	185	230	252
6				55m	110	80	645	215	240	235	30±1	110n6	160	105	110	110	185	230	252
7	70m6	135	105				690	250	240	285	36±1	1200n6	210	115	120	120	225	280	302
8				70m	135	105	795	250	240	285	36±1	130n6	210	125	130	130	225	280	302
9	80m6	165	130				820	270	330	325	45±1	140n6	195	135	145	140	265	320	342
10				80m6	165	130	920	270	330	325	45±1	160n6	195	150	155	150	265	320	342
11	90m6	165	130				975	328	330	385	54±1	170n6	210	165	170	165	320	380	410
12				90m6	165	130	1130	328	330	385	54±1	180n6	210	180	185	180	320	380	410

规格 Size	e_6	E	f_2	f_3	G_1	G_2	G_3	G_4	G_5	G_6	G_7	h	h_1	l_2	m_1	m_2	n_1	n_2	P_2	s	润滑油 oil (l)		重量 weight t (kg)
																					(1)**	(2)**	
4	320	160	26	-	465	170	485	170	235	170	495	135	165	170	445	300	30	160	220	24	30	-	235
5	385	185	30	190	535	200	565	200	275	200	575	160	205	210	505	360	30	175	270	24	45	25	360
6	425	220	30	190	570	200	600	200	275	200	610	160	205	210	585	360	30	220	270	24	55	28	410
7	425	225	32	200	640	235	670	235	320	235	685	190	205	210	620	430	35	215	330	28	80	40	615
8	485	270	32	200	685	235	715	235	325	235	730	190	205	250	725	430	35	275	330	28	100	45	700
9	560	265	45	200	755	270	790	270	365	270	805	220	275	250	740	490	40	260	370	36	125	60	1000
10	610	315	45	200	805	270	840	270	385	270	855	220	275	300	840	490	40	310	370	36	150	70	1155
11	595	320	47	200	925	320	960	320	450	320	980	265	275	300	875	600	50	295	440	40	220	100	1640
12	680	390	47	200	995	320	1030	320	455	320	1050	265	275	300	1030	600	50	380	440	40	240	110	1910

(1)** 浸油润滑; (2)** 强制润

(1)** Dip lubrication, (2)** Forced lubrication.

齿轮箱
 两级传动
 立式安装
 类型 V2V
 规格 13-18

Gear Units
 Two stage
 Vertical
 Type V2V
 Sizes 13-18

V2SV, V2HV, V2DV (强制润滑 With forced lubrication)

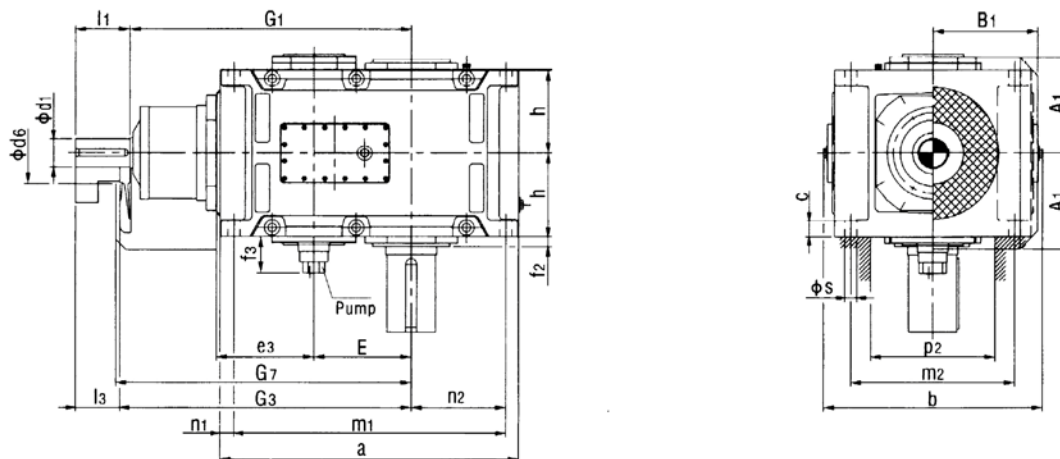

V2SV
 实心轴
 Solid shaft

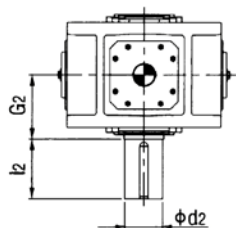

V2HV
 空心轴
 Hollow shaft

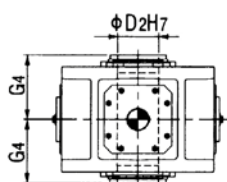

V2DV
 带胀紧盘的空心轴
 Hollow shaft for shrink disk

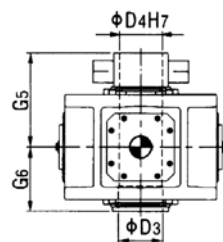

布置形式 Design:

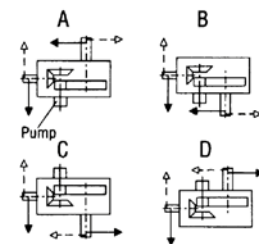

A, D 布置形式按客户要求供货
 Design A&D on request

规格 Size	$i_N=5-11.2$			$i_N=5.6-11.2$			$i_N=5.6-12.5$			$i_N=6.3-14$			$i_N=7.1-12.5$			a	A_1	b	B_1	c	d_2	d_6	D_2	D_3
	d_1	l_1	l_3	d_1	l_1	l_3	d_1	l_1	l_3	d_1	l_1	l_3	d_1	l_1	l_3									
13	110n6	205	165												1130	375	900	450	61±2	200n6	245	190	195	
14										110n6	205	165			1270	375	900	450	61±2	210n6	245	210	215	
15	130n6	245	200												1350	435	980	495	72±2	230n6	280	230	235	
16							130n6	245	200						1440	435	980	495	72±2	240n6	280	240	245	
17				150n6	245	200									1490	505	1110	555	81±2	250n6	380	250	260	
18													150n6	245	200	1610	505	1110	555	81±2	270n6	380	275	285

规格 Size	D_4	e_3	E	f_2	f_3	G_1	G_2	G_3	G_4	G_5	G_6	G_7	h	l_2	m_1	m_2	n_1	n_2	P_2	s	润滑油 oil (l)	重量 weight (kg)
13	190	380	370	38	200	1070	335	1110	335	480	335	1130	325	350	1035	680	50	360	500	48	125	2350
14	210	380	440	45	200	1140	335	1180	335	480	335	1200	325	350	1175	680	50	430	500	48	140	2725
15	230	450	442	75	200	1277	380	1322	380	550	380	1340	380	410	1235	750	60	430	570	55	190	3795
16	240	450	488	75	200	1323	380	1368	380	550	380	1385	380	410	1325	750	60	475	570	55	200	4160
17	250	510	490	98	200	1435	415	1480	415	600	415	1500	437.5	410	1360	840	70	465	630	65	270	5320
18	280	510	550	98	200	1495	415	1540	415	600	415	1560	437.5	470	1480	840	70	525	630	65	295	5860

齿轮箱
两级传动
立式安装
类型 V3V
规格 4-12

Gear Units
Two stage
Vertical
Type V3V
Sizes 4-12

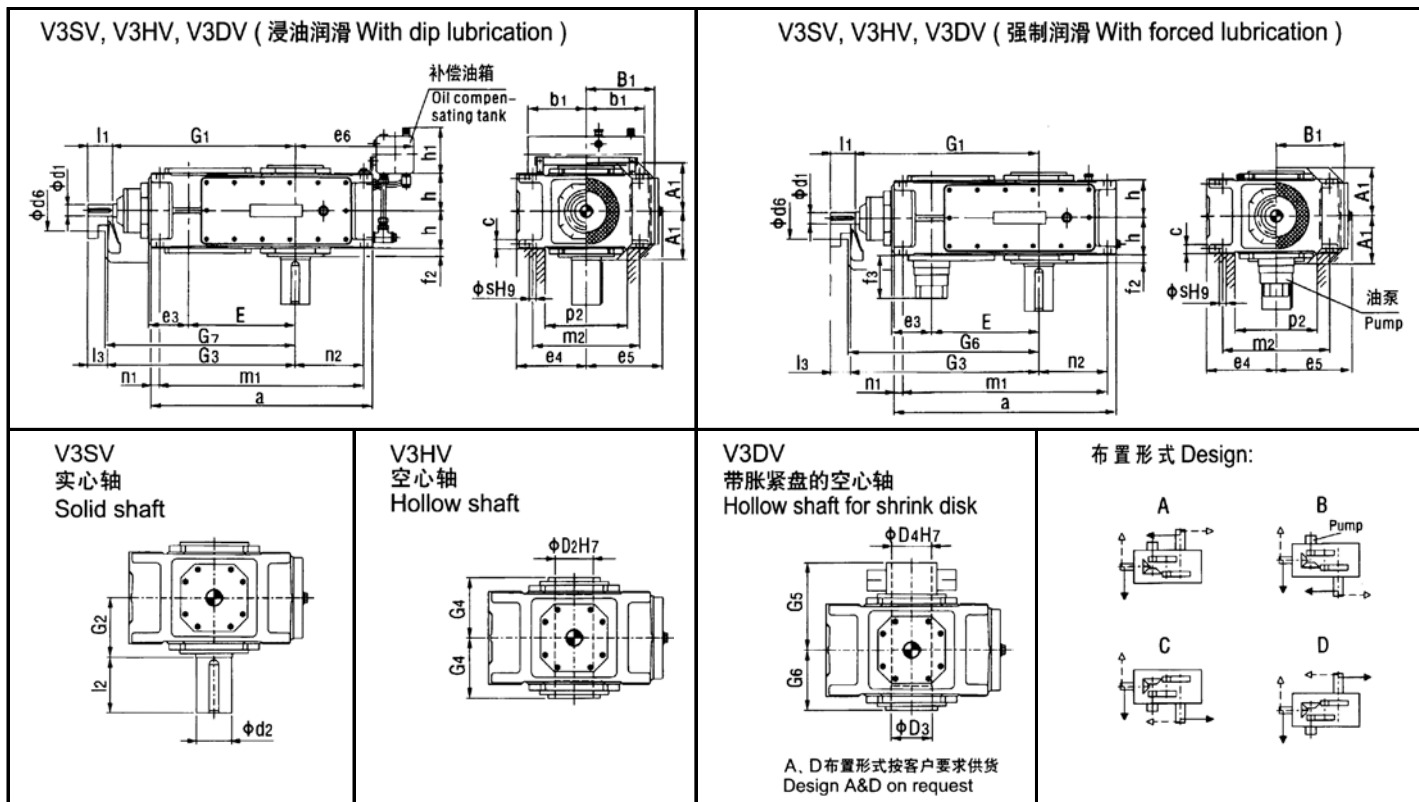

规格 Size	$i_N=12.5-45$			$i_N=16-56$			$i_N=50-71$			$i_N=63-90$			a	A_1	b_1	B_1	c	d_2	d_6	D_2	D_3	D_4	e_3
	d_1	l_1	l_3	d_1	l_1	l_3	d_1	l_1	l_3	d_1	l_1	l_3											
4	30m6	70	50				25m6	60	40				565	143	150	200	30±1	80m6	110	80	85	85	110
5	35m6	80	60				28m6	60	40				640	168	240	235	30±1	100m6	130	95	100	100	130
6				35m6	80	60							720	168	240	235	30±1	110n6	130	105	110	110	130
7	45m6	100	80				35m6	80	60				785	193	240	275	36±1	120n6	165	115	120	120	160
8				45m6	100	80							890	193	240	275	36±1	130n6	165	125	130	130	160
9	55m6	110	80				40m6	100	70				925	231	330	325	45±1.5	140n6	175	135	145	140	185
10				55m6	110	80							1025	231	330	325	45±1.5	160n6	175	150	155	150	185
11	70m6	135	105				50m6	110	80				1105	263	330	385	54±1.5	170n6	190	165	170	165	225
12				70m6	135	105							1260	263	330	385	54±1.5	180n6	190	180	185	180	225

规格 Size	e_5	e_6	E	f_2	f_3	G_1	G_2	G_3	G_4	G_5	G_6	G_7	h	h_1	l_2	m_1	m_2	n_1	n_2	P_2	s	润滑油 oil (l)		重量 weig ht (kg)
																						(1)**	(2)**	
4	215	320	270	22	-	500	140	520	140	205	140	530	108	165	170	505	300	30	160	220	24	28	-	210
5	252	385	315	28	190	575	165	595	165	240	165	605	128	205	210	580	360	30	175	270	24	34	17	325
6	252	425	350	28	190	610	165	630	165	240	165	640	128	205	210	660	360	30	220	270	24	36	18	380
7	292	425	385	30	190	690	195	710	195	280	195	720	150	205	210	715	430	35	215	330	28	60	25	550
8	302	485	430	32	190	735	195	755	195	285	195	765	150	205	250	820	430	35	275	330	28	68	30	635
9	342	560	450	32	180	800	235	830	235	330	235	845	185	275	250	845	490	40	260	370	36	120	55	890
10	342	610	500	32	180	850	235	880	235	350	235	895	185	275	300	945	490	40	310	370	36	130	60	1020
11	402	595	545	35	180	960	270	990	270	400	270	1010	215	275	300	1005	600	50	295	440	40	200	90	1455
12	410	680	615	35	180	1030	270	1060	270	405	270	1080	215	275	300	1160	600	50	380	440	40	220	100	1730

(1)** 浸油润滑; (2)** 强制润;

(1)** Dip lubrication, (2)** Forced lubrication.

齿轮箱
 三级传动
 立式安装
 类型V3.V
 规格13-22

Gear Units
 Three stage
 Vertical
 Type V3.V
 Sizes 13-22

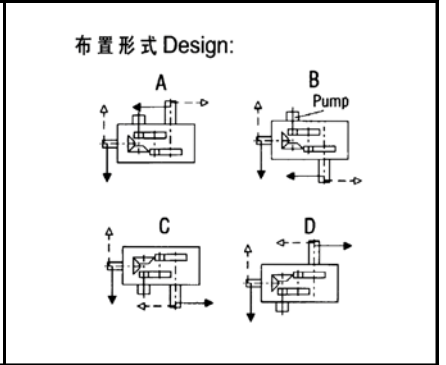
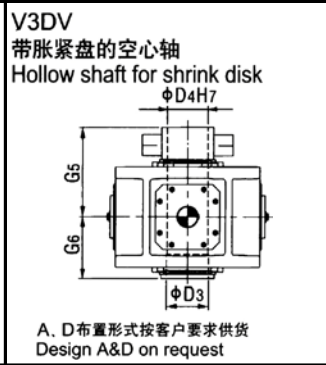
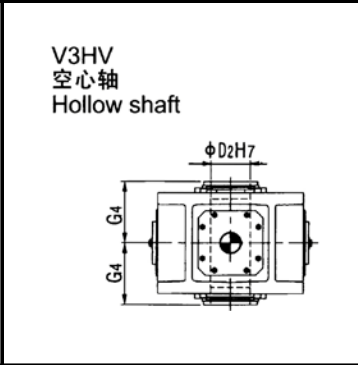
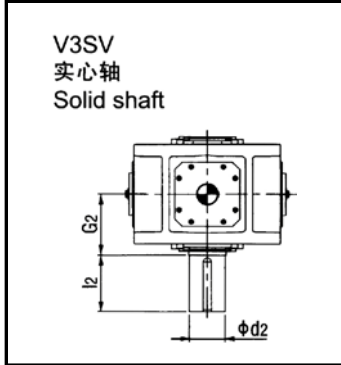
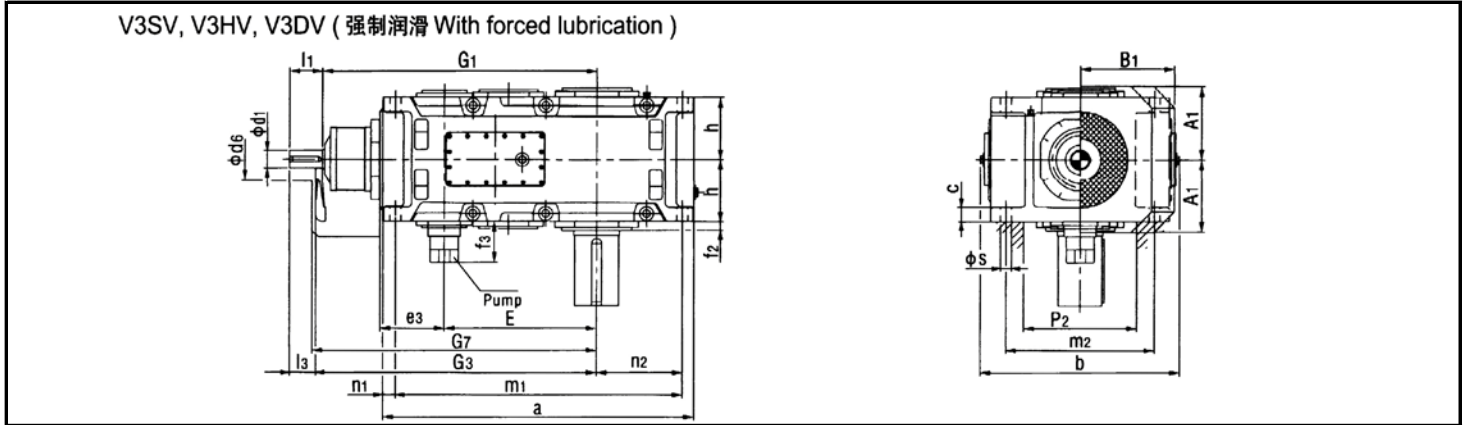

规格 Size	$i_N=12.5-45$			$i_N=14-50$			$i_N=16-56$			$i_N=50-71$			$i_N=56-80$			$i_N=63-90$			a	A ₁	b	B ₁	c	d ₂	d ₆	D ₂	
	d ₁	l ₁	l ₃	d ₁	l ₁	l ₃	d ₁	l ₁	l ₃	d ₁	l ₁	l ₃	d ₁	l ₁	l ₃	d ₁	l ₁	l ₃									
13	80m6	165	130							60m6	140	105								1290	325	900	475	61±2	200n6	210	190
14							80m6	165	130							60m6	140	105		1430	325	900	475	61±2	210n6	210	210
15	90m6	165	130							70m6	140	105								1550	365	980	520	72±2	230n6	210	230
16				90m6	165	130							70m6	140	105					1640	365	980	520	72±2	240n6	210	240
17	110m6	205	165							80m6	170	130								1740	395	1110	570	81±2	250n6	230	250
18				110m6	205	165							80m6	170	130					1860	395	1110	570	81±2	270n6	230	275
19	按客户要求供货																										
20	On request																										
21																											
22																											

规格 Size	D3	D4	e3	E	f2	f3	G1	G2	G3	G4	G5	G6	G7	h	l2	m1	m2	n1	n2	P2	s	润滑油Oil (l)	重量 weight (kg)
13	195	190	265	635	35	170	1125	335	1160	335	480	335	1180	272.5	350	1195	680	50	360	500	48	115	2260
14	215	210	265	705	35	170	1195	335	1230	335	480	335	1250	272.5	350	1335	680	50	430	500	48	130	2615
15	235	230	320	762	42	170	1367	380	1402	380	550	380	1420	310	410	1435	750	60	430	570	55	180	3540
16	245	240	320	808	42	170	1413	380	1448	380	550	380	1470	310	410	1525	750	60	475	570	55	190	3765
17	260	250	370	860	42	170	1560	415	1600	415	600	415	1620	340	410	1610	850	70	465	630	55	260	4760
18	285	280	370	920	42	170	1620	415	1660	415	600	415	1680	340	470	1730	850	70	525	630	55	275	5240
19	按客户要求供货																						
20	On request																						
21																							
22																							

齿轮箱
四级传动
立式安装
类型V4.V
规格5-12

Gear Units
Four stage
Vertical
Type V4.V
Sizes 5-12

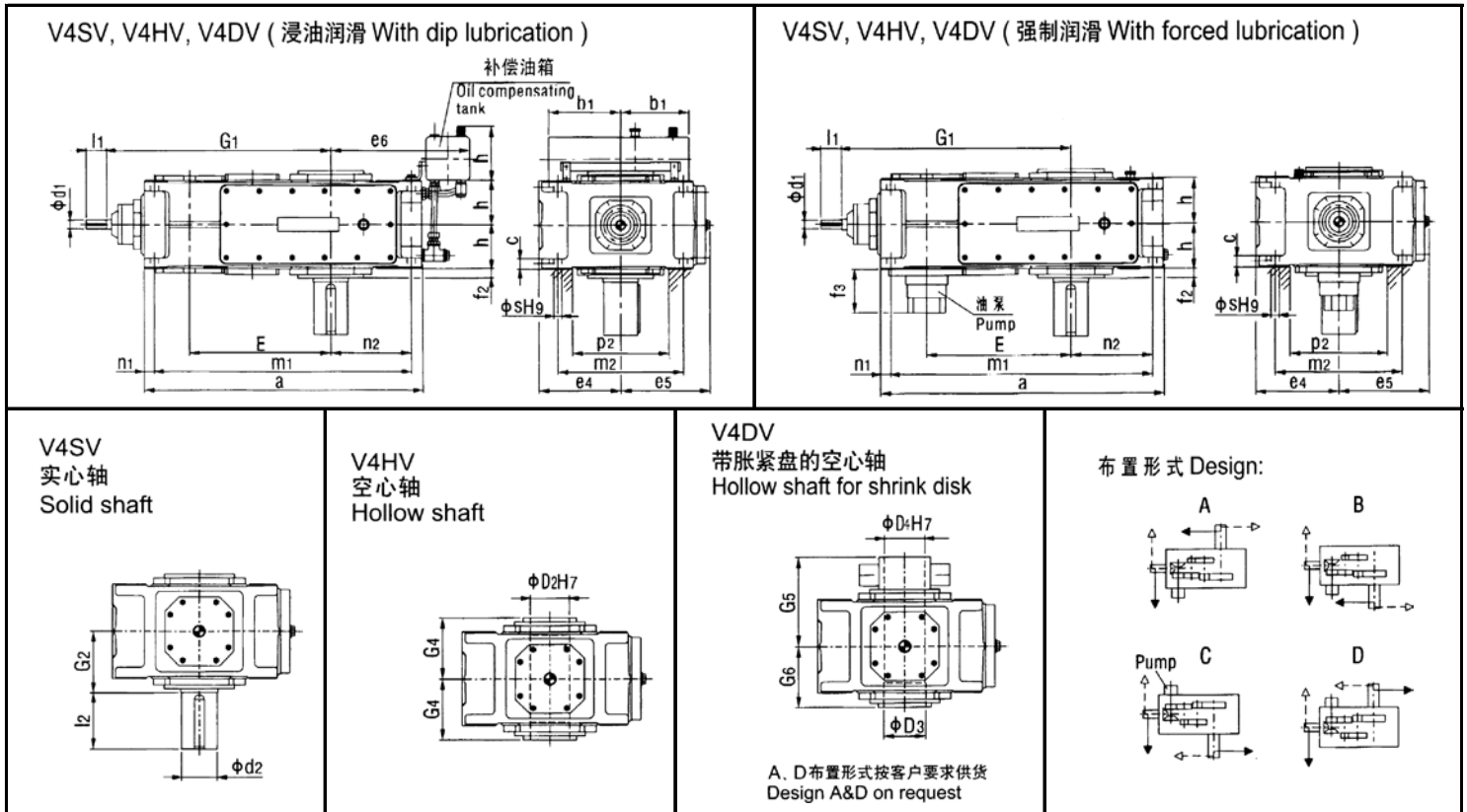

规格 Size	$i_N=80-180$		$i_N=100-224$		$i_N=200-315$		$i_N=250-400$		a	b1	c	d2	D2	D3	D4	e4	e5	e6
	d_1	l_1	d_1	l_1	d_1	l_1	d_1	l_1										
5	28m6	55			20k6	50			690	240	30±1	100m6	95	100	100	230	252	385
6			28m6	55			20k6	50	770	240	30±1	110n6	105	110	110	230	252	425
7	30m6	70			25m6	60			845	240	36±1	120n6	115	120	120	280	292	425
8			30m6	70			25m6	60	950	240	36±1	130n6	125	130	130	280	302	485
9	35m6	80			28m6	60			1000	330	45±1.5	140n6	135	145	140	320	342	560
10			35m6	80			28m6	60	1100	330	45±1.5	160n6	150	155	150	320	342	610
11	45m6	100			35m6	80			1200	330	54±1.5	170n6	165	170	165	380	402	595
12			45m6	100			35m6	80	1353	330	54±1.5	180n6	180	185	180	380	410	680

规格 Size	E	G1	f2	f3	G2	G4	G5	G6	h	h1	l2	m1	m2	n1	n2	P2	s	润滑油oil (l)		重量 weight (kg)
																		(1)**	(2)**	
5	405	615	28	200	165	165	240	165	127.5	205	210	630	360	30	175	270	19	36	18	335
6	440	650	28	200	165	165	240	165	127.5	205	210	710	360	30	220	270	19	40	20	385
7	495	725	30	120	195	195	280	195	150	205	210	775	430	35	215	330	24	65	32	555
8	540	770	32	120	195	195	285	195	150	205	250	880	430	35	275	330	24	73	36	655
9	580	840	32	120	235	235	330	235	185	275	250	920	490	40	260	370	28	115	65	890
10	630	890	32	120	235	235	350	235	185	275	300	1020	490	40	310	370	28	140	75	1025
11	705	1010	35	130	270	270	400	270	215	275	300	1100	600	50	295	440	35	190	85	1485
12	775	1080	35	130	270	270	405	270	215	275	300	1255	600	50	380	440	35	200	100	1750

(1)** 浸油润滑; (2)** 强制润滑

(1)** Dip lubrication, (2)** Forced lubrication

齿轮箱
四级传动
立式安装
类型 V4.V
规格 13-22

Gear Units
Four stage
Vertical
Type V4.V
Sizes 13-22

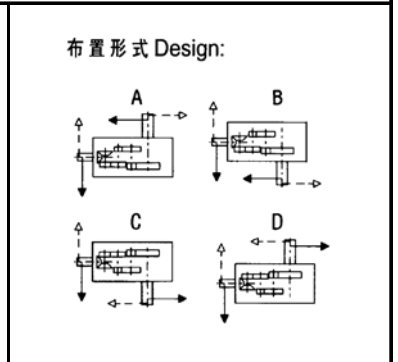
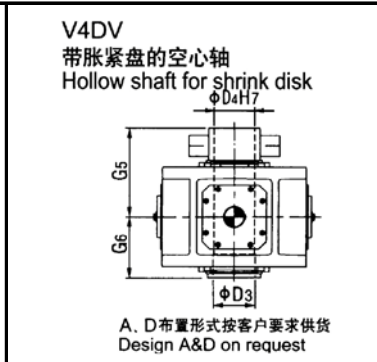
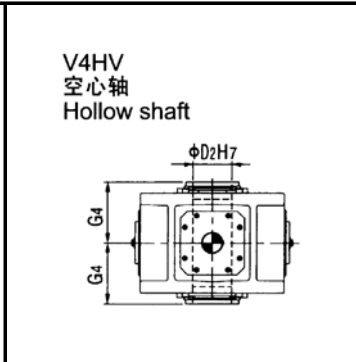
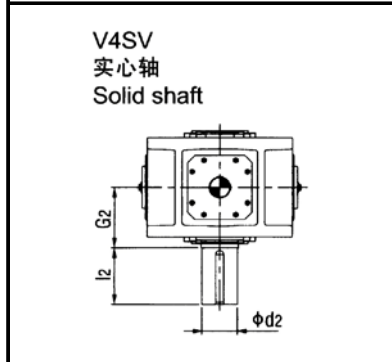
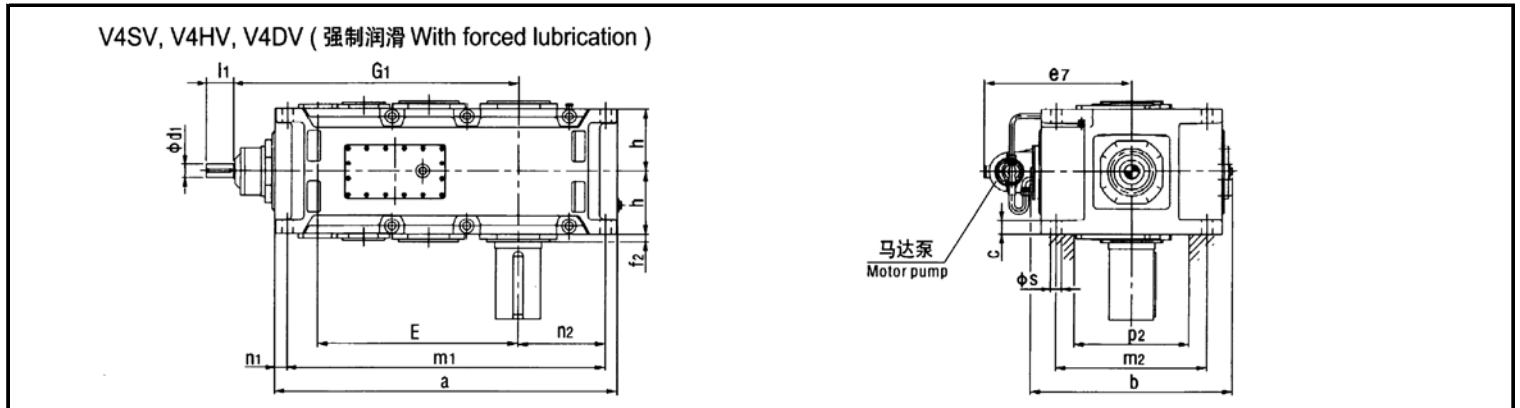

规格 Size	$i_N=80-180$		$i_N=90-200$		$i_N=100-224$		$i_N=200-315$		$i_N=224-355$		$i_N=250-400$		a	b	c	d2	D2	D3
	d_1	l_1	d_1	l_1	d_1	l_1	d_1	l_1	d_1	l_1	d_1	l_1						
13	55m6	110					40m6	100					1395	900	61 ± 2	200n6	190	195
14					55m6	110					40m6	100	1535	900	61 ± 2	210n6	210	215
15	70m6	135					50m6	110					1680	980	72 ± 2	230n6	230	235
16			70m6	135					50m6	110			1770	980	72 ± 2	240n6	240	245
17	70m6	135					50m6	110					1770	1110	82 ± 2	250n6	270	260
18			70m6	135					50m6	110			1890	1110	82 ± 2	270n6	275	285
19	按客户要求供货																	
20	On request																	
21	On request																	
22	On request																	

规格 Size	D_4	e_7	E	f_2	G_1	G_2	G_4	G_5	G_6	h	l_2	m_1	m_2	n_1	n_2	P_2	s	润滑油	重量
																		Oil (l)	Weight (kg)
13	190	690	820	35	1170	335	335	480	335	273	350	1300	680	50	360	500	48	135	2280
14	210	690	890	35	1240	335	335	480	335	273	350	1440	680	50	430	500	48	150	2605
15	230	730	987	42	1402	380	380	550	380	310	410	1565	750	60	430	570	55	210	3435
16	240	730	1033	42	1448	380	380	550	380	310	410	1655	750	60	475	570	55	240	3765
17	250	790	1035	42	1450	415	415	600	415	340	410	1640	850	70	465	630	55	270	4460
18	280	790	1095	42	1510	415	415	600	415	340	470	1760	850	70	525	630	55	285	4930
19	按客户要求供货																		
20	On request																		
21	On request																		
22	On request																		

齿轮箱冷却盘管尺寸图 卧式安装

Gear Unit Cooling coils Horizontal

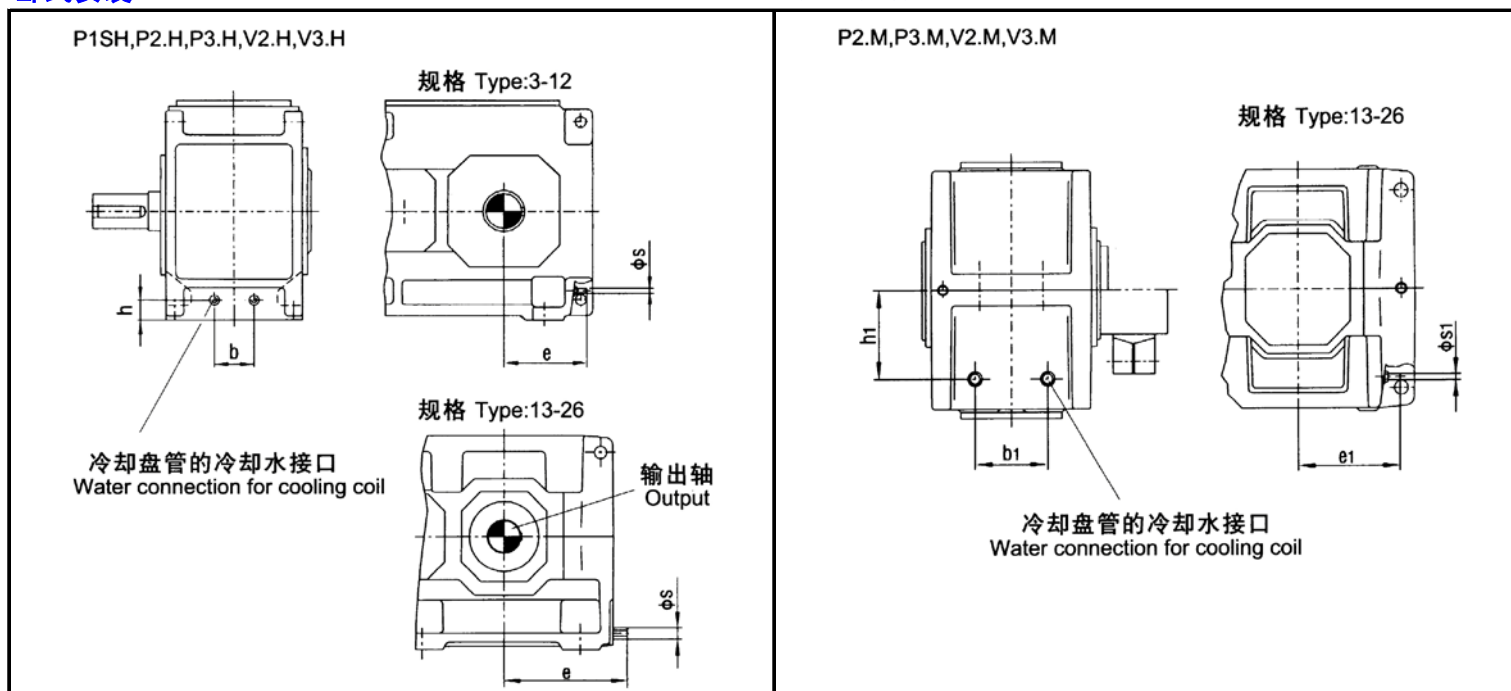

规格 Size	P1SH					P2H/V3.H					P3.H					V2.H					
	b	e	h	s	水量 water quantity (l)	b	e	h	s	水量 water quantity (l)	b	e	h	s	水量 water quantity (l)	b	e	h	s	水量 water quantity (l)	
3	48	205	74	G1/2	4	-	-	-	-	-	-	-	-	-	-	-	-	-	-	-	-
4	-	-	-	-	-	34	155	60	G1/2	4	-	-	-	-	-	74	160	54	G1/2	4	-
5	88	270	90	G1/2	4	68	170	64	G1/2	4	70	175	60	G1/2	4	130	175	62	G1/2	8	-
6	-	-	-	-	-	70	215	68	G1/2	4	70	220	69	G1/2	4	120	220	68	G1/2	4	-
7	124	310	135	G1/2	4	100	210	83	G1/2	4	80	210	83	G1/2	4	140	210	80	G1/2	8	-
8	-	-	-	-	-	100	270	83	G1/2	4	80	270	83	G1/2	4	140	270	80	G1/2	4	-
9	116	365	110	G1/2	8	140	245	110	G1/2	8	150	245	107	G1/2	4	232	245	110	G1/2	8	-
10	-	-	-	-	-	100	295	95	G1/2	8	90	295	95	G1/2	4	150	295	90	G1/2	8	-
11	146	425	130	G1/2	8	110	275	95	G1/2	8	200	275	115	G1/2	8	312	275	115	G1/2	8	-
12	-	-	-	-	-	200	360	109	G1/2	8	200	360	115	G1/2	8	300	360	115	G1/2	8	-
13	152	480	150	G1/2	8	252	455	116	G1/2	8	252	460	116	G1/2	8	324	460	116	G1/2	8	-
14	-	-	-	-	-	252	525	116	G1/2	8	252	530	116	G1/2	8	324	530	116	G1/2	8	-
15	172	560	130	G1/2	8	290	535	119	G1/2	8	290	540	119	G1/2	8	396	540	119	G1/2	8	-
16	-	-	-	-	-	290	580	119	G1/2	8	290	585	119	G1/2	8	396	585	119	G1/2	8	-
17	202	600	145	G1/2	8	340	575	134	G1/2	8	300	580	134	G1/2	8	468	580	134	G1/2	8	-
18	-	-	-	-	-	340	635	134	G1/2	8	300	640	134	G1/2	8	468	640	134	G1/2	8	-
19	按客户要求供货 On request					按客户要求供货 On request					按客户要求供货 On request										
20-26	-																				

规格 Size	P2.M/V3.M					P3.M				V2.M					
	b1	e1	h1	s1	水量	b1	e1	h1	s1	水量	b1	e1	h1	s1	水量
					water					water					
					quantiy					quantiy					
(l)	(l)														
13	252	335	300	G1/2	8	252	335	300	G1/2	8	324	335	300	G1/2	8
14	252	405	300	G1/2	8	252	405	300	G1/2	8	324	405	300	G1/2	8
15	290	395	335	G1/2	8	290	395	340	G1/2	8	396	390	345	G1/2	8
16	290	440	335	G1/2	8	290	440	340	G1/2	8	396	435	345	G1/2	8
17	340	425	380	G1/2	8	300	425	380	G1/2	8	324	425	395	G1/2	8
18	340	485	380	G1/2	8	300	485	380	G1/2	8	324	485	953	G1/2	8
19-26	按客户要求供货 On request					按客户要求供货 On request				-					

注：冷却盘管适应于淡水、海水和半咸水。

Note: Cooling Coil suitable for fresh, sea and brackish water

齿轮箱冷却盘管尺寸图
立式安装

Gear units cooling coils
vertical

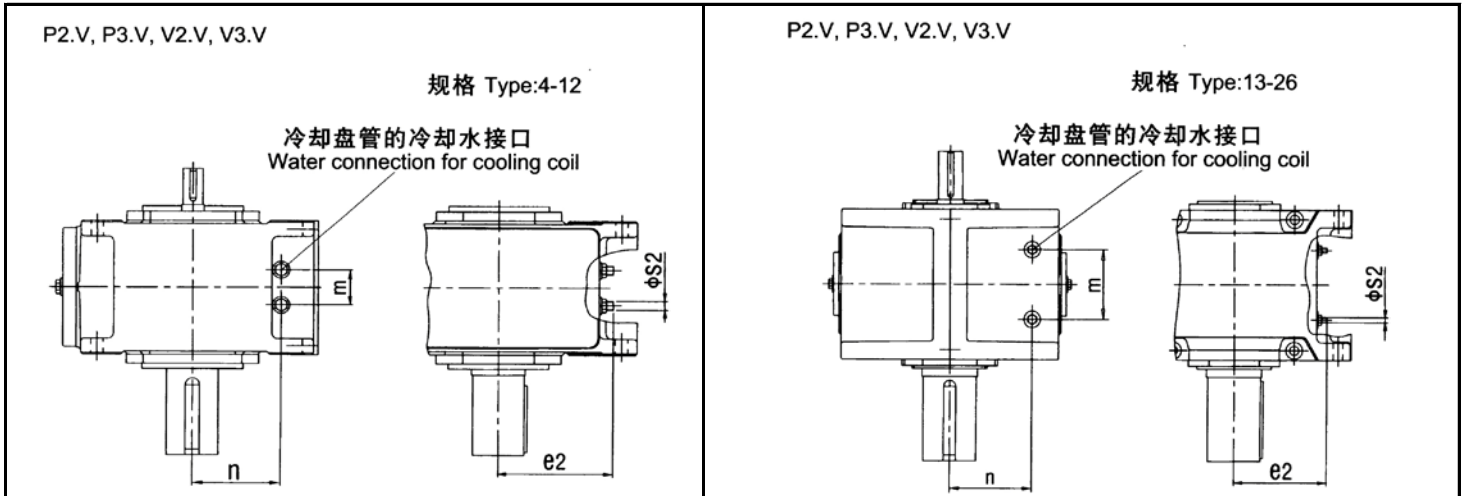

规格	P2.V/ V3.V					P3.V					V2.V				
size	m	n	e2	s2	水量water(l)	m	n	e2	s2	水量water(l)	m	n	e2	s2	水量water(l)
4	34	140	155	G1/2	4	—	—	—	—	—	74	146	160	G1/2	4
5	68	166	170	G1/2	4	70	170	175	G1/2	4	130	168	175	G1/2	8
6	70	162	215	G1/2	4	70	161	220	G1/2	4	120	162	220	G1/2	4
7	100	197	210	G1/2	4	80	197	210	G1/2	4	140	200	210	G1/2	8
8	100	197	270	G1/2	4	80	197	270	G1/2	4	140	200	270	G1/2	4
9	140	210	245	G1/2	8	150	213	245	G1/2	4	232	210	245	G1/2	8
10	100	225	295	G1/2	8	90	225	295	G1/2	4	150	230	295	G1/2	8
11	110	285	275	G1/2	8	200	265	275	G1/2	8	312	265	275	G1/2	8
12	200	271	360	G1/2	8	200	265	360	G1/2	8	300	265	360	G1/2	8
13	252	300	335	G1/2	8	252	265	335	G1/2	8	324	300	335	G1/2	8
14	252	300	405	G1/2	8	252	300	405	G1/2	8	324	300	405	G1/2	8
15	290	335	395	G1/2	8	290	300	395	G1/2	8	396	345	390	G1/2	8
16	290	335	440	G1/2	8	290	340	440	G1/2	8	396	345	435	G1/2	8
17	340	380	425	G1/2	8	300	380	425	G1/2	8	324	395	425	G1/2	8
18	340	380	485	G1/2	8	300	380	485	G1/2	8	324	395	485	G1/2	8

19-26 按客户要求供货 On request

按客户要求供货 On request

类型 Type	规格 Size	冷却盘管适用于cooling coil for											
		浸油润滑dip lurication				法兰泵强制润滑Forced lubrication with flanged-on pump				电动泵强制润滑Forced lubrication with motor pump			
		适用布置形式For design				适用布置形式 For design				适用布置形式 For design			
		A	B	C	D	A	B	C	D	A	B	C	D
P2.V	4	√	√	√	√	—	—	—	—	按客户要求供货 On request			
	5-12	√	√	√	√	—	√	—	√				
	13-18	—	—	—	—	—	√	—	√				
P3.V	5-12	√	√	√	√	—	√	—	√				
	13-18	—	—	—	—	—	√	—	√				
V2.V	4	√	√	√	√	—	—	—	—				
	5-12	√	√	√	√	√	√	—	—				
	13-18	—	—	—	—	√	√	—	—				
V3.V	4	√	√	√	√	—	—	—	—				
	5-12	√	√	√	√	—	—	√	√				
	13-18	—	—	—	—	—	—	√	√				

注: 冷却盘管适用于淡水,海水和半咸水.

Note: Cooling coil suitable for fresh, sea and brackish water.

齿轮箱
带锁紧盘的空心轴

类型V2
规格4-18

Gear units
Hollow shafts for
Shrink Disks
Type V2
Size 4-18

X = 要求预留的力矩扳手空间
X = Space required for torque wrench

用于缩紧盘联接的工作机驱动轴。
工作机驱动轴表面不得沾有机油或润滑脂。
Driven machine shaft for shrink disk connection. Driven
machine shaft must be free of oil or grease.

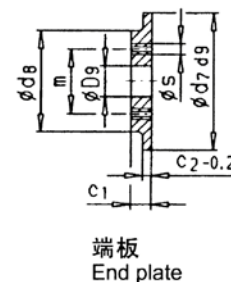
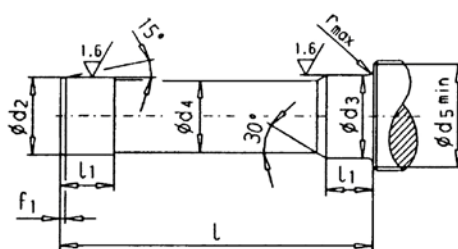
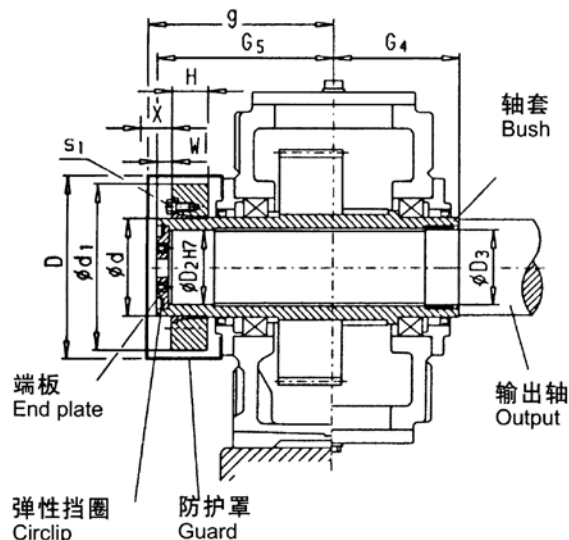

类型 / TypeV2D

齿轮箱规格 Gear unit size	工作机驱动轴2) Driven machine shaft								端板 End plate								弹性挡圈 ring circlip	空心轴 Hollow shaft					锁紧盘 Shrink disk 1)				螺钉 Screw	防护罩 Guard	
	d2	d3	d4	d5	f1	l	l1	r	c1	c2	d7	d8	D9	m	s	数量 Qty.	DIN	D2	D3	G4	G5	类型 type	d	d1	H	W	s1	D	g
									mm																				
4	85 g6	85 h6	84.5	95	4	386	48	2	17	7	90	70	22	50	M8	2	90X3	85	85	170	235	110-32	110	185	49	20	M12	235	250
5	100 g6	100 h6	99.5	114	5	453	53	2	20	8	105	80	26	55	M10	2	105X4	100	100	200	275	125-32	125	215	53	20	M12	275	285
6	110 g6	110 h6	110	124	5	453	58	3	20	8	115	85	26	60	M10	2	115X4	110	110	200	275	140-32	140	230	58	20	M14	285	285
7	120 g6	120 h6	120	134	5	533	68	3	20	8	125	90	26	65	M12	2	125X4	120	120	235	320	155-32	155	263	62	23	M14	330	335
8	130 g6	130 h6	130	145	6	538	73	3	20	8	135	100	26	70	M12	2	135X4	130	130	235	325	165-32	165	290	68	23	M16	340	340
9	140 g6	145 m6	140	160	6	609	82	4	23	10	150	110	33	80	M12	2	150X4	140	145	270	365	175-32	175	300	68	28	M16	360	380
10	150 g6	155 m6	150	170	6	629	92	4	23	10	160	120	33	90	M12	2	160X4	150	155	270	385	200-32	200	340	85	28	M16	395	400
11	165 g6	170 m6	165	185	7	744	112	4	23	10	175	130	33	90	M12	2	175X4	165	170	320	450	220-32	220	370	103	30	M20	435	470
12	180 g6	185 m6	180	200	7	749	122	4	23	10	190	140	33	100	M16	2	190X4	180	185	320	455	240-32	240	405	107	30	M20	450	470
14	210 g6	215 m6	210	233	8	894	147	5	28	14	220	170	33	130	M16	2	220X5	210	215	390	535	280-32	280	460	132	30	M20	525	555
16	240 g6	245 m6	240	263	8	1039	157	5	28	14	250	190	39	150	M20	2	250X5	240	245	450	620	320-32	320	520	140	35	M24	595	645
18	280 g6	285 m6	280	306	9	1177	177	5	30	14	290	210	39	160	M20	2	290X5	280	285	510	700	360-32	360	590	162	35	M24	635	725

齿轮箱
带锁紧盘的空心轴

类型 P2, P3, P4, V3, V4
规格 4-26

Gear units
Hollow shafts for
Shrink Disks
Types P2, P3, P4, V3, V4
Size 4-26

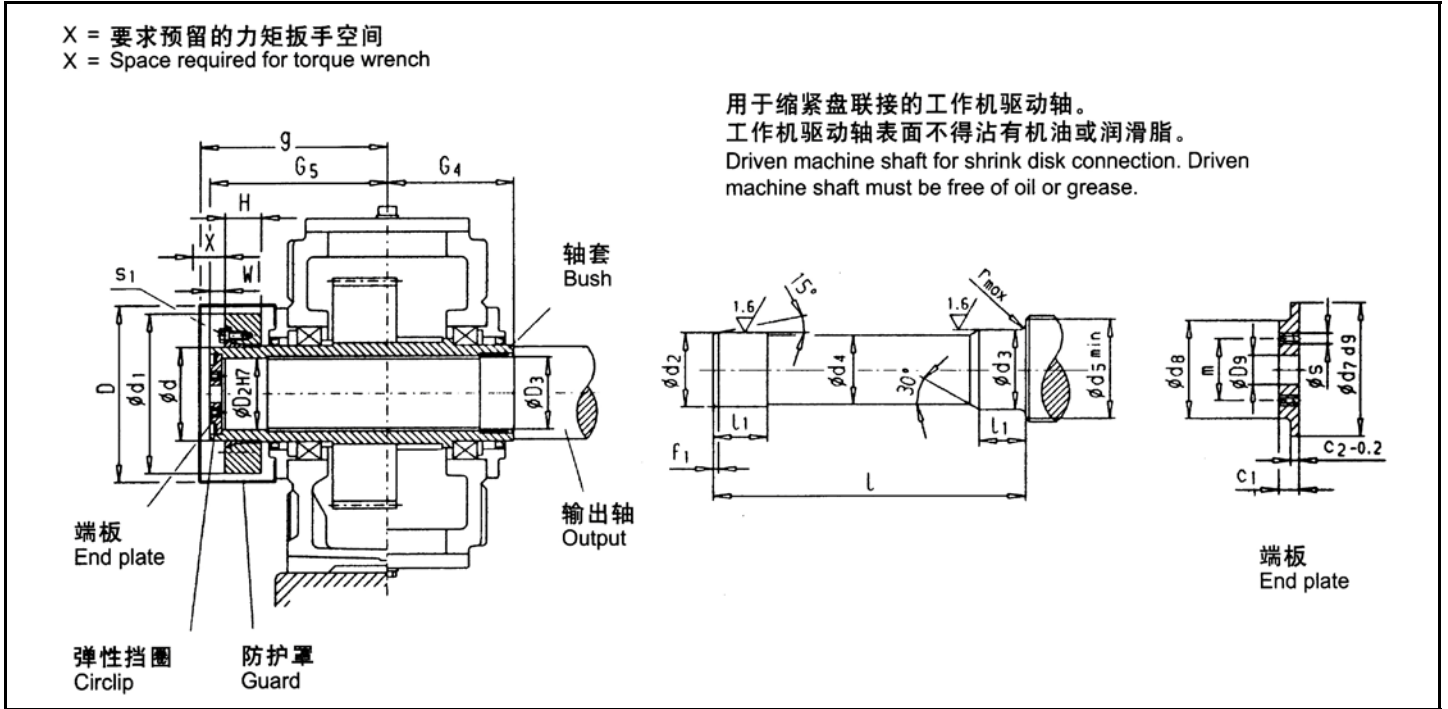

类型 / Type P2D., P3D., P4D., V3D., V4D																																
齿轮箱规格 Gear unit size	工作机驱动轴2) Driven machine shaft															端板 End plate					弹性挡圈 circlip	空心轴 Hollow shaft				锁紧盘 Shrink disk 1)				螺钉 Screw	防护罩 Guard	
	d2	d3	d4	d5	f1	l	l1	r	c1	c2	d7	d8	D9	m	s	数量 Qty	DIN	D2	D3	G4	G5	类型 typ	d	d1	H	W	s1	D	g			
	mm																427	mm														
4	85 g6	85 h6	84.5	95	4	326	48	2	17	7	90	70	22	50	M8	2	90X3	85	85	140	205	110-32	110	185	49	20	M12	235	220			
5	100 g6	100 h6	99.5	114	5	383	53	2	20	8	105	80	26	55	M10	2	105X4	100	100	165	240	125-32	125	215	53	20	M12	275	255			
6	110 g6	110 h6	109.5	124	5	383	58	3	20	8	115	85	26	60	M10	2	115X4	110	110	165	240	140-32	140	230	58	20	M14	285	255			
7	120 g6	120 h6	119.5	134	5	453	68	3	20	8	125	90	26	65	M12	2	125X4	120	120	195	280	155-32	155	263	62	23	M14	330	295			
8	130 g6	130 h6	129.5	145	6	458	73	3	20	8	135	100	26	70	M12	2	135X4	130	130	195	285	165-32	165	290	68	23	M16	340	300			
9	140 g6	145 m6	139.5	160	6	539	82	4	23	10	150	110	33	80	M12	2	150X4	140	145	235	330	175-32	175	300	68	28	M16	360	345			
10	150 g6	155 m6	149.5	170	6	559	92	4	23	10	160	120	33	90	M12	2	160X4	150	155	235	350	200-32	200	340	85	28	M16	395	365			
11	165 f6	170 m6	164.5	185	7	644	112	4	23	10	175	130	33	90	M12	2	175X4	165	170	270	400	220-32	220	370	103	30	M20	435	420			
12	180 f6	185 m6	179.5	200	7	649	122	4	23	10	190	140	33	100	M16	2	190X4	180	185	270	405	240-32	240	405	107	30	M20	450	420			
13	190 f6	195 m6	189.5	213	7	789	137	5	23	10	200	150	33	110	M16	2	200X4	190	195	335	480	260-32	260	430	119	30	M20	500	505			
14	210 f6	215 m6	209.5	233	8	784	147	5	28	14	220	170	33	130	M16	2	220X5	210	215	335	480	280-32	280	460	132	30	M20	525	505			
15	230 f6	235 m6	229.5	253	8	899	157	5	28	14	240	180	39	140	M16	2	240X5	230	235	380	550	300-32	300	485	140	35	M24	575	575			
16	240 f6	245 m6	239.5	263	8	899	157	5	28	14	250	190	39	150	M20	2	250X5	240	245	380	550	320-32	320	520	140	35	M24	595	575			
17	250 f6	260 m6	249.5	278	8	982	177	5	30	14	265	200	39	150	M20	2	265X5	250	260	415	600	340-32	340	570	155	35	M24	615	630			
18	280 f6	285 m6	279.5	306	9	982	177	5	30	14	290	210	39	160	M20	2	290X5	280	285	415	600	360-32	360	590	162	35	M24	635	625			
19	285 f6	295 m6	284.5	316	9	###	187	5	32	15	300	220	39	170	M24	2	300X5	285	195	465	670	380-32	380	640	166	40	M27	-	-			
20	310 f6	315 m6	309.5	336	9	###	187	5	32	15	320	230	39	180	M24	2	320X6	310	315	465	670	390-32	390	650	166	40	M27	-	-			
21	330 f6	335 m6	329	358	9	###	205	5	40	20	340	250	45	190	M24	2	340X6	330	335	490	715	420-32	420	670	186	45	M27	-	-			
22	340 f6	345 m6	339	368	9	###	215	5	40	20	350	260	45	200	M24	2	350X6	340	345	490	725	440-32	440	720	194	45	M27	-	-			
23-26	敬请垂询/On request																															

齿轮箱

Gear Units

带平键联接的空心轴

Hollow Shafts for Parallel
Key Connections

类型 V2

Types V2

规格 4-18

Size 4-18

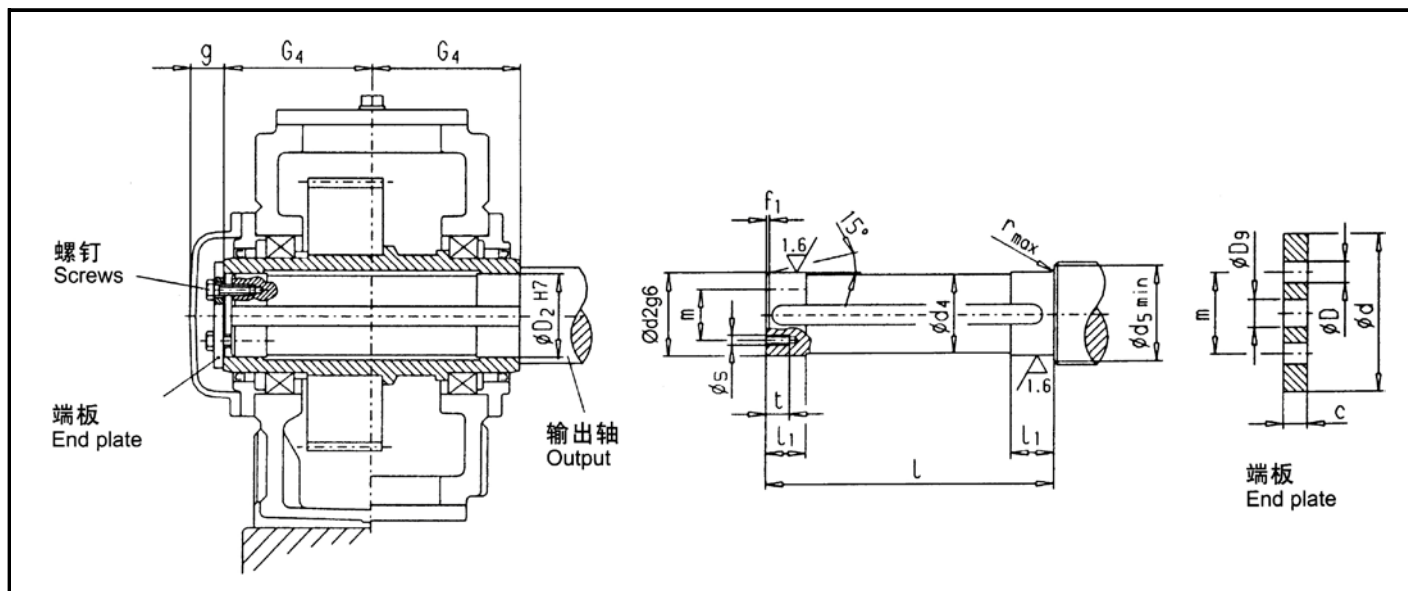

类型/Types V2H.

齿轮箱 规格 Gear unit size	工作机驱动轴 ¹⁾ Driven machine shaft									端板 End plate					螺钉 Screw		空心轴 Hollow shaft		
	d_2	d_4	d_5	f_1	l	l_1	r	s	t	c	D	D_9	d	m	规格 Size	数量 Qty	D_2	G_4	g
	mm																		
4	80	79.5	88	4	338	35	1.2	M10	18	10	11	22	100	60	M10×25	2	80	170	35
5	95	94.5	105	5	398	40	1.6	M10	18	10	11	26	120	70	M10×25	2	95	200	40
6	105	104.5	116	5	398	45	1.6	M10	18	10	11	26	120	70	M10×25	2	105	200	40
7	115	114.5	126	5	468	50	1.6	M12	20	12	13.5	26	140	80	M12×30	2	115	235	40
8	125	124.5	136	6	468	55	2.5	M12	20	12	13.5	26	150	85	M12×30	2	125	235	40
9	135	134.5	147	6	537	60	2.5	M12	20	12	13.5	33	160	90	M12×30	2	135	270	45
10	150	149.5	162	6	537	65	2.5	M12	20	12	13.5	33	185	110	M12×30	2	150	270	45
11	165	164.5	177	7	637	70	2.5	M16	28	15	17.5	33	195	120	M16×40	2	165	320	45
12	180	179.5	192	7	637	75	2.5	M16	28	15	17.5	33	220	130	M16×40	2	180	320	45
14	210	209.5	226	8	777	85	3	M16	28	18	17.5	33	250	160	M16×40	2	210	390	45
16	240	239.5	258	8	896	100	3	M20	38	25	22	39	280	180	M20×55	4	240	450	60
18	275	274.5	295	9	1016	120	4	M20	38	25	22	39	330	210	M20×55	4	275	510	60

齿轮箱

Gear Units

带平键联接的空心轴

Hollow Shafts for Parallel Key Connections

类型 P2, P3, P4, V3, V4

Types P2, P3, P4, V3, V4

规格 4-18

Size 4-18

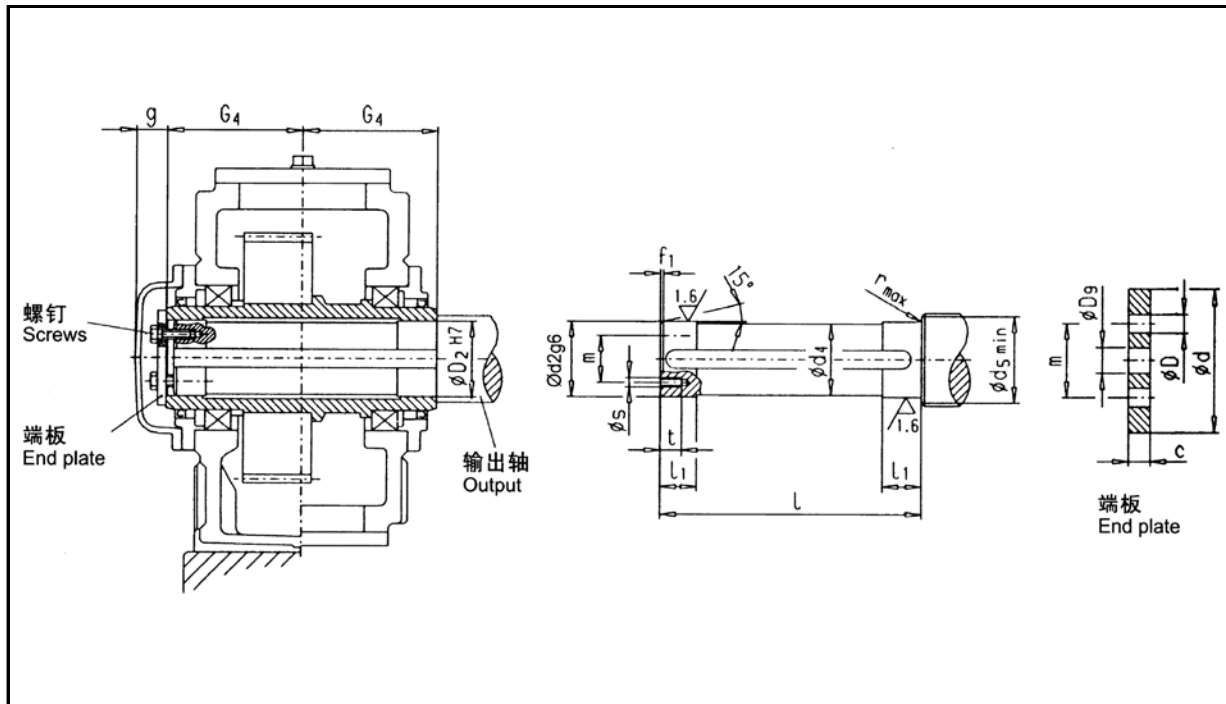

类型/Types P2H.,P3H.,P4H.,V3H.,V4H.																			
齿轮箱规格 Gear unit size	工作机驱动轴 ¹⁾ Driven machine shaft									端板 End plate				螺钉 Screw		空心轴 Hollow shaft			
	d_2	d_4	d_5	f_1	l	l_1	r	s	t	c	D	D_9	d	m	规格 Size	数量 Qty	D_2	G_4	g
	mm																		
4	80	79.5	88	4	278	35	1.2	M10	18	10	11	22	100	60	M10×25	2	80	140	35
5	95	94.5	105	5	328	40	1.6	M10	18	10	11	26	120	70	M10×25	2	95	165	40
6	105	104.5	116	5	328	45	1.6	M10	18	10	11	26	120	70	M10×25	2	105	165	40
7	115	114.5	126	5	388	50	1.6	M12	20	12	13.5	26	140	80	M12×30	2	115	195	40
8	125	124.5	136	6	388	55	2.5	M12	20	12	13.5	26	150	85	M12×30	2	125	195	40
9	135	134.5	147	6	467	60	2.5	M12	20	12	13.5	33	160	90	M12×30	2	135	235	45
10	150	149.5	162	6	467	65	2.5	M12	20	12	13.5	33	185	110	M12×30	2	150	235	45
11	165	164.5	177	7	537	70	2.5	M16	28	15	17.5	33	195	120	M16×40	2	165	270	45
12	180	179.5	192	7	537	75	2.5	M16	28	15	17.5	33	220	130	M16×40	2	180	270	45
13	190	189.5	206	7	667	80	3	M16	28	18	17.5	33	230	140	M16×40	2	190	335	45
14	210	209.5	226	8	667	85	3	M16	28	18	17.5	33	250	160	M16×40	2	210	335	45
15	230	229.5	248	8	756	100	3	M20	38	25	22	39	270	180	M20×55	4	230	380	60
16	240	239.5	258	8	756	100	3	M20	38	25	22	39	280	180	M20×55	4	240	380	60
17	250	249.5	270	8	826	110	4	M20	38	25	22	39	300	190	M20×55	4	250	415	60
18	275	274.5	295	9	826	120	4	M20	38	25	22	39	330	210	M20×55	4	275	415	60



山东国茂国泰减速机有限公司

SHANDONG GUOMAOGUOTAI REDUCER CO., LTD.

地址：中国山东省烟台市芝罘区只楚路 55-1 号

Add: No. 55-1, Zhichu Road, Zhifu District, Yantai City, Shandong Province, China

电话 (Tel): 0086-535-6513033 6527155

传真 (Fax): 0086-535-6527055

外贸部 (International trade department): 0086-535-6511737

邮箱 (E-mail): sdguomao@yahoo.com.cn

网址 (Website): [Http://www.cnspeedreducer.com](http://www.cnspeedreducer.com)

邮编 (Post code): 264000